

04/2024

Outdoor Living ► Roof systems

Roof systems

Technical data

Der SonnenLichtManager





Technical data Valid from 01.04.2024

The publication of this document supersedes all previous corresponding documents. Our general terms and conditions (GTC) can be viewed and downloaded on our homepage at www.warema.de/agb.

We will gladly provide our information in printed form. Please note that in the event of updates, the online version is binding. Particular care was taken in producing the text and graphics in this documentation. In spite of this, we cannot accept liability for any existing (printing) errors, mistakes or the consequences thereof. Changes and deviations from the technical specifications and product presentations are possible as a result of the individual structural conditions.

Our products are individual or made-to-measure items and therefore cannot be exchanged or returned.

Safety instructions

For detailed information please see the Tech-Data or the installation and operating instructions.

© Copyright 2024 / Copyright notice

All contents of this publication, particularly texts, photographs and graphics, are protected by copyright. Unless expressly stated otherwise, the copyright is held by WAREMA. All rights, including reproduction, publication, editing and translation remain reserved.

WAREMA and the WAREMA logo are trademarks of WAREMA Renkhoff SE. Other logos used here are brands or trademarks of their respective owners.

Legal details

WAREMA International GmbH
Hans-Wilhelm-Renkhoff-Straße 2
97828 Marktheidenfeld
Germany

Contents

Interesting facts about planning.....	9
Colours and finishes.....	10
General information.....	12
Slat roofs Lamaxa.....	25
Slat roofs Lamaxa L70.....	26
Slat roofs Lamaxa L70 Line.....	42
Slat roofs Lamaxa L60.....	56
Slat roofs Lamaxa L60 Line.....	74
Slat roofs Lamaxa L50.....	88
Slat roofs Lamaxa L50 Line.....	100
Glass roofs Lamaxa.....	113
Glass roofs Lamaxa L50 View.....	114
Fabric roofs Lamaxa.....	131
Fabric roofs Lamaxa L50 Tex.....	132
Supplementary accessories.....	143
Design radiant heater.....	144
Lamaxa lighting.....	148
Shading systems.....	154
Sash frames.....	172
Additional pole.....	186
Offset pole.....	192
Power socket.....	196
Protection profile.....	198
Drive variants.....	201
Motor.....	202
Manual operation.....	205
Standards.....	207

Planning

Slat roofs
Lamaxa

Glass roofs
Lamaxa

Fabric roofs
Lamaxa

Supplementary
accessories

Drive
variants

Standards

Navigating the document



Ordering from WAREMA

In this document you will find for each product a link to the relevant **Order form**. Open the link or copy it into your browser. Alternatively, you can order directly via **myWAREMA** by opening the link or entering the article number after logging in. Please make sure to register as a customer first.

Drawings

Download your desired drawings: in the digital version of this document, start the download by clicking on the PDF or DWG symbol.

WAREMA tools

Sun Shading Planner

Use our free planning programme to plan your sun protection systems

<https://sonnenschutzplaner.de>

Collection Assistant

Experience the range of colours and fabrics of the WAREMA collections

<https://www.warema.de/Tools/Kollektionsberater.php>

Fastener Assistant

Calculate the individual suitable and permissible fixing materials

<https://www.warema.com/fastener-assistant>

Console Planner

Calculate the exact position of the console, tensile force and wind resistance class

<https://konsolenplaner.warema.de/v2/>

Dimensions Assistant

Conveniently and easily determine the slat stack height

<https://my.warema.com/v2/dimensionAssistant?page=0>

More TechData

External venetian blinds

<https://sls.warema.com/514644ENINT>

Roller shutters

<https://sls.warema.com/514648ENINT>

Window awnings

<https://sls.warema.com/514654ENINT>

Insect and pollen protection

<https://sls.warema.com/513039ENINT>

Railing systems VisioNeo for windows

<https://sls.warema.com/959906ENINT>

Patio awnings

<https://sls.warema.com/514652ENINT>

Roof systems

<https://sls.warema.com/755716ENINT>

Sun sails Sonea

<https://sls.warema.com/767443ENINT>

Black-out blinds

<https://sls.warema.com/513502ENINT>

Control systems

<https://sls.warema.com/514746ENINT>



WAREMA Update

Roof systems

News and Highlights

The new Lamaxa L60 and L70

Latest update to the premium slat roof L60 and L70

Our Lamaxa slat roofs have been continuously developed for many years in terms of quality, aesthetics, technology and comfort. Easier to assemble than ever before and featuring a simpler design, the new Lamaxa L60 and L70 offer more convenience and improved handling.

+ see "Slat roofs Lamaxa L70", Page 26

+ see "Slat roofs Lamaxa L60", Page 56



WAREMA Colour World 2024

Over the course of 2024, we will be updating the WAREMA Colour World to account for the latest market trends and customer demands. There are plenty of new things to look forward to, including new colours and surface qualities to choose from. Stay tuned - we'll keep you up to date!



+ see "Colours and finishes", Page 10

L60/L70 Free variant

Offset wall console

In order to integrate slat roofs into existing structures as Free variants, they can also be equipped with an offset wall console (Free variant). The offset wall console can be positioned at individual or any mounting points for flexible setup options.

+ see "Slat roofs Lamaxa L70", Page 26

+ see "Slat roofs Lamaxa L60", Page 56



Planning

Slat roofs
Lamaxa

New slats for Lamaxa L50

Small change with a big impact

The slats in the Lamaxa L50 allow the roof to be carefully and quietly closed. The slat geometry has also been optimised. Rainwater runs off the slats.

+ see "Slat roofs Lamaxa L50", Page 88



Glass roofs
Lamaxa

L50 View with increased snow load (available on request)

Starting in the new season, the L50 View is optionally available with an increased snow load of 200 kg/m². A variant capable of handling 400 kg/m² is also available for regions particularly affected by snow.

+ see "Glass roofs Lamaxa L50 View", Page 114



Fabric roofs
Lamaxa

Supplementary
accessories

Drive
variants

Rectangular power socket and drainage

Redesigned

In line with the cubic design, a rectangular outdoor power socket can now be installed on the inside or outside of each post. Drainage is also available in a rectangular form to round off the edgy structural design. An extended rainwater spout can be provided on request.

+ see "Power socket", Page 196



Measurement and Installation Training

The measuring and assembly training courses are now also available for our customers in international markets. With our training sessions, you and your employees will become real experts in the installation of WAREMA slat roofs, pergola awnings and sun sails. Prices and additional information available on request.



5-year manufacturer's warranty

Outdoor living products from WAREMA come with the benefit of an exclusive, free-of-charge manufacturer's guarantee for 5 years. The comprehensive guarantee does not only cover the product itself, but also any accessories and options purchased alongside it. The only thing the consumer needs to do for this added security is to register their product online.

Find out more on our website.



Contents

Interesting facts about planning

Colours and finishes.....	10
WAREMA Colour World for powder-coated aluminium components.....	10
Colour categories.....	10
Finishes.....	11
General information.....	12
Note on the Lamaxa surface quality.....	12
Manufacturing tolerances.....	12
Structural engineering calculation/CE mark.....	13
Planning permission.....	13
Alignment to the sun.....	14
Direction of rotation of the slats.....	14
Slat roof guidelines.....	15
Connection/Connecting line.....	15
Number of channels and dimmers depending on the equipment.....	16
Rain.....	18
Wind.....	19
Beaufort table.....	19
Load bearing capacity.....	20
Snow.....	20
Maximum snow load Lamaxa L60/L70.....	21
Maximum snow load Lamaxa L50.....	21
Roof patios.....	22
Touch-up pens.....	22
Installation lift.....	23
Planning requirements - L50 Line and Star unit.....	23
Sealing.....	24

Planning

Slat roofs
Lamaxa

Glass roofs
Lamaxa

Fabric roofs
Lamaxa

Supplementary
accessories

Drive
variants

Standards



Interesting facts about planning Colours and finishes

WAREMA Colour World for powder-coated aluminium components

Choose the perfect shade from a wide range of attractive powder colours for your powder-coated aluminium profiles such as guide rails, guide profiles, cover panels, boxes and frames.

The current WAREMA Colour World for powder-coated aluminium components and all available colour charts can be found on our homepage.

Colour categories

The variety and composition of the WAREMA Colour World are constantly updated to reflect the latest market trends and customer demands. The classification into categories helps you to find the right colour for your individual sun shading system.

Highlight

This category contains hand-picked standard colours that reflect the latest market demands and colour trends. With the collections and colour charts for external venetian blind slats, roller shutter curtains and fabrics, the colour shades unite to form the perfect unit.

Variation

Over 50 additional RAL basic colours complement the existing Highlight category.

Individual

For even more individuality and colour diversity, over 100 more colours complete the WAREMA Colour World.

Special version

Not found what you're looking for in the WAREMA Colour World? On request, colours not included in the WAREMA Colour World are also available.



Finishes

The WAREMA Colour World doesn't just offer a wide range of options in terms of colour variety, it also offers a vast array of surface structures and gloss levels. Thanks to the individual characteristics of the WAREMA Colour World, you can perfectly adapt your powder-coated aluminium components to the structural conditions at hand.

The outstanding quality of the coating guarantees long-term satisfaction with our products. This has been independently tested by the German Quality Association for the Coating of Building Materials (GSB). The surface coating with a chrome-free pretreatment complies with the GSB AL 631 directive.

The aluminium parts are delivered in "GSB Sea-Proof" as standard.



Satin finish

Satin finish is a slightly glossy surface with a smooth finish and optimal light and weather resistance.



Matt

A matt surface is distinguished by its smooth matt finish and optimal light and weather resistance.

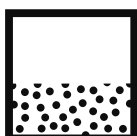

Fine texture

The fine texture has impressive effects, as characterised by the optimal light and weather resistance of the surface.

Highly weather-resistant powder coating



Highly weather-resistant

The highly weather-resistant finish is particularly suited to all severe weather conditions. It is colour-fast, has a long-lasting uniform finish, does not chalk and is extremely weather-proof. This kind of coating is only available in combination with matt surface structures.

Not able to find the right surface quality? On request, surface qualities not included in the WAREMA standard range are also available.

Stay up to date!

The current WAREMA Colour World for powder-coated aluminium components can be found on our homepage or myWAREMA.

Special version

Alternatively, WAREMA offers anodised finishes for numerous extruded aluminium parts.

- natural colours anodised
 - C0
- anodised in colour
 - C31 Light bronze
 - C32 Pale bronze
 - C33 Medium bronze
 - C34 Dark bronze
 - C35 Black

The anodised shades are shown in the anodisation colour chart.



Interesting facts about planning

General information

Note on the Lamaxa surface quality

The fine texture surface quality is the most common and suitable for this type of product variant and ensures a uniform surface appearance. It is more resistant and less sensitive to external influences such as dirt, marks and scratches. A highly weather-resistant surface in fine texture is characterised by an improved weathering behaviour with regard to gloss retention, weathering, chalking and colour stability.

The slat colour and the frame colour (poles, crossbeams, equalisation plates) can be selected independently of one another. A light slat colour can prevent the room beneath the slat roof from heating up too much.

Manufacturing tolerances

Each product is manufactured precisely to customer requirements. Please note that small production-related deviations can occur.

Manufacturing tolerances

Order width in mm	T in mm	Order length in mm	T in mm
Order width ≤ 4750	± 5	Order length ≤ 6330	± 5

Structural engineering calculation/CE mark

The L50 View is structurally calculated in accordance with the provisions of DIN EN 1090, using the regulations of Eurocode 9 (DIN EN 1991-1-3, 1991-1-4, 1999-1-1) (structural analysis). A type-tested structural analysis with structural calculations is available for our Lamaxa slat roofs L50, L60 and L70. This type-tested structural analysis forms the basis for the preparation of individual structural calculations by a qualified specialist. Individual structural analyses, as required by some authorities, must be prepared by the customer; this also applies to installation on a balcony/roof patio. Structurally designed foot plates can be requested if required. The load assumptions were made in accordance with DIN EN 1991-1-1 and the relevant standards.

L50 View	L50/L60/L70
-	EC Declaration of Conformity according to EN 13561
CE mark according to DIN EN 1090	CE mark according to EN 13561 (MRL)

CE conformity, declarations of conformity and declarations of performance can be found on our homepage under CE and Declarations of Performance.

Other information required for structural calculations can be found in the slat roof guidelines (IVRSA).

Planning permission

Each country or federal state has its own building regulations. Some paragraphs specifically deal with the topic of requirements and freedoms as related to permits or to procedures. It is necessary to check whether the Lamaxa has procedure-related requirements. The property owner is responsible for clarification. The building supervisory authorities provide information on whether or not the unit requires a permit. Clarification of and compliance with the applicable requirements, such as the observance of distance areas, the specifications of a development plan, etc., must be ensured as one's own responsibility and are not the responsibility of WAREMA. Furthermore, it must be checked as one's own responsibility whether another permit may be required. Any approval costs and costs for preparing the substructure (e.g. foundations) must be taken into account.

Alignment to the sun

Explanation

The Lamaxa slat roof should always be aligned so that the slats are perpendicular lengthways to the sunlight for as long as possible. This allows direct solar radiation to be minimised while maximising daylight utilisation at the same time. The dimensions of the Lamaxa slat roof should still be set such that the glass and window fronts are covered to the greatest possible extent, but no pole restricts the viewing area of glass or window fronts. L70: In order to maximise the light yield inside the house, especially in winter, the package should be planned on the side facing away from the house wherever possible, if the Lamaxa slat roof is close to the house facade. This prevents the shadow created by the package from falling inside the house.

Alignment of a patio facing south, south-east or south-west

This means that for a south, south-east or south-west facing patio, the slats should be aligned as parallel as possible to the house wall.

Alignment of a patio facing north, east or west

For a patio facing north, east or west, on the other hand, we recommend aligning the slats vertical to the house wall.

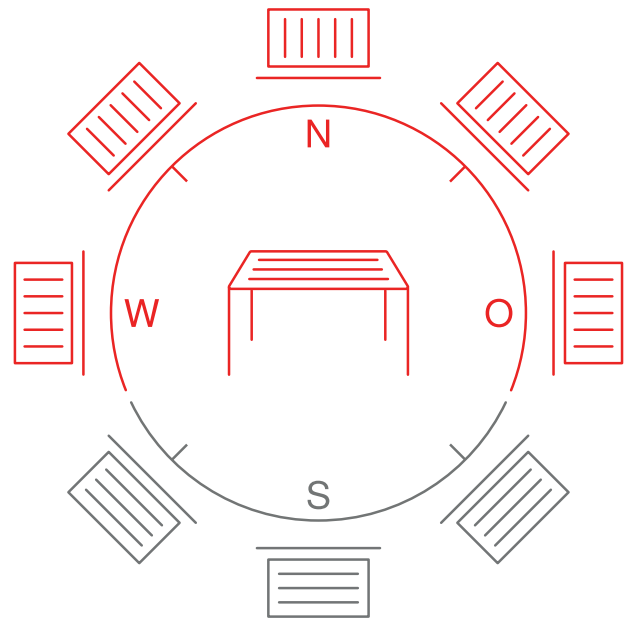

Direction of rotation of the slats

Explanation

The alignment of the slats (angle) also has a great impact on solar radiation. Depending on the alignment of the slats, the incidence of light is reduced or increased when the slats are opened.

Ideal alignment of the Lamaxa slat roof in summer (light is blocked more quickly)

The alignment of the Lamaxa slat roof and the alignment of the slats (angle) mean that the area to be shaded is protected from solar radiation from the south when the roof is opened. Grey area is the protected area.

Ideal alignment of the Lamaxa slat roof in winter (light is let in more quickly)

The alignment of the Lamaxa slat roof and the alignment of the slats (angle) cause light to be let in more quickly. Grey area is the protected area.

Direction of rotation of the slats - use in winter

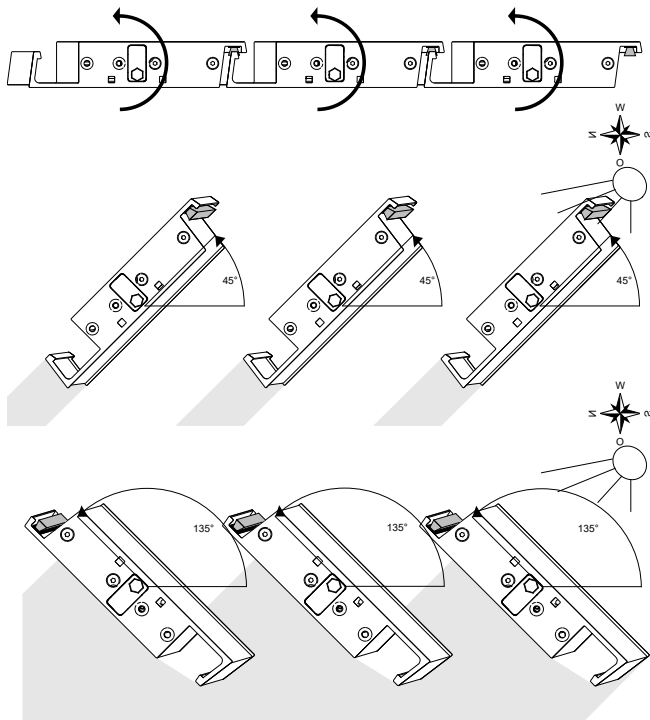

The slats turn in such a way that light is let in more quickly.

Direction of rotation of the slats - use in summer

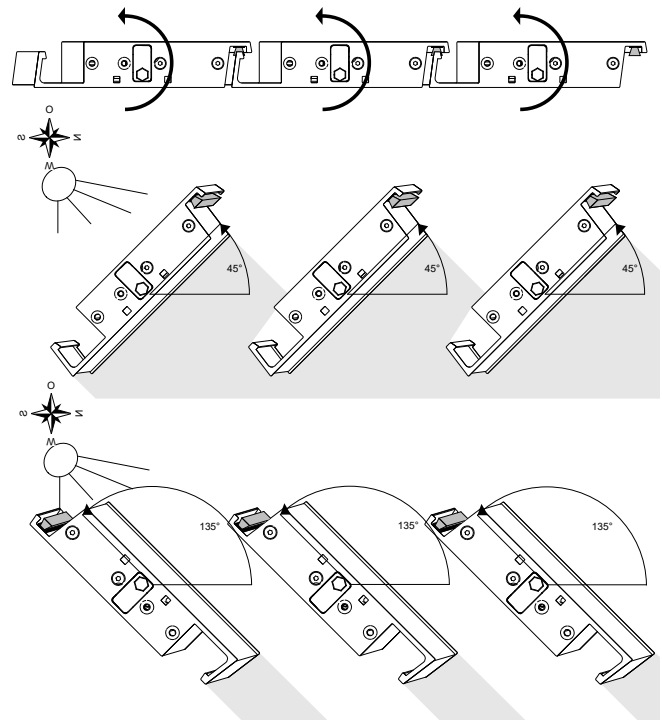

The slats turn when opened to provide protection from solar radiation from the south.

Slat roof guidelines

The association IVRSA has issued guidelines for slat roofs that provide a framework for the entire industry in line with the current state of the art. The guidelines can assist with consultations, planning and assembling slat roofs and can help you find solutions to potential issues and complaints: https://ivrsa.de/technische_unterlagen/

Connection/Connecting line

The mains connection is located inside the slat roof. Connecting lines for the accessory components ordered are preassembled at the factory. For slat roofs (L50, L60, L70) and L50 Tex, only one on-site connecting line ($5 \times 2.5 \text{ mm}^2$) is required for the complete roof system. For the L50 view, one $3 \times 2.5 \text{ mm}^2$ connecting line is required. The more detailed recommendation for the on-site connecting line is provided in the table headed "Number of channels and dimmers depending on the equipment".

Number of channels and dimmers depending on the equipment

Number of channels and dimmers depending on the equipment - Lamaxa

Equipment	L70	L60	L50	L50 View	L50 Tex	Number of channels	Number of dimmers	Minimum requirement for on-site connection	Power consumption
Tilt	-	x	x	-	-	1 channel	-	230 VAC / 16 A (3 x 2.5 mm ²)	approx. 200W
Tilt and move	x	-	-	-	-	1 channel	-	230 VAC / 16 A (3 x 2.5 mm ²)	approx. 2x200W
Integrated awning with easyZIP guidance	x	x	-	-	-	1 channel per unit	-	230 VAC / 16 A (3 x 2.5 mm ²)	approx. 200W
GranTex with easyZIP guidance	-	-	x	x	x	1 channel per unit	-	230 VAC / 16 A (3 x 2.5 mm ²)	approx. 200W
Two-sided LED lighting on the crossbeam - direct or indirect (crossbeams b and d)	x	x	x	-	x	1 channel	1 dimmer	230 VAC / 16 A (3 x 2.5 mm ²)	approx. 200W
Two-sided LED lighting on the crossbeam - direct and indirect (crossbeams b and d)	x	x	x	-	x	2 channels	2 dimmers	230 VAC / 16 A (3 x 2.5 mm ²)	approx. 200W
Four-sided LED lighting on the crossbeam - direct or indirect (crossbeams a to d)	x	x	x	-	x	1 channel	1 dimmer	230 VAC / 16 A (3 x 2.5 mm ²)	approx. 200W
Four-sided LED lighting on the crossbeam - direct and indirect (crossbeams a to d)	x	x	x	-	x	2 channels	2 dimmers	230 VAC / 16 A (3 x 2.5 mm ²)	approx. 200W
Two-sided RGB lighting on the crossbeam - indirect	x	x	x	-	x	via separate hand-held transmitter or app operation	One dimmer, dimmable via separate hand-held transmitter or app operation	230 VAC / 16 A (3 x 2.5 mm ²)	approx. 200W
Four-sided RGB lighting on the crossbeam - indirect	x	x	x	-	x	via separate hand-held transmitter or app operation	Two dimmers, dimmable via separate hand-held transmitter or app operation	230 VAC / 16 A (3 x 2.5 mm ²)	approx. 200W
LED lighting in pole (regardless of number of fields)	x	x	-	-	-	1 channel	1 dimmer	230 VAC / 16 A (3 x 2.5 mm ²)	approx. 200W
LED lighting on the pole (regardless of number of fields)	-	-	x	x	x	1 channel	1 dimmer	230 VAC / 16 A (3 x 2.5 mm ²)	approx. 200W
LED lighting in the slat(s)	-	x	x	-	-	1 channel	1 dimmer	230 VAC / 16 A (3 x 2.5 mm ²)	approx. 200W
LED lighting in rafters	-	-	-	x	-	1 channel	1 dimmer	230 VAC / 16 A (3 x 2.5 mm ²)	approx. 200W
Design radiant heater (separate fuse C16 required)	x	x	x	-	x	1 channel	1 dimmer (optional)	3x230 VAC / 16 A (5x2.5 mm ²)	2200 W

Equipment	L70	L60	L50	L50 View	L50 Tex	Number of channels	Number of dimmers	Minimum requirement for on-site connection	Power consumption
Power socket	x	x	x	x	x	-	-	3x230 VAC / 16 A (5x2.5 mm ²)	-
W10/W20	-	-	-	x	-	1 channel	-	230 VAC / 16 A (3 x 2.5 mm ²)	approx. 200W
Extend/retract awning	-	-	-	-	x	1 channel	-	230 VAC / 16 A (3 x 2.5 mm ²)	approx. 200W

Installation:

- The clamping area of the screw connection for the on-site connecting line is 9–16 mm.
- The required cross-section of the on-site connection must be defined by the qualified motor operation specialist in accordance with the applicable standards and local conditions.
- Connection box for L50: As soon as one or more electronic accessory variants are selected, electrical distribution takes place in a connection box on the crossbeam field c (see surcharge for L50). If no electronic accessories are selected, the connection is made by line in the crossbeam - regardless of the number of poles.

Notes:

- **WMS product configuration:** The relevant WMS studio pro file (.wmssp file) and a parametric log are available to download from myWAREMA once the commission has been processed. WMS studio pro can be used to retrieve this file and conveniently change the settings, in order to incorporate the accessories into the WMS network and learn them in, for example.
- **Number of channels:** Additional channels on the hand-held transmitter allow retrofitting at a later time.
 - Example: L70 slat roof with two integrated awnings with easyZIP guidance, direct and indirect LED lighting, radiant heater (dimmable) and power socket. This equipment is operated via 6 channels.
- **Number of dimmers:**
 - Example: L50 with 2-sided LED lighting on crossbeam (direct), 2-sided RGB lighting on crossbeam (indirect), integrated LED lighting in 3 slats. This version includes 3 dimmers.
- **Number of power consumers** A maximum of 9 power consumers can be connected to the electrical distribution as standard. Power sockets and radiant heaters are not considered power consumers in this regard. If more than 9 power consumers are required, an additional 230 V AC distributor will be installed (subject to surcharge). Example: L70 with LED lighting in the post, two-sided LED lighting on the crossbeam (direct and indirect), lighting in 2 slats, WMS weather station and two integrated awnings with easyZIP guidance. This version includes 7 power consumers.

Rain

A Lamaxa slat roof is an open outdoor canopy made from aluminium rather than a self-contained insulated conservatory. Therefore, 100% water-proof construction cannot be guaranteed. The frame construction is not guaranteed to be completely water-proof. Depending on the version, it offers protection against wind, rain and snow.

- Lamaxa is provided with a drainage system that is able to cope with the most frequently occurring rainfall.
- When closed, the slats or glass roofing protect the patio from rain.
- Furnishing and floor coverings must therefore be suitable for outdoor use.
- Raindrops can enter the interior in cases of:
 - Rain events heavier than those examined by WAREMA*
 - Opens after a downpour
 - Splashing of rainwater from the drainage gutter (largely but not completely prevented by splash protection profile)
 - Condensation that can form depending on the weather
 - Strong or changeable gusts of wind
 - Drops can form on the frame and poles

The setup, positioning, installation, sealing and product variant as well as extreme and unusual weather conditions can unexpectedly impact water tightness.

The Lamaxa drainage outlets should be selected so that they are located on the side facing away from the facade.

Lamaxa fabric roofs

The Lamaxa L50 Tex fabric roof with moveable, non-weatherproof awning fabric is a sun shading system and needs to be immediately retracted when it starts to rain.

If an awning fabric has been retracted when wet, the awning must be extended again as soon as possible for drying. We must point out that moisture can increase wrinkling when winding the unit in. To prevent the fabric from getting wet, we recommend automatic control according to sun, wind, rain and time of day, using a WAREMA control unit.

* Examined rain event for Lamaxa slat roofs and glass roofs:

- Lamaxa withstands a medium rain event occurring every 2 years for 5 minutes [(350l/(s*ha) equivalent to 126l/(h*m²)]
- Lamaxa permanently withstands rain class 2 (56l/h*m²) in accordance with DIN EN 13561
- Requirements:
 - <16 m² roof surface (order width*order length), min. 1x drainage is required.
 - For ≥16 m², a minimum of 2 drainage points are required in the pole.
 - The rain tests refer to a free-standing standard roof and not to a wall connection, as water from the facade may be added there.

Wind

Lamaxa slat roofs are able to withstand a maximum permissible wind speed of 13.4 m/s according to statistical calculations in accordance with DIN 1991-1-4 'Actions on substructures'. For wind speeds > 13.5 m/s, two adjustment positions can be configured for the slats, depending on the order length:

- Order length > 5.1 m: Slat opened to at least 90°
- Order length ≤ 5.1 m: Slat closed

Lamaxa fabric roofs achieve wind resistance class 4 in accordance with DIN EN 13561 with a maximum permissible wind speed of 13 m/s.

Beaufort table

The following Beaufort table contains the average wind speeds allocated to Beaufort degrees and describes the effect of the wind.

Beaufort level	Designation	Average wind speed m/s	Average wind speed km/h	Levels for determining the wind speed limits m/s	Back pressure q (average value) in N/m ²	Examples of the effects of inland wind
0	Calm	0–0.2	<1	0	0	Smoke rises vertically
1	Slight draught	0.3–1.4	1–5	0	0.6	Wind direction indicated by the draught of the smoke
2	Light breeze	1.5–3.4	6–12	1	6	Wind can be felt in the face, leaves rustle, vanes begin to move
3	Light breeze, light wind	3.5–5.4	13–19	3	16	Wind moves thin twigs and stretches pennants
4	Moderate breeze, moderate wind	5.5–7.4	20–27	5	30	Wind causes twigs and small branches to move, raises dust and loose paper
5	Fresh breeze, fresh wind	7.5–10.4	28–37	7	60	Small trees in leaf begin to sway, white crests begin to form on lakes
6	Strong wind	10.5–13.4	38–48	10	110	Strong branches sway, umbrellas are difficult to control, telegraph cables howl in the wind
7	High wind	13.5–17.4	49–62	13	160	Effort needed to walk against the wind, whole trees in motion
8	Gale	17.5–20.4	63–73	17	230	Twigs break off trees, walking is quite difficult
9	Strong gale	20.5–24.4	74–87	20	330	Branches break off trees, minor damage to buildings (roof tiles or smoke hoods are lifted off)
10	Heavy storm	24.5–28.4	88–102	24	460	Wind breaks trees, extensive damage to buildings
11	Violent storm	28.5–32.4	103–117	28	600	Wind uproots trees, wide-spread storm damage
12	Hurricane	From 32.5	From 118	32	770	Serious devastation

Load bearing capacity

L60/L70: Both slat roof types have a max. load-bearing capacity of up to 350 kg/m².

L50: The Lamaxa slat roof L50 has a max. load-bearing capacity of up to 230 kg/m².

The tests were performed without stabilisation such as additional supports, tension cables or similar. A load of this kind will lead to permanent deformation of the profiles. With smaller dimensions or additional poles, the Lamaxa slat roof can bear significantly larger loads. If the maximum load-bearing capacity is exceeded, the slat roof may be destroyed.

Snow

When they are closed, **Lamaxa slat roofs** have a max. permissible snow load that varies depending on their size (see table below).

As soon as snow lies on the closed slats and/or the slat roof is iced over, the slats must no longer be moved. The full functionality will be available again only after the snow and ice have fully melted.

The permissible snow depth changes according to the snow density. To prevent the slat roof becoming overloaded, we recommend moving the slats into an open, middle slat position (90°) when snow starts to fall. This protects the Lamaxa from excessive loads.

Before the stated maximum snow load is reached, the roof must be cleared of snow as this can otherwise lead to permanent damage.

The Lamaxa slat roof must not be used in icy conditions.

Lamaxa glass roofs

The specified snow loads apply to Lamaxa L50 View. The required snow load must be determined according to the snow load zone of the installation site by the responsible qualified specialist or requested by the customer. If the Lamaxa L50 View is exposed to a higher snow load, the roof must be freed from the load, e.g. by removing the snow.

Lamaxa fabric roofs

The Lamaxa L50 Tex must not be used in snowy conditions. An awning is only intended as a sun shading system.

Roof avalanches from nearby buildings may damage the slat roof.

Heavy snowfall and sleet are possible in winter. As temperatures rise, accumulated snow may slide off of unprotected and smooth areas (e.g. house roof with or without solar panels) and drop down onto the slat roof. This may damage the slat roof.

- If falling snow cannot be prevented entirely, suitable measures must be taken to avoid the uncontrolled falling of snow.
- It is advisable to install snow grates in the slat roof area or snow guards along the entire roof.

Maximum snow load Lamaxa L60/L70

Maximum snow load for Lamaxa slat roof L60/L70 (kg/m²)

Width	2500 mm	2750 mm	3000 mm	3250 mm	3500 mm	3750 mm	4000 mm	4250 mm	4500 mm	4750 mm
Length										
2000 mm	300	260	210	170	140	115	90	70	52	28*
2178 mm	300	260	210	170	140	115	90	70	52	28*
2398 mm	300	260	210	170	140	115	90	70	52	28*
2618 mm	300	260	210	170	140	115	90	70	52	28*
2838 mm	300	260	210	170	140	115	90	70	52	28*
3058 mm	300	260	210	170	140	115	90	70	52	28*
3278 mm	300	260	210	170	140	115	90	70	52	28*
3498 mm	300	260	210	170	140	115	90	70	52	28*
3718 mm	300	260	210	170	140	115	90	70	52	28*
3938 mm	300	260	210	170	140	115	90	70	52	28*
4158 mm	300	260	210	170	140	115	90	70	52	28*
4378 mm	300	260	210	170	140	115	90	70	52	28*
4598 mm	300	260	210	170	140	115	90	70	52	28*
4818 mm	300	260	210	170	140	115	90	70	52	28*
5038 mm	300	260	210	170	140	115	90	70	52	28*
5258 mm	300	260	210	170	140	115	90	70	52	28*
5478 mm	300	260	210	170	140	115	90	70	52	28*
5698 mm	280	260	210	170	140	115	90	70	52	28*
5918 mm	260	250	210	170	140	115	90	70	52	28*
6000 mm	250	240	210	170	140	115	90	70	52	28*
6138 mm	240*	230*	210*	170*	140*	115*	90*	70*	52*	28*
6330 mm	230*	220*	210*	170*	140*	115*	90*	70*	52*	28*

* only applies to Lamaxa L60

Maximum snow load Lamaxa L50

Maximum snow load for Lamaxa slat roof L50 (kg/m²)

Width	2000 mm	2250 mm	2500 mm	2750 mm	3000 mm	3250 mm	3500 mm	3750 mm	4000 mm	4250 mm	4500 mm
Length											
2060 mm	300	300	275	180	155	120	90	75	60	55	50
2280 mm	300	300	275	180	155	120	90	75	60	55	50
2500 mm	300	300	275	180	155	120	90	75	60	55	50
2720 mm	300	300	275	180	155	120	90	75	60	55	50
2940 mm	300	300	275	180	155	120	90	75	60	55	50
3160 mm	300	300	275	180	155	120	90	75	60	55	50
3380 mm	300	300	275	180	155	120	90	75	60	55	50
3600 mm	300	300	275	180	155	120	90	75	60	55	50
3820 mm	300	300	275	180	155	120	90	75	60	55	50
4040 mm	300	300	275	180	155	120	90	75	60	55	50
4260 mm	300	300	275	180	155	120	90	75	60	55	50
4480 mm	300	300	275	180	155	120	90	75	60	55	50
4700 mm	300	300	275	180	155	120	90	75	60	55	50
4920 mm	300	300	260	180	155	120	90	75	60	55	50
5140 mm	300	260	240	180	155	120	90	75	60	55	50
5360 mm	270	245	210	175	155	120	90	75	60	55	50

Width	2000 mm	2250 mm	2500 mm	2750 mm	3000 mm	3250 mm	3500 mm	3750 mm	4000 mm	4250 mm	4500 mm
5580 mm	235	215	180	160	150	120	90	75	60	55	50
5800 mm	200	190	160	140	130	120	90	75	60	55	50
6020 mm	160	145	125	115	100	95	90	75	60	55	50

Roof patios

The Lamaxa L50, L60 and L70 is suitable for a structure on roof patios. The static requirements and load values that apply to Lamaxa must be observed during planning and dimensioning. On-site measures must take into account the structural analysis of the system and comply with the requirements from the technical documents for Lamaxa L50/L60/L70.

The following criteria must be taken into account in the planning:

- Weights of the product
- Floor load-bearing capacity
- Installation height
- Fixing options (e.g. fixing in the substructure/base plate weightings)
- Sealing level (sealing the on-site spacing-base consoles)
- Occurring winds due to terrain category and wind load zone
- Load limit values for wind and snow. Vertical fixtures such as ZIP awnings, fixed walls, glass sliding system or sliding shutters must be taken into account without fail.

To avoid damage from exposure to wind and water, the product must be controlled via weather sensors.

A structural engineer, planner or architect must carry out the calculation and production of the fastening structure for base plates, foundations, bolting at the sealing level or larger weighting plates. Larger base plates serve as a weight and substitute for a fixing.

Disclaimer

WAREMA accepts no liability for on-site structural analyses, fixing and dimensioning of base plates outside of the standard range. The manufacturer warranty exclusively applies subject to adherence with the installation and operating instructions and the intended use of the product.

Touch-up pens

Minor visual defects on powder-coated WAREMA products can be quickly and easily repaired on-site using the touch-up pen. The touch-up pens are optimally matched to the powder used by WAREMA and guarantee a perfect installation result. They can be ordered from myWAREMA or Amazon. A touch-up pen is included in the accessories for the following frame colours: R7015F, R9016F, R7016F, W4914F, W4915F, W4916F, W4917F, W4818F, DB702F, R7021F, R7035F, R9005F, R9010F, R7012F, R7039F.

Mounting example for roof patios

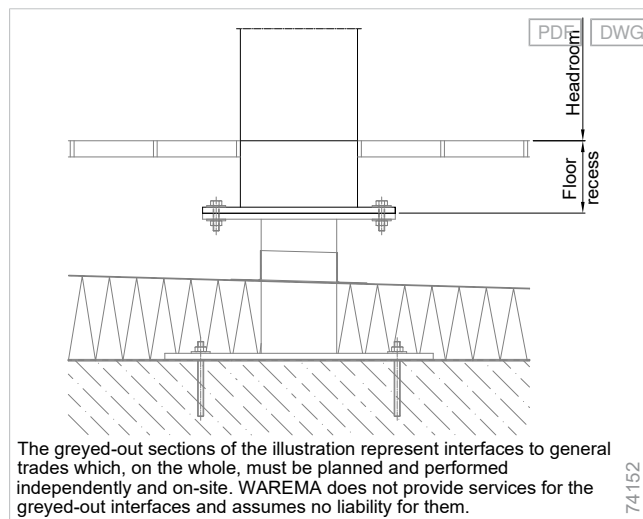

The mounting options, incl. sealing level, vary depending on the installation situation. Poles and base plates must not be sealed into the sealing level as well.

Installation lift

For individual units L50/L60/L70

The use of an electrical installation lift is recommended to install the individual units of the Lamaxa L50/L60/L70 slat roof. The portable electric installation lift is rated for a load of up to 140 kg and reaches an installation height of up to 4900 mm. It can be assembled without tools and aligned quickly and easily.

Not suitable for series-mounted unit Lamaxa L60/L70 Line.

For L60/L70 Line series-mounted units

A mechanical installation lift with a higher load-carrying capacity is required to install Lamaxa L60/L70 slat roof series-mounted units. The installation lifting device is rated for a load of up to 250 kg. A firm and level substructure is required for optimal use of the lifting device.

WAREMA offers the following options:

- "Mechanical installation lifting device incl. rotating device on the load fork" available to purchase via Service
- WAREMA Service "Lamaxa Line installation training incl. installation lifting device". The lifting device remains the property of WAREMA and is only made available during installation.

For Lamaxa L50 View glass roof

A glass suction system incl. adapter for overhead installation is required to install the Lamaxa L50 View glass roof. The glass suction unit is rated for a load of 300 kg (can be increased to 450 kg).

Planning requirements - L50 Line and Star unit

The following points must be ensured by the specialist partner:

- Possibility of unloading several packaging units depending on the number of fields on site
- Fixing in the substructure and possible use of special consoles
- Foundation planning incl. drainage and power supply
- Examination of the need for a separate, type-tested structural analysis for the construction project
- Examination of any other official regulations
- Request for the desired operating options and controls

The following points must be ensured with regard to electrical planning:

- Examination of the need for line plans (designed at WAREMA with individual planning)
- Planning and determination of the technically feasible equipment features of the roof fields
- On-site fuse protection of the electrical connections
- Planning and connection by qualified motor operation specialists
- Definition of the dimensions of the connecting lines to the roof bays depending on the equipment (ZIP, lighting, heaters, external sockets, etc.)
- Consideration of separate connecting lines depending on the wattage of the accessories
- Definition of the connecting line positions in the roof bays/assignment of which lines are inserted at which supports
- Please note that retrofitting of electronic accessory variants is no longer possible once the electrical planning has been finalised.

Sealing

Responsibility

On-site sealing is the responsibility of the specialist partner since the conditions on-site (e.g. the nature of the substructure) are not available to WAREMA. If a seal is required between the slat roof and the property (building wall/building), WAREMA recommends assigning the work to a specialist partner such as a plumber.

Disclaimer

WAREMA shall not be held liable for slat roofs that are not properly sealed toward the building (building, house wall, or similar) and any damage resulting from this. The manufacturer's warranty is strictly subject to compliance with the installation and operating specifications and to the intended use of the product.

Contents

Slat roofs Lamaxa

Slat roofs Lamaxa L70.....	26
Slat roofs Lamaxa L70 Line.....	42
Slat roofs Lamaxa L60.....	56
Slat roofs Lamaxa L60 Line.....	74
Slat roofs Lamaxa L50.....	88
Slat roofs Lamaxa L50 Line.....	100

Planning

Slat roofs
Lamaxa

Glass roofs
Lamaxa

Fabric roofs
Lamaxa

Supplementary
accessories

Drive
variants

Standards



Roof systems

Slat roofs Lamaxa L70

Year-round use

Protection in all weather: Depending on the type, the incidence of light can be adjusted to several levels with the tilting and moving slats – from a fully unobstructed view of the sky all the way to a complete, weather-proof closure of the slat roof.

Dry

Dryness guaranteed: Controlled drainage through integrated rain gutters and drainage in the pole.

Customisable

Can be individually equipped according to personal preference with diverse, optional extras such as integrated LED and RGB lighting, integrated awnings with easyZIP guidance, sash frames or radiant heaters.

Construction limit values

Maximum order width	4500 mm
Maximum order length	6000 mm
Maximum order area	27 m ²

Order here

myWAREMA

[Art.-Nr. 2056450](#)

WAREMA tools

[Sun Shading Planner](#)

[see "Navigating the document", Page 5](#)

Components

Slat roof Lamaxa L70

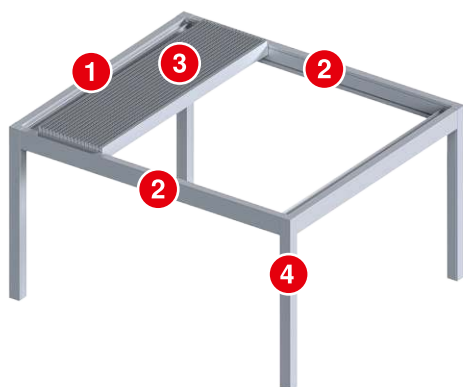

1	Crossbeam with motor	3	Slats
2	Crossbeam with tilting mechanics	4	Pole

Slat

Slat - L70

Material	Aluminium, extruded
Surface	Powder-coated
Width	235 mm
Height	45 mm
Swivelling range	0 - 135 °

Pole

Pole - L60/L70

Material	Aluminium, extruded
Surface	Powder-coated
Width	170 mm
Height	170 mm

Installation options:

- Ground installation with frost-proof, on-site foundation.
- The grout for filling the clearance is not included in the scope of delivery when threaded rods are used.

Floor recess and separation cut:

- For a floor recess, we recommend the use of a separation cut in the inspection parts to allow for inspection without dismantling the floor.
- If the floor recess does not have a separation cut, the easyZIP guidance inlays and the integrated LED strips reach the bottom edge of the pole profile.
- Floor recesses with a separation cut must be at least 60 mm.

Pole, optional

Pole guide rails - L60/L70

Material	Aluminium, extruded
Surface	Powder-coated
Width	170 mm
Height	170 mm

If an easyZIP awning is installed in a field in which a wall console is installed, a separate pole is required below the

wall console. Inward or outward drainage through guide rail poles possible. Only corner base plate possible.

Base plate

Base plate - corner installation L60/L70

Material	Galvanised steel
Surface	Plain
Optional surface	Powder-coated
Width	300 mm
Height	300 mm

Base plate - internal L60/L70

Material	Galvanised steel
Surface	Plain
Optional surface	Powder-coated
Width	170 mm
Height	170 mm

Since the material thickness is generally visible, the internal base plate should be coated if there is no floor recess.

Crossbeam

Crossbeam - L60/L70

Material	Aluminium, extruded
Surface	Powder-coated
Width	169 mm
Height	280 mm

Electrical distribution on the crossbeam

Material	Aluminium, extruded
Surface	Powder-coated
Width	91,5 mm
Height	174 mm

Drainage

Drainage in pole - L60/L70

- Drainage through drainpipe in pole
- In order to achieve rain class 2 with closed slats, at least one drainage point is required for a unit size smaller than 16 m² and at least two drainage points for a unit size larger than 16 m². If the minimum number of drainage points is not observed, rain class 2 is not achieved.

Position of drainage outlet:

- Possible on every pole
- Drainage and electronics/connecting lines must always be installed in separate poles.
- On the outsides of the poles or downward
- Min. height: 120 mm - 380 mm/height: 40 mm (for internal base plates)
- From 550 mm to 500 mm below the headroom

Note: Downward drainage through base plate:

When planning and measuring, please note that the concrete foundation must be very precisely manufactured if downward drainage through the base plate is required. The drainage does not sit centrally in the base plate.

Wall connection profile, optional

Wall connection profile with small rain hood

Material	Aluminium, extruded
Surface	Powder-coated
Width	54 - 65 mm
Height	48 mm
Dimensions, notes	The adjustment range in the depth between rain hood and wall connection profile is up to 11 mm.

The on-site sealing is the responsibility of the specialist partner; if necessary, the commissioning of a plumbing company is recommended.

Field of application:

- Terrea K50
- Terrea K70
- Perea P20 (up to an angle of 10°)
- Lamaxa L50/L60/L70

Console, optional

Wall console - Lamaxa L60/L70

Material	Galvanised steel
Surface	Powder-coated
Width	120 mm
Height	180 mm
Depth	140 mm

- Use in corner as pole replacement.
- A maximum of two poles can be replaced by wall consoles.
- For a concrete mounting substructure; adapter plates are required for other substructures.
- The wall console protrudes 11 mm beyond the order width and order length. This results in a gap of 11 mm between the crossbeam and the wall.
- For inner angle wall consoles, the lateral corner area is not covered by profiles.

Offset wall console - Lamaxa L60/L70

Material	Aluminium, extruded
Width	200 mm
Height	120 mm
Depth	120 mm

- For attachment to Tb and/or Td.
- Use in corner as pole replacement or as Free installation.
- A maximum of 4 poles can be replaced by offset wall consoles.
- For a concrete mounting substructure; adapter plates are required for other substructures.
- In the case of the Free installation version with offset wall console, the beam cover is omitted, creating a gap between the beam and the installation point. Angle bracket or cover on request.

Drive variants

- Motor

Motor

- WMS-LP (WMS)

⊕ see "Drive variants", Page 201

Colours

- WAREMA Colour World, Individual category, fine texture surface quality
- WAREMA Colour World, Highlight category, fine texture surface quality
- WAREMA Colour World, Variation category, fine texture surface quality

Colours, optional:

- WAREMA Colour World

⊕ see "Colours and finishes", Page 10

Notes

Notes on installation

Limit position learning:

The WAREMA Smart programming cable is required to set the motor limit positions.

Notes on operation

To ensure convenient and fast operation of the slat roof, we recommend WMS WebControl pro (control via smartphone, tablet, etc.) and WMS Weather station plus in order to use the control modes (e.g. sun control). To do so, a sufficiently strong radio reception must be ensured.

Supplementary accessories

- Design radiant heater
- Lamaxa lighting
- Integrated awnings with easyZIP guidance
- Additional pole - L60/L70
- Offset pole - L60/L70
- Glass sliding system SL20e
- Sliding shutters - L50/L60/L70
- Power socket

⊕ see "Supplementary accessories", Page 143

Construction limit values

Configuration variants	Minimum order width	Maximum order width	Minimum order length	Maximum order length	Maximum order area	Minimum headroom	Maximum headroom
Slat							
Slat - L70	2500 mm	4500 mm	2000 mm	6000 mm	27 m ²	1200 mm	2700 mm

Pole height:

- Minimum height for poles with drainage: 1200 mm
- Minimum height for poles without drainage: 550 mm
- Maximum pole height (headroom plus floor recess) is ≤ 3000 mm.

Dimensions:

- the order length/width corresponds to the outer dimensions from crossbeam to crossbeam
- the poles are 1 mm above the crossbeams on each side
- the cover panel (outside) is 2 mm above the crossbeams in each case

Dimension determination

The headroom of each pole can be ordered individually (e.g. in case of a sloping finished floor).

L70, field definition

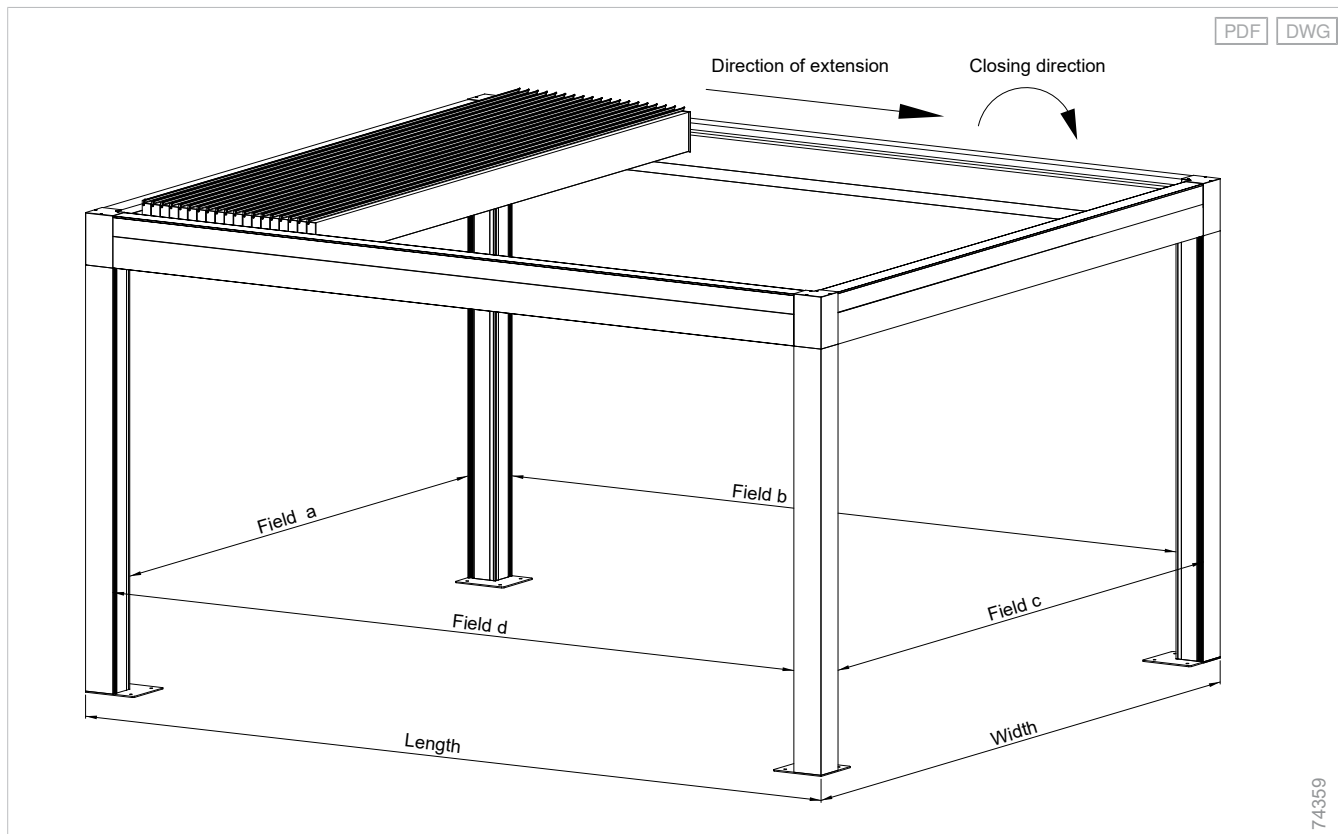

Top view of the position/connection points - L50/L60/L70

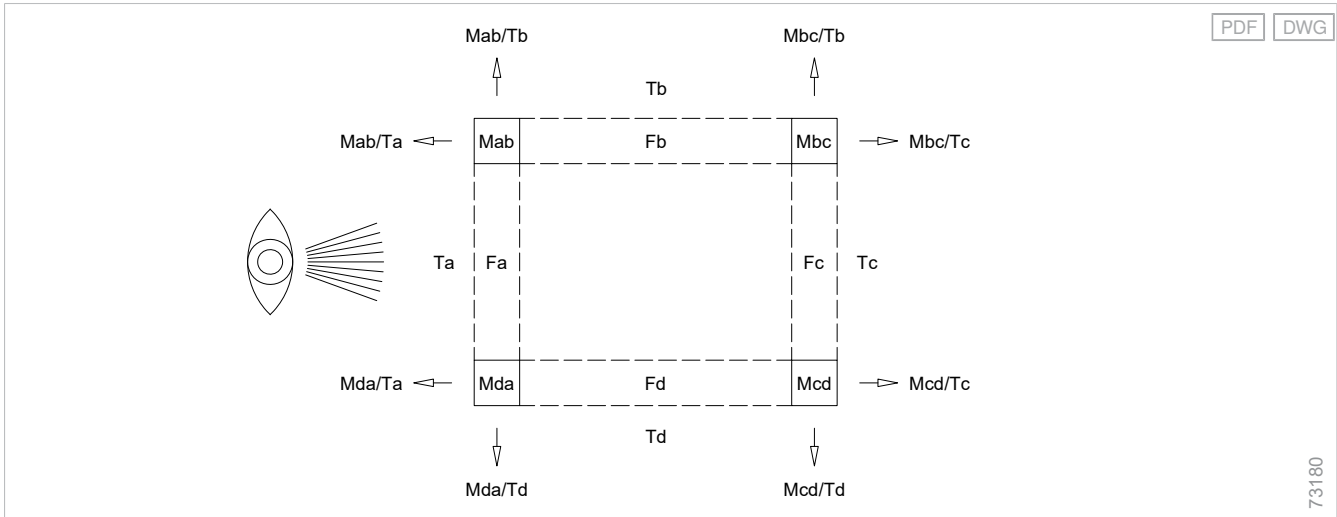

F Field
 M Point of installation (pole or wall connection)
 T Crossbeam

L70, open slats, side view

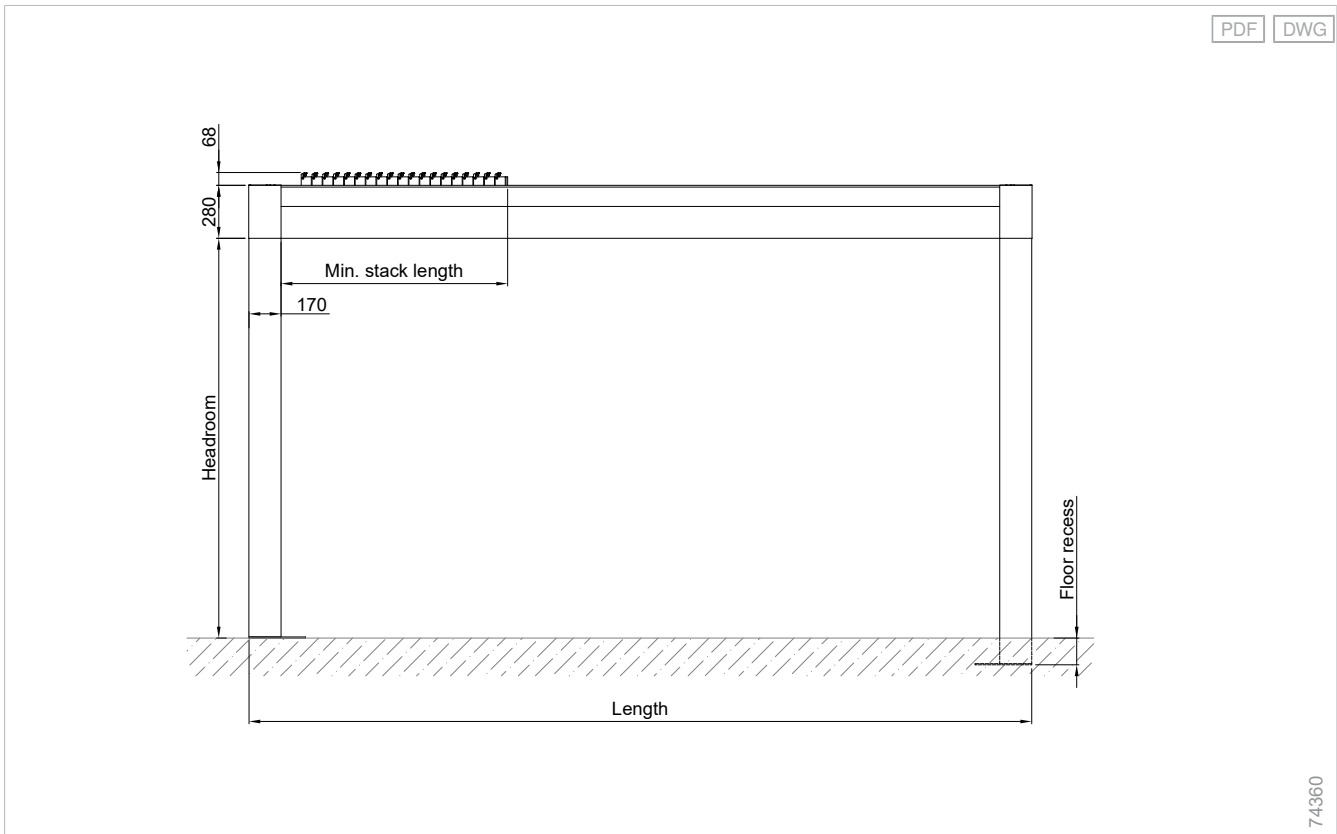

When closed, the slats do not protrude beyond the crossbeam.

L60/L70, wall console

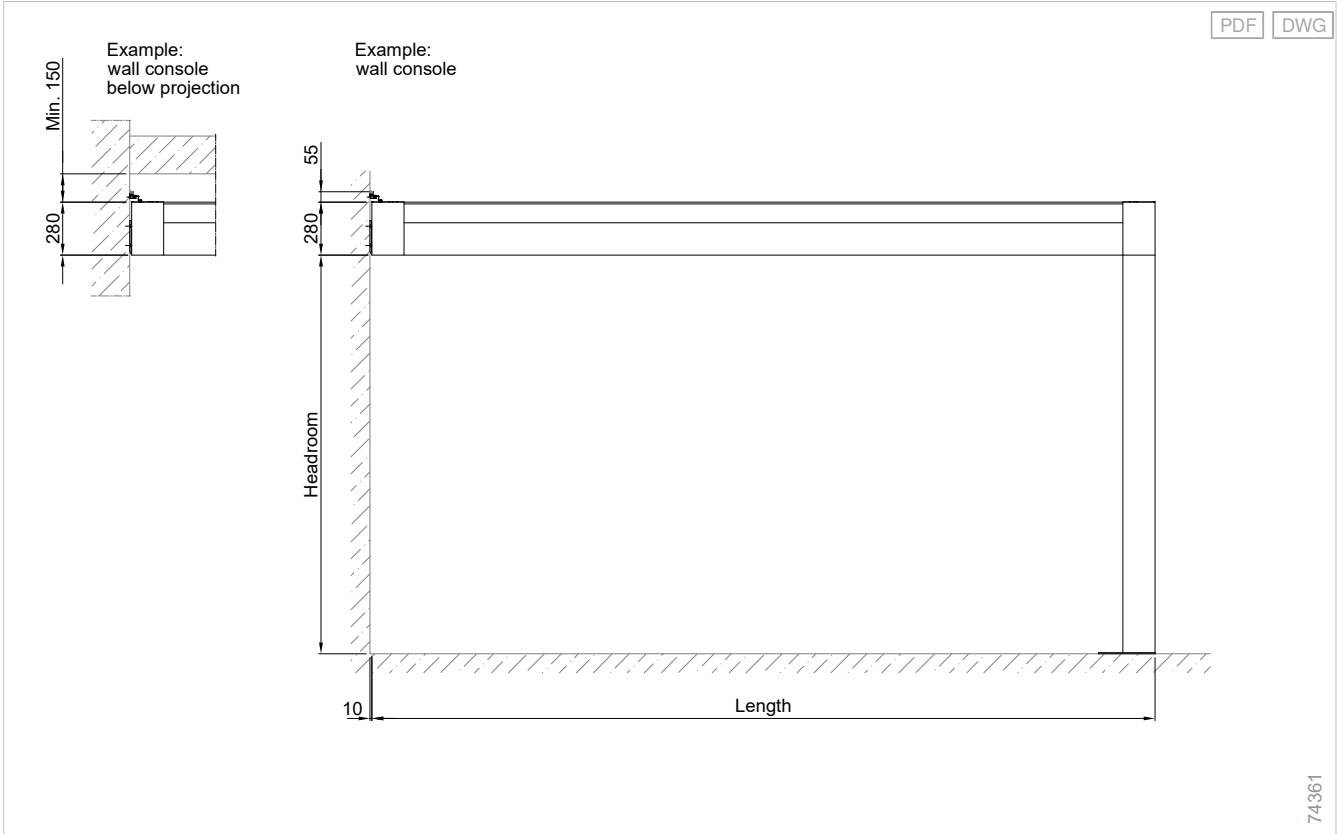

Planning

Slat roofs
Lamaxa

Glass roofs
Lamaxa

L60/L70, wall console, guide rail pole

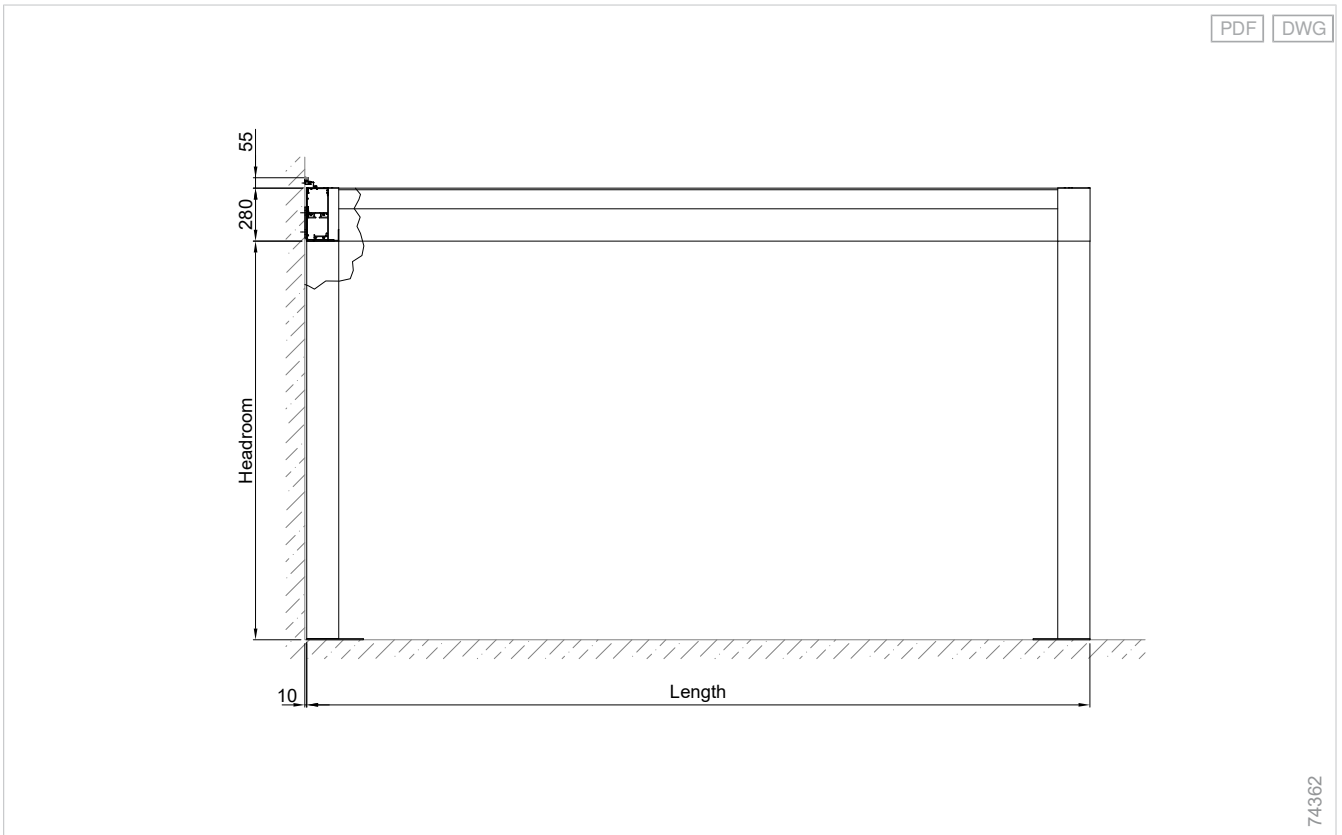

Fabric roofs
Lamaxa

Supplementary
accessories

Drive
variants

Standards

L60/L70, dimension determination, order dimension

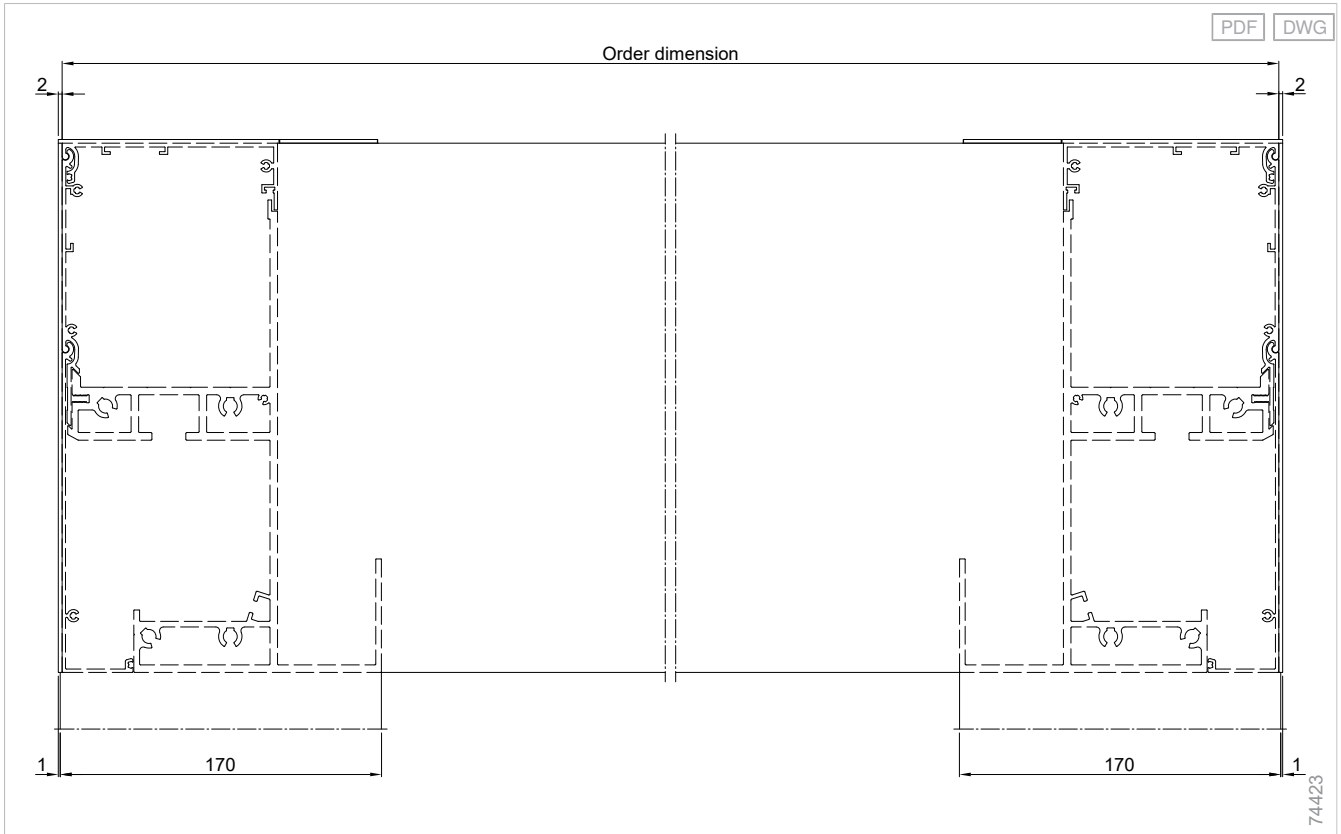

L60/L70, Free-installation with offset wall console

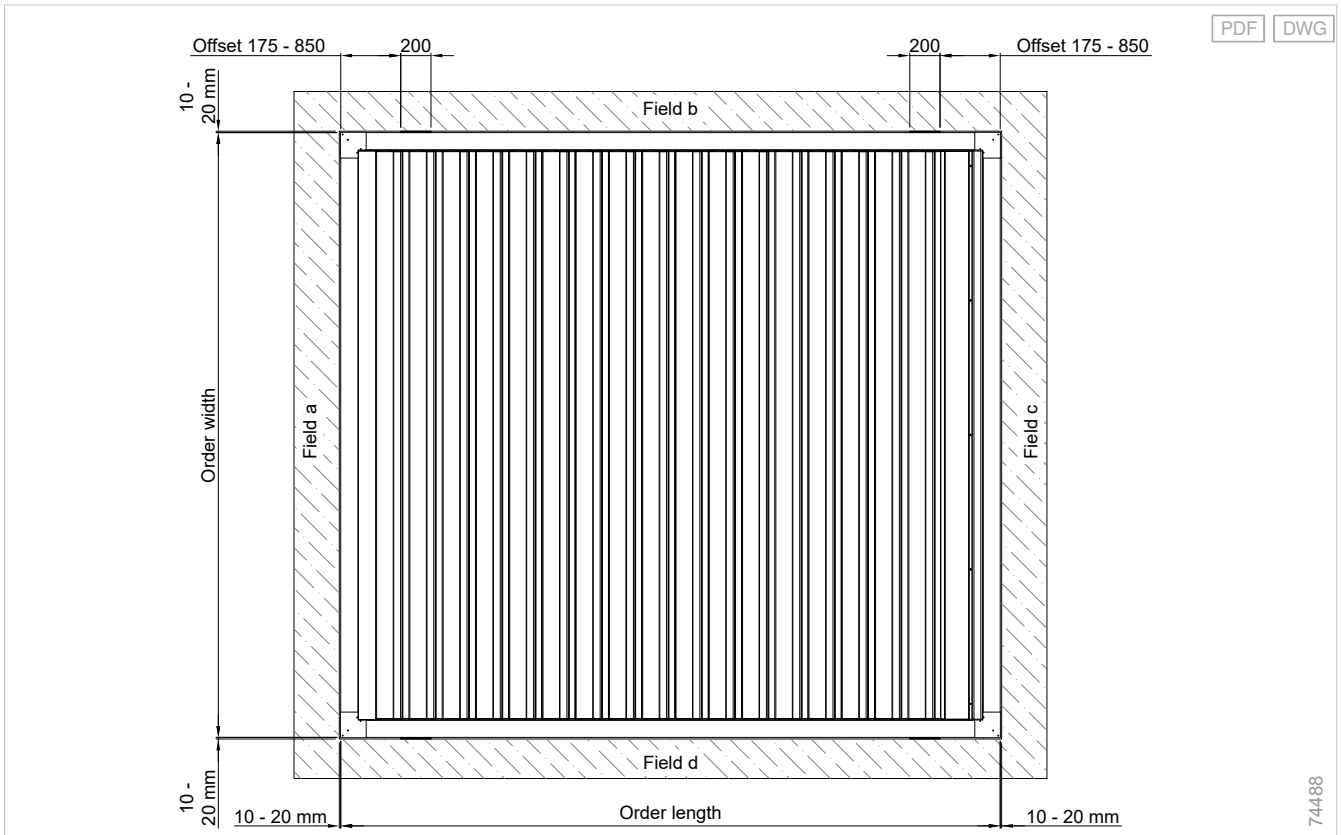

L60/L70, Free-installation with offset wall console

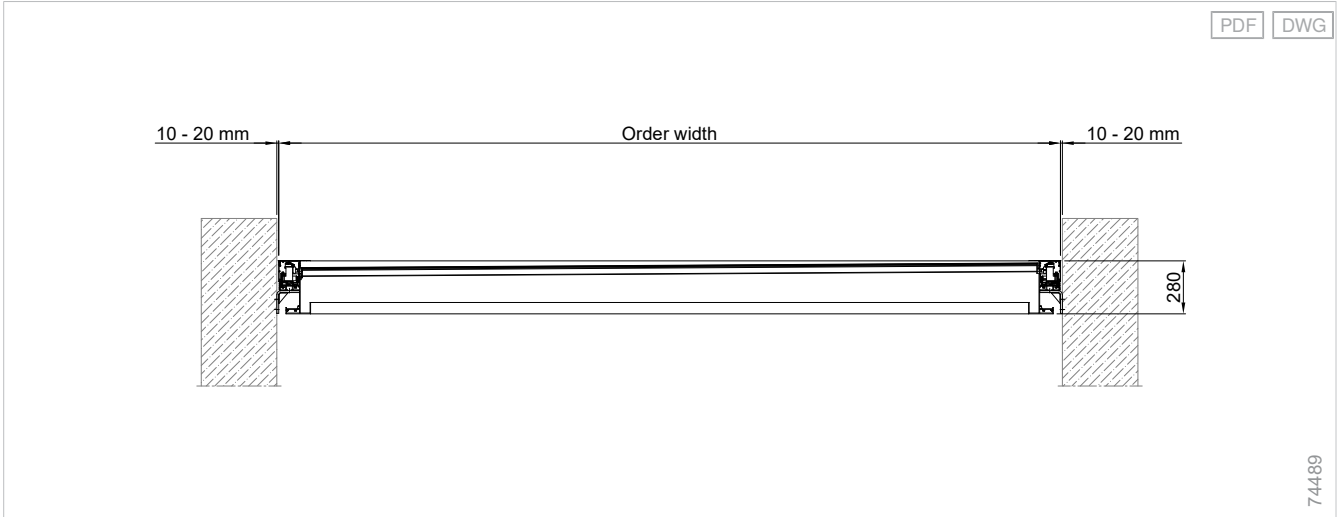

Planning

Slat roofs
Lamaxa

Glass roofs
Lamaxa

Fabric roofs
Lamaxa

Supplementary
accessories

Drive
variants

Standards

Weight assessment

Weight assessment for roof systems

Order length	Order width				
	2500 mm	2501 - 3000 mm	3001 - 3500 mm	3501 - 4000 mm	4001 - 4500 mm
2000 - 2500 mm	472 kg	503 kg	535 kg	566 kg	598 kg
2501 - 3000 mm	503 kg	537 kg	572 kg	607 kg	641 kg
3001 - 3500 mm	534 kg	571 kg	609 kg	647 kg	685 kg
3501 - 4000 mm	580 kg	623 kg	665 kg	708 kg	750 kg
4001 - 4500 mm	611 kg	657 kg	703 kg	748 kg	794 kg
4501 - 5000 mm	642 kg	691 kg	740 kg	789 kg	838 kg
5001 - 5500 mm	689 kg	742 kg	796 kg	850 kg	903 kg
5501 - 6000 mm	707 kg	762 kg	817 kg	873 kg	928 kg

Quantity determination

Number of slats

Order length	Number of slats	Stack length
2000 mm	7	566 mm
2178 mm	8	582 mm
2398 mm	9	640 mm
2618 mm	10	698 mm
2838 mm	11	756 mm
3058 mm	12	814 mm
3278 mm	13	872 mm
3498 mm	14	930 mm
3718 mm	15	988 mm
3938 mm	16	1046 mm
4158 mm	17	1104 mm
4378 mm	18	1162 mm
4598 mm	19	1220 mm
4818 mm	20	1278 mm
5038 mm	21	1336 mm
5258 mm	22	1394 mm
5478 mm	23	1452 mm
5698 mm	24	1510 mm
5918 mm	25	1568 mm

Order length:

- The order length in the table is the dimension with the smallest possible length equalization plates and hence corresponds to the optimum order dimension (except order length 2000 mm).

Stack length:

- The stack length refers to electrical distribution on the crossbeam in field c.
- If the electrical distribution is implemented on the crossbeam in field a, the stack length increases by 105 mm.

Details

L70, slat

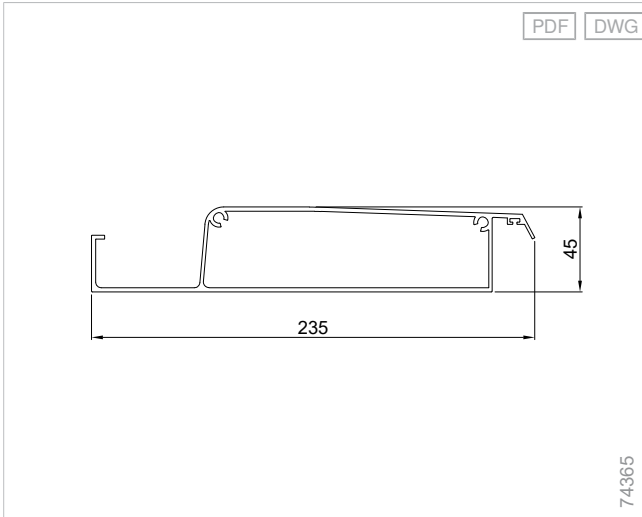

L60/L70, pole

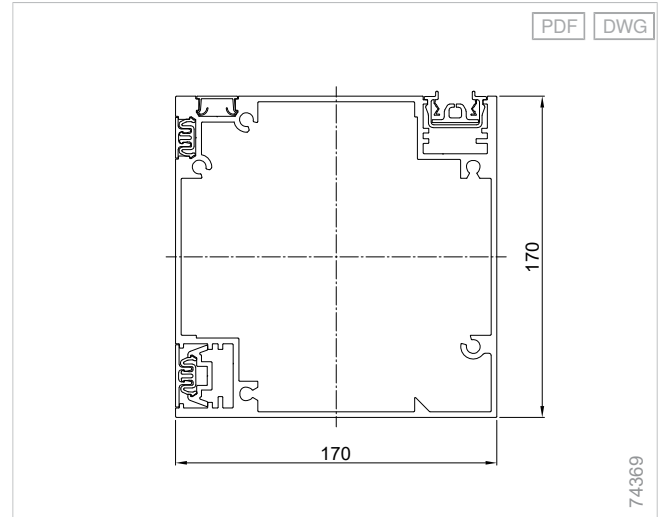

L60/L70, crossbeam a/c

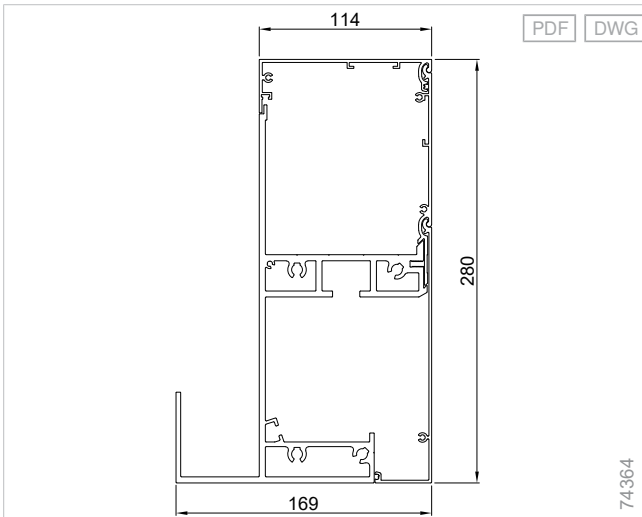

L60/L70, position of drainage, rectangular

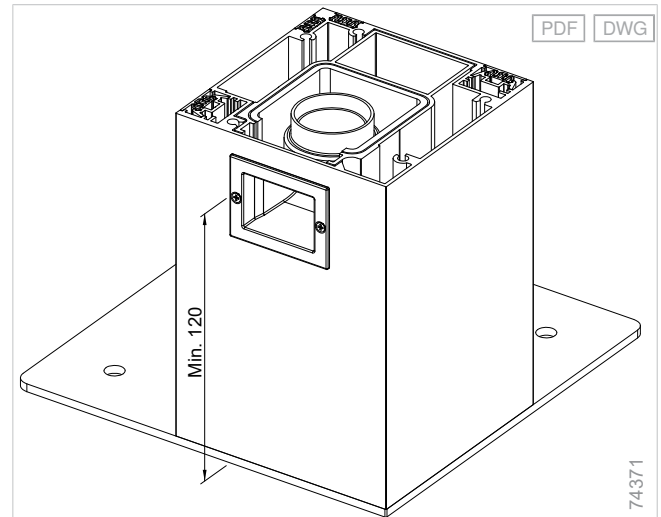

L70, crossbeam b/d, optional LED profile

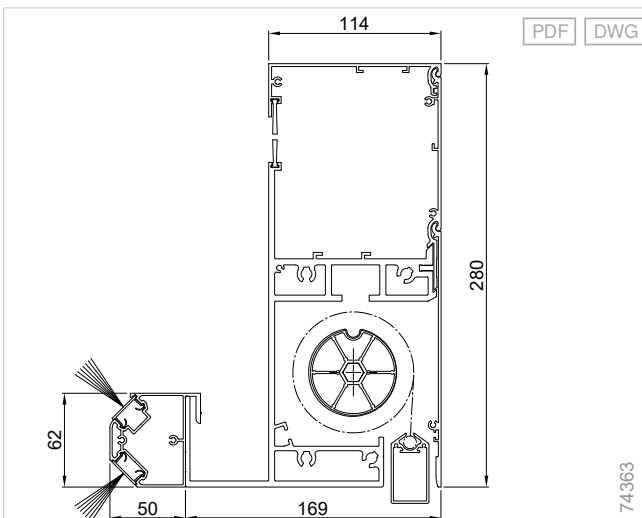

L60/L70, position of drainage, rectangular, optional waterspout

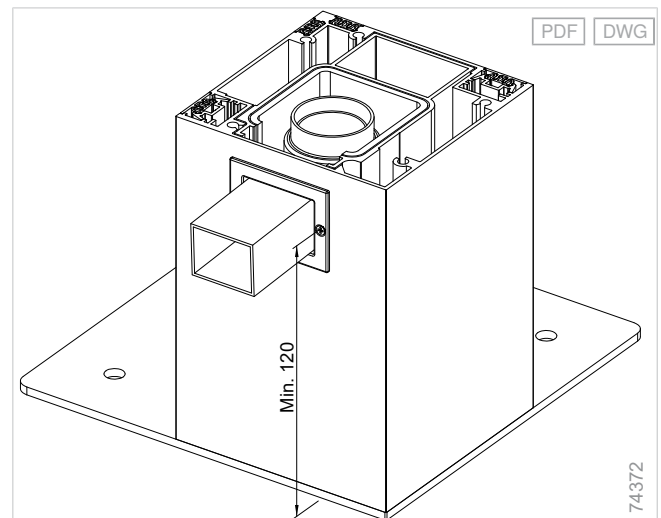

Planning

Slat roofs
Lamaxa

Glass roofs
Lamaxa

Fabric roofs
Lamaxa

Supplementary
accessories

Drive
variants

Standards

L60/L70, position of drainage, on-site

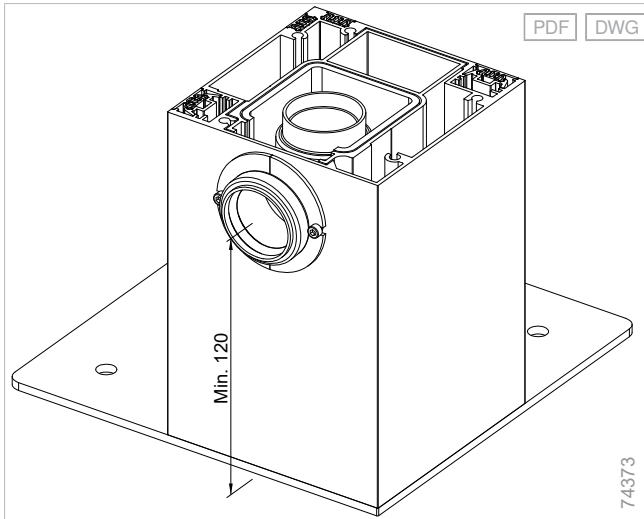

L60/L70, offset wall console

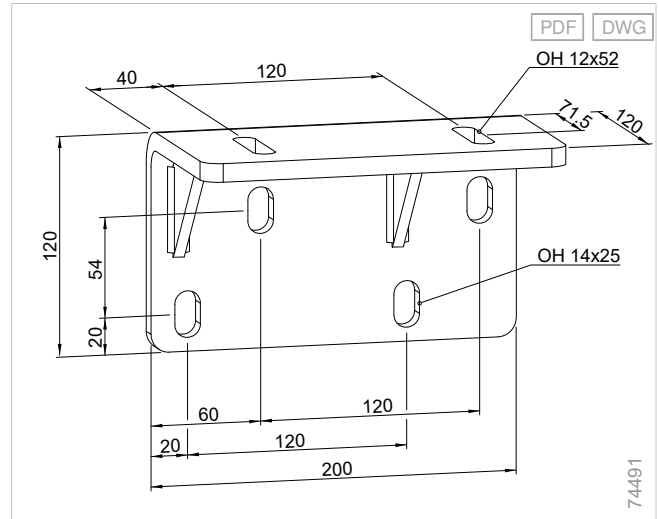

L60/L70, internal base plate

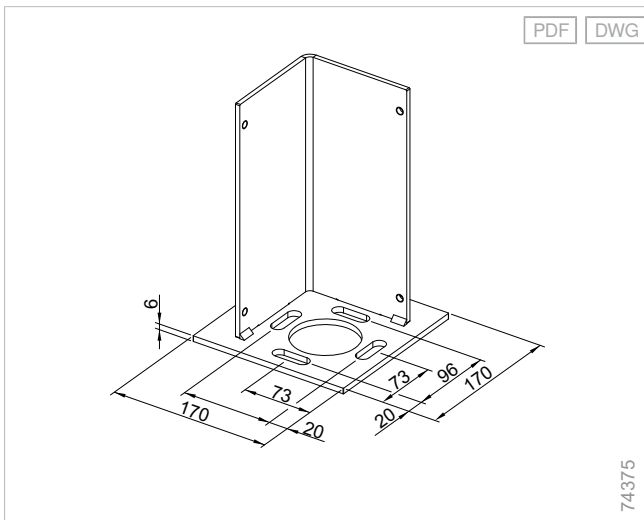

L60/L70, wall console

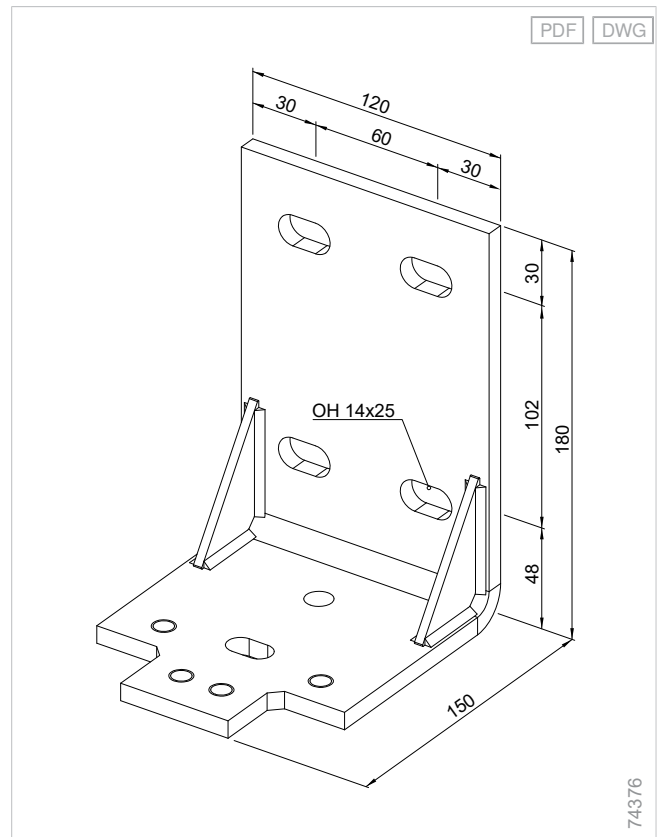

L60/L70, base plate corner installation

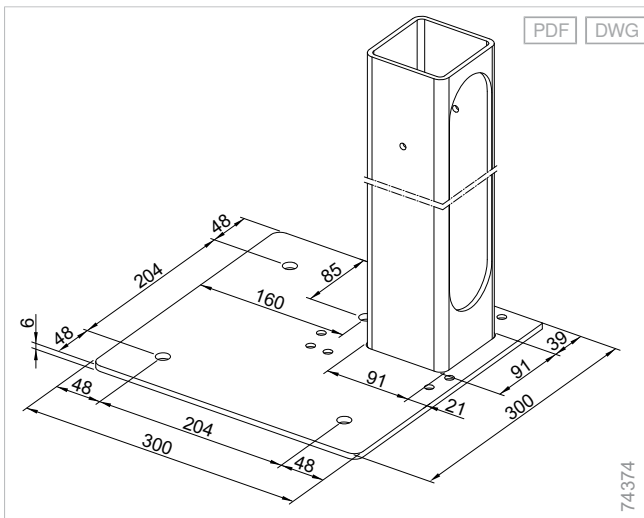

L70, length compensation plates, electrical distribution, crossbeam a

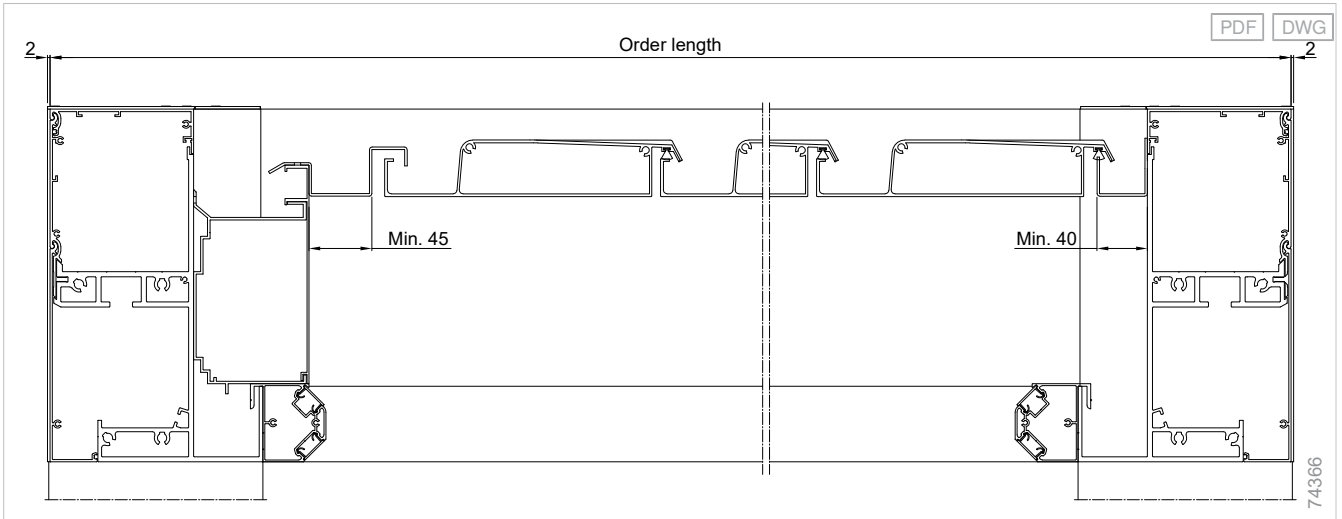

L70, length compensation plates, electrical distribution, crossbeam c

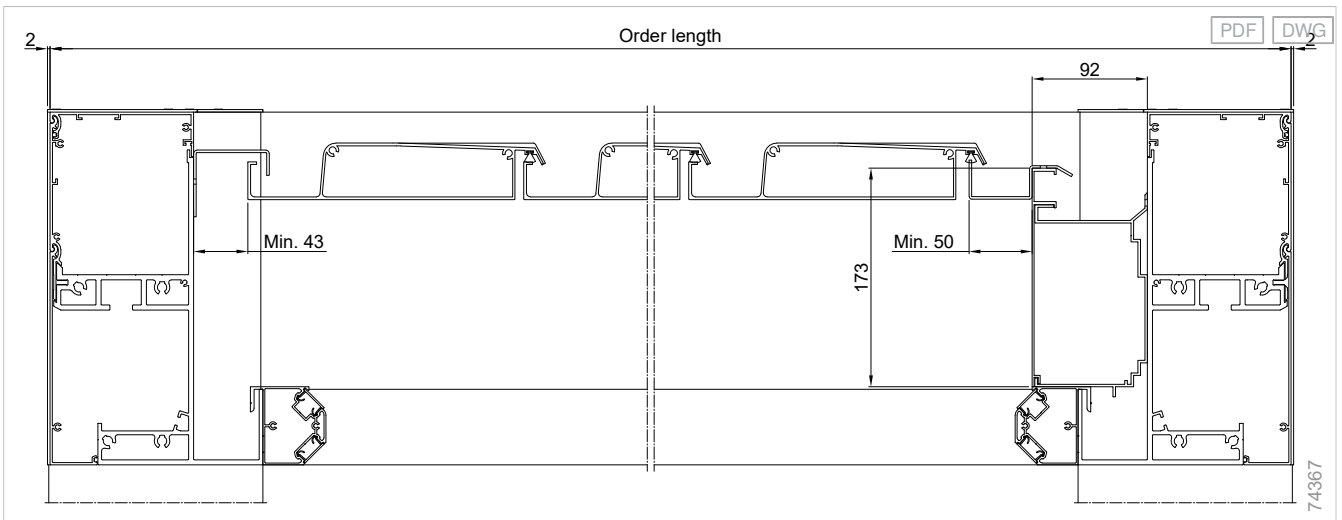

L70, slat inclination

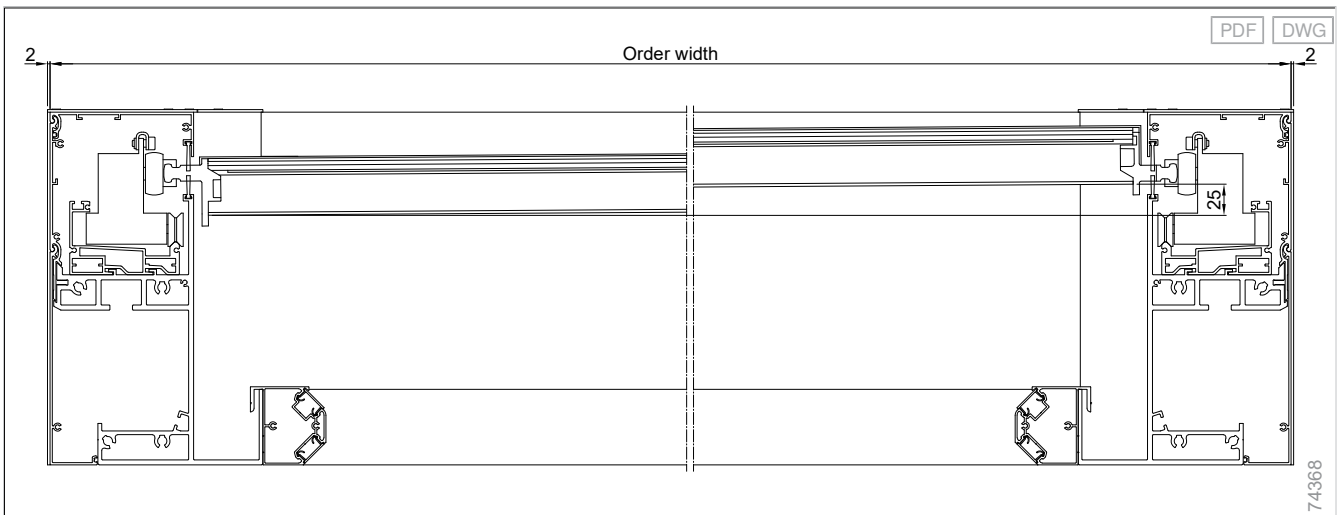

Planning

Slat roofs
Lamaxa

Glass roofs
Lamaxa

Fabric roofs
Lamaxa

Supplementary
accessories

Drive
variants

Standards

L60/L70, wall console, lateral trim panel

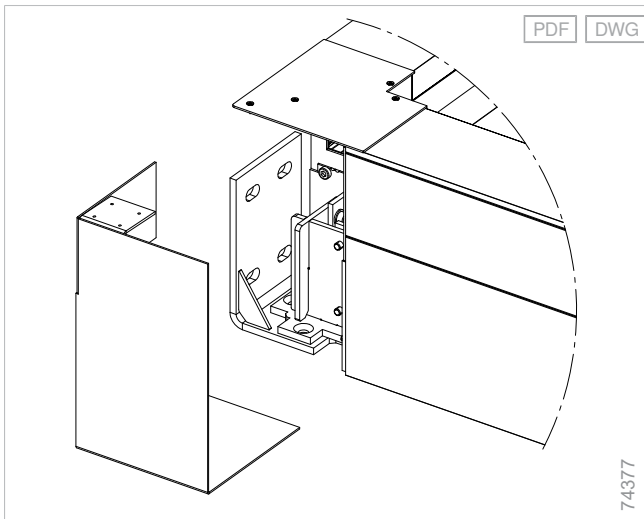

Wall connection profile with small rain hood - L50/L60/L70

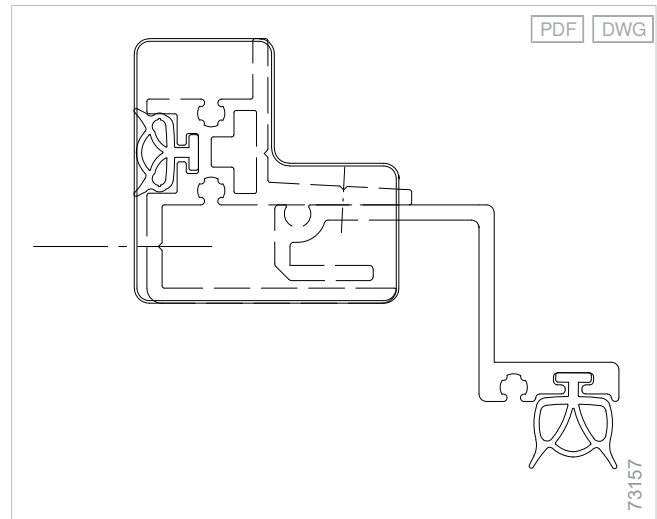

L60/L70, wall console, lateral facing, inner angle

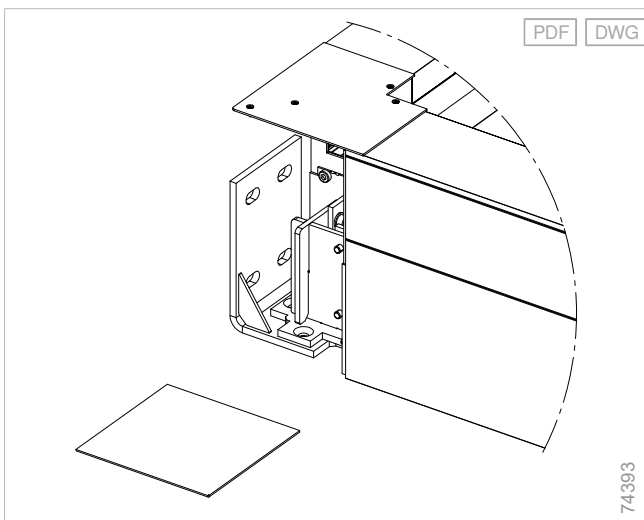

Additional product information

Pole installation options

Ground installation with frost-proof on-site foundation, see slat roof guidelines (IVRSA).

Mounting examples

L60/L70, floor recess, separation cut

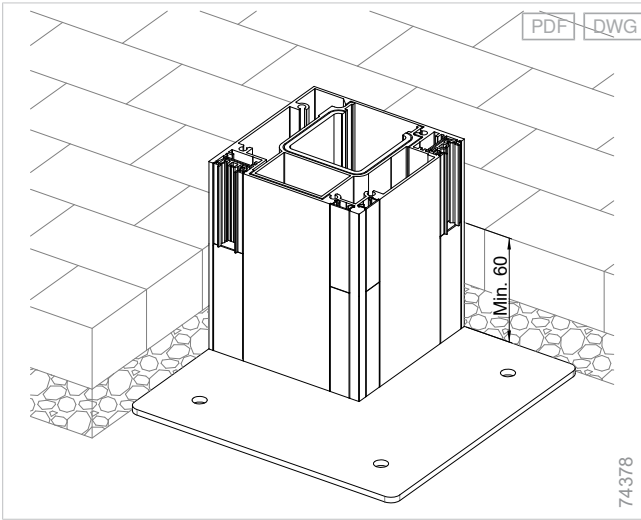

L60/L70, base plate corner installation

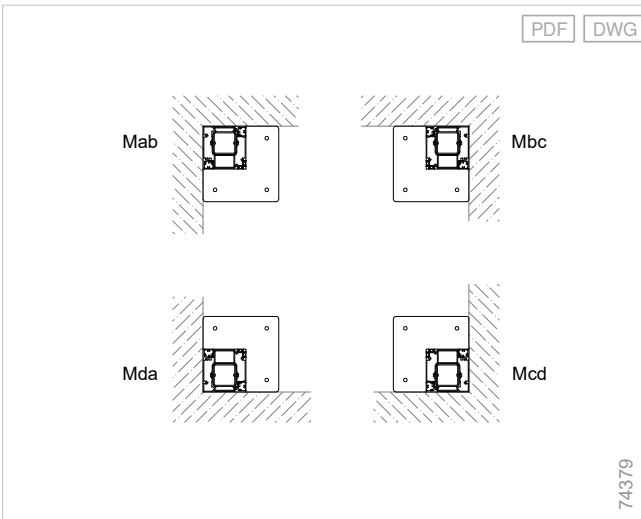

L60/L70, shim plate

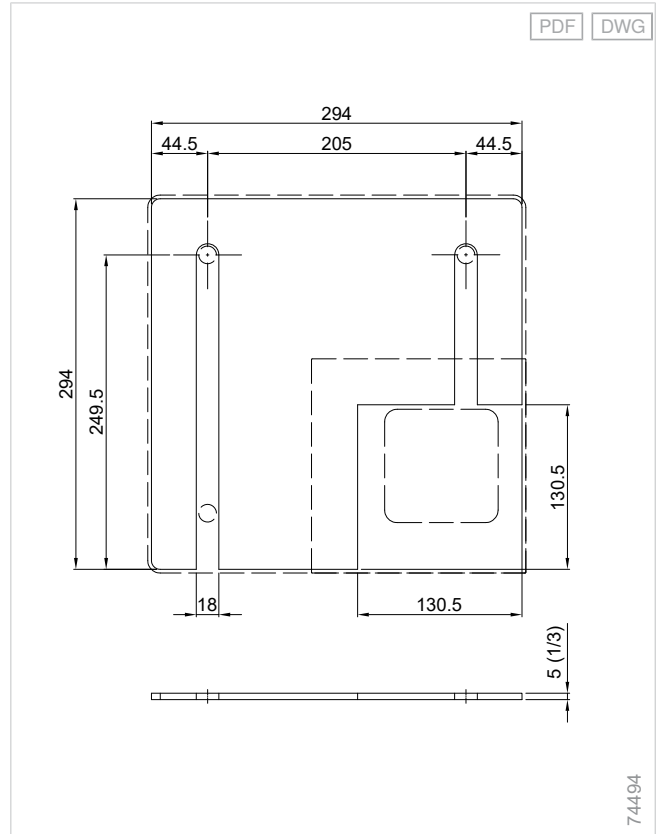

L60/L70, quarter shim plate

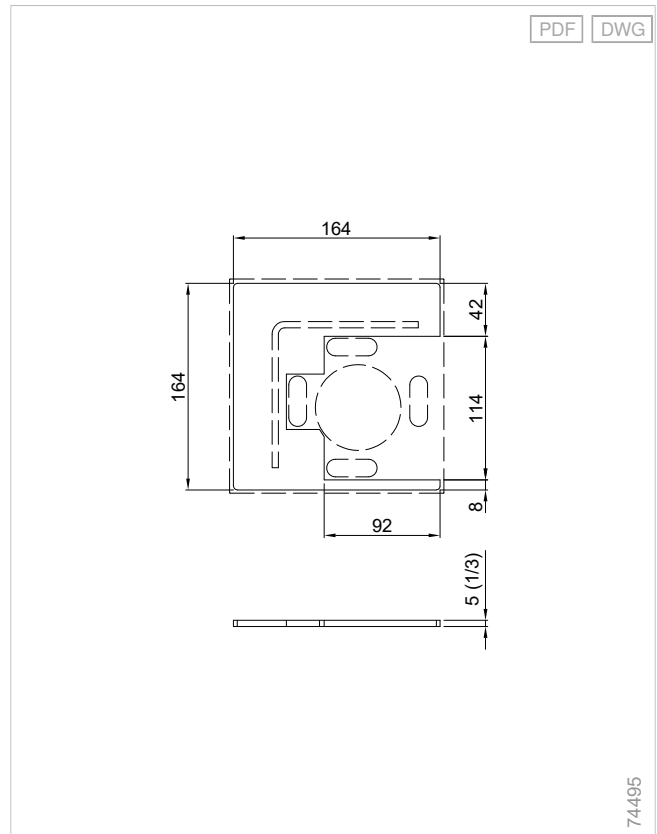

Planning

Slat roofs
Lamaxa

Glass roofs
Lamaxa

Fabric roofs
Lamaxa

Supplementary
accessories

Drive
variants

Standards

L60/L70, wall connection

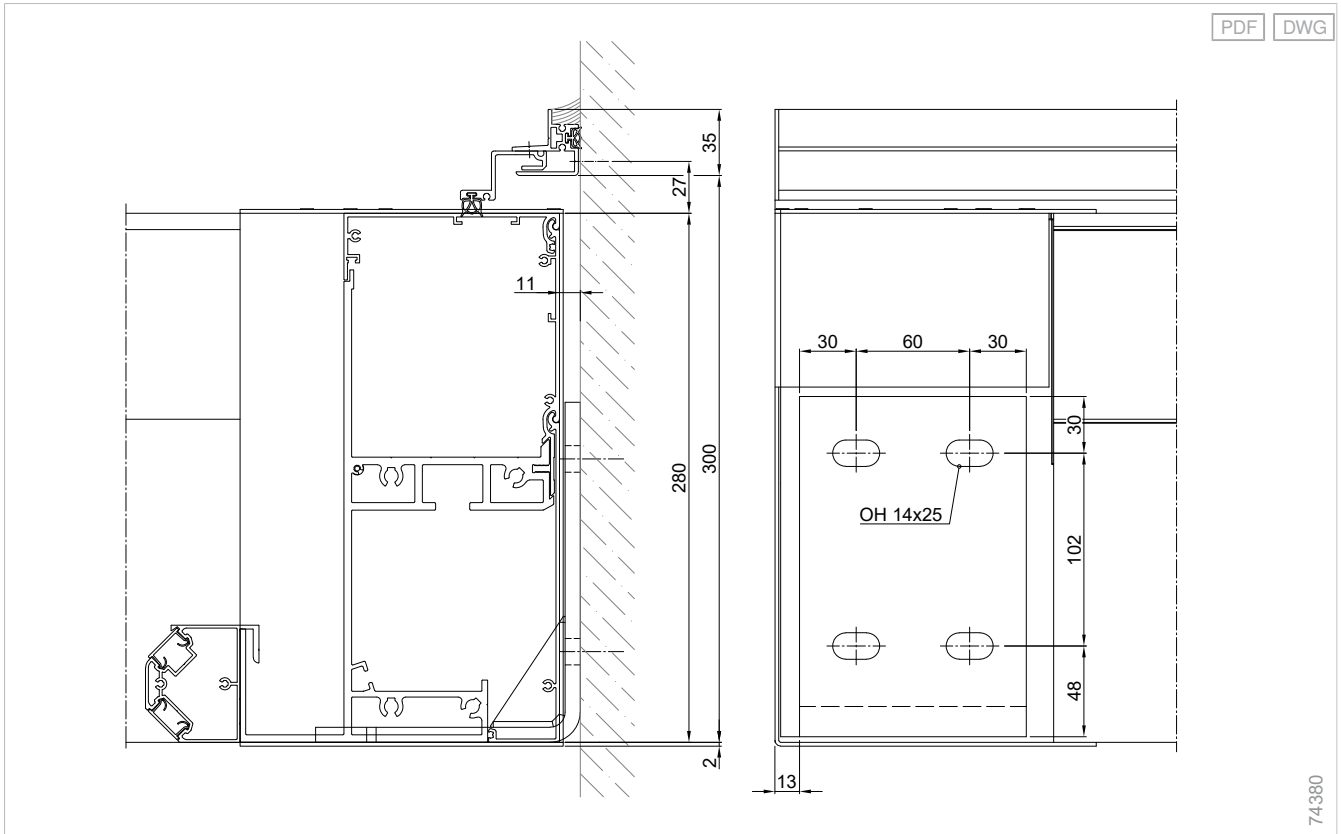

L60/L70, awning with easyZIP guidance, refurbishment

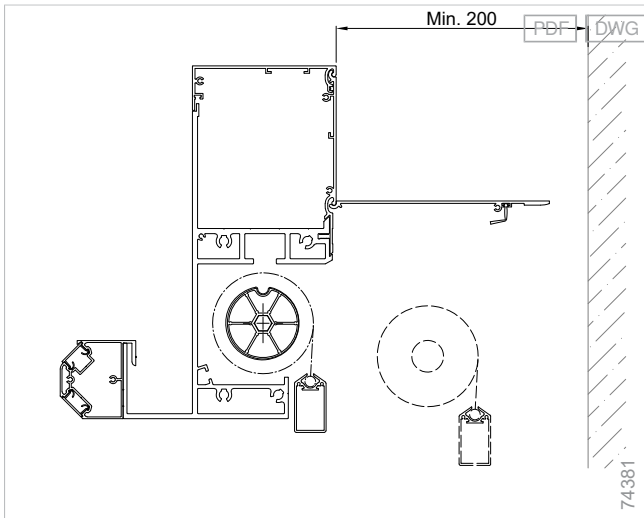

L60/L70, Design radiant heater

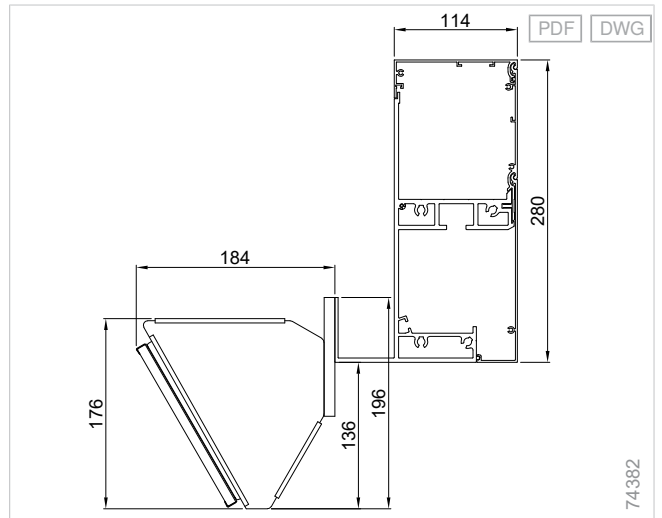

L60/L70, Free-installation with offset wall console

PDF DWG

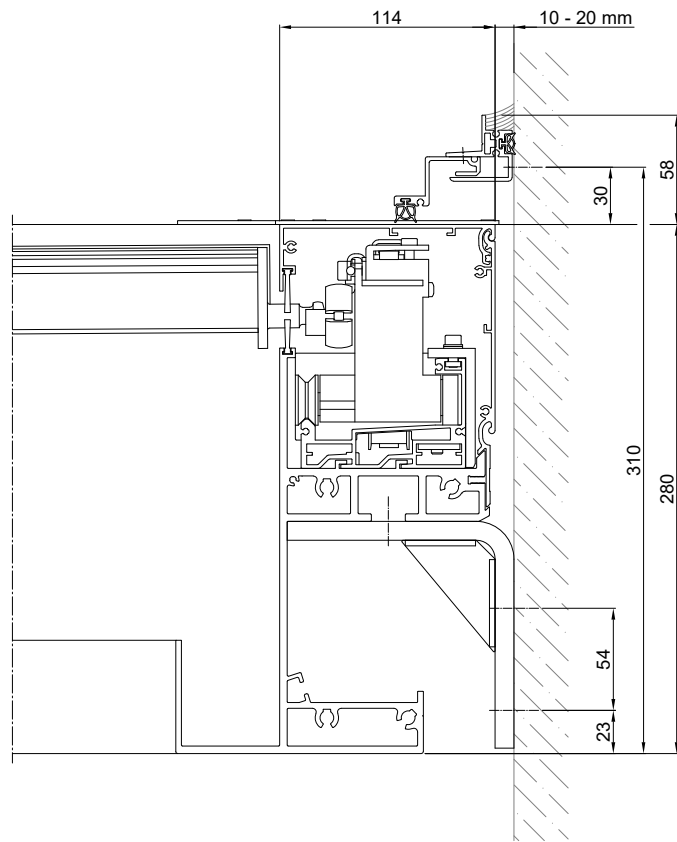

74490

In the case of the Free installation version with offset wall console, the beam cover is omitted, creating a gap between the beam and the installation point. Angle bracket or cover on request.

Planning

Slat roofs
Lamaxa

Glass roofs
Lamaxa

Fabric roofs
Lamaxa

Supplementary
accessories

Drive
variants

Standards



Roof systems

Slat roofs Lamaxa L70 Line

Elegantly connected

Shading of very large areas: With a central pole, several units can be elegantly lined up along the long as well as the short side.

Combinable

Double the flexibility: Combinations of the L60 (tiltable slats) and L70 (tiltable and movable slats) make individual solutions a possibility.

Year-round use

Protection in all weather: Depending on the type, the incidence of light can be adjusted to several levels with the tilting and moving slats – from a fully unobstructed view of the sky all the way to a complete closure of the slat roof.

Construction limit values

Maximum order width	9000 mm
Maximum order length	12000 mm
Maximum order area	54 m ²

Order here

myWAREMA

[Art.-Nr. 2072962](#)

WAREMA tools

[Sun Shading Planner](#)

[+ see "Navigating the document", Page 5](#)

Components

Lamaxa Line - L60/L70

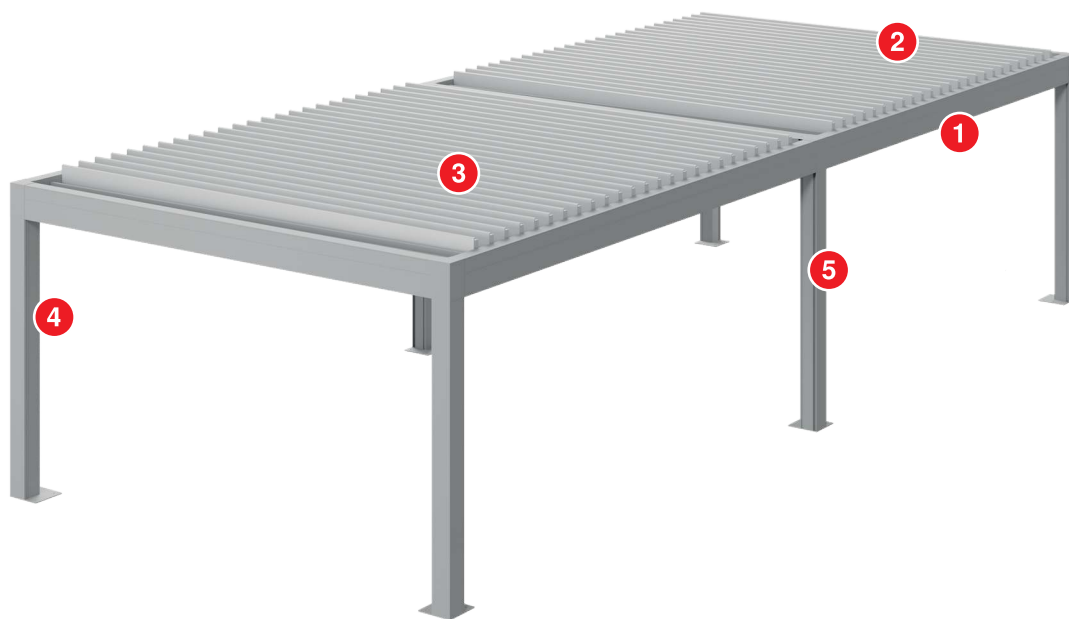

- 1 Crossbeam with tilting mechanics
- 2 Crossbeam with motor
- 3 Slats

- 4 Pole
- 5 Middle pole

Lamaxa Line - L60/L70

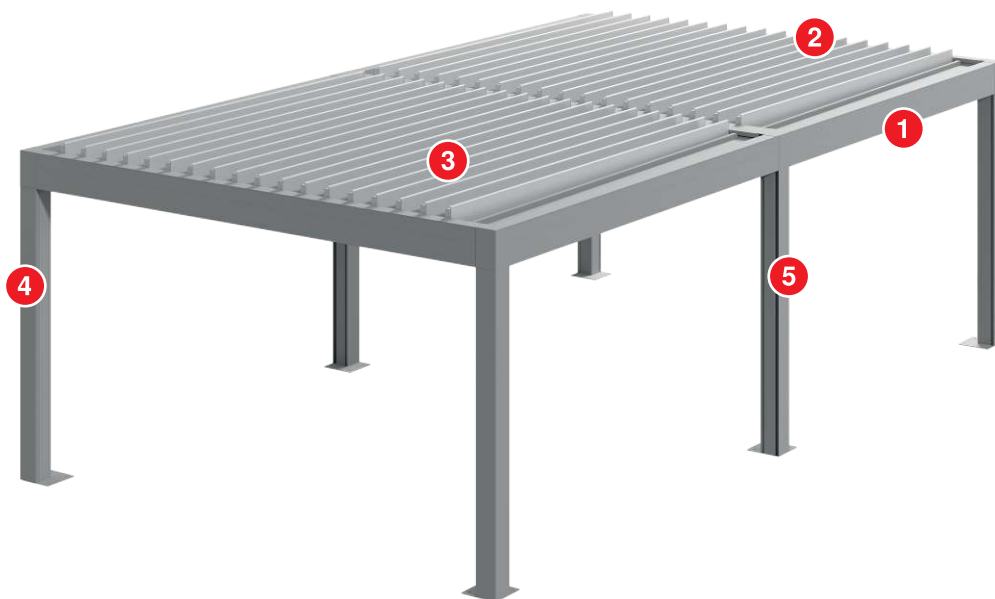

- 1 Crossbeam with motor
- 2 Crossbeam with tilting mechanics
- 3 Slats

- 4 Pole
- 5 Middle pole

Planning

Slat roofs
Lamaxa

Glass roofs
Lamaxa

Fabric roofs
Lamaxa

Supplementary
accessories

Drive
variants

Standards

Slat

Slat - L70

Material	Aluminium, extruded
Surface	Powder-coated
Width	235 mm
Height	45 mm
Swivelling range	0 - 135 °

Pole

Pole - L60/L70

Material	Aluminium, extruded
Surface	Powder-coated
Width	170 mm
Height	170 mm

Installation options:

- Ground installation with frost-proof, on-site foundation.
- The grout for filling the clearance is not included in the scope of delivery when threaded rods are used.

Floor recess and separation cut:

- For a floor recess, we recommend the use of a separation cut in the inspection parts to allow for inspection without dismantling the floor.
- If the floor recess does not have a separation cut, the easyZIP guidance inlays and the integrated LED strips reach the bottom edge of the pole profile.
- Floor recesses with a separation cut must be at least 60 mm.

Centre pole - L60/L70 Line

Material	Aluminium, extruded
Surface	Powder-coated
Width	170 mm
Height	170 mm

Installation options:

- Ground installation with frost-proof, on-site foundation.
- The grout for filling the clearance is not included in the scope of delivery when threaded rods are used.

Floor recess and separation cut:

For a floor recess, we recommend the use of a separation cut in the inspection parts to allow for inspection without dismantling the floor. If the floor recess does not have a separation cut, the easyZIP guidance inlays and the integrated LED strips reach the bottom edge of the pole profile.

Pole, optional

Pole guide rails - L60/L70

Material	Aluminium, extruded
Surface	Powder-coated
Width	170 mm
Height	170 mm

If an easyZIP awning is installed in a field in which a wall console is installed, a separate pole is required below the wall console. Inward or outward drainage through guide rail poles possible. Only corner base plate possible.

Base plate

Base plate - corner installation L60/L70

Material	Galvanised steel
Surface	Plain
Optional surface	Powder-coated
Width	300 mm
Height	300 mm

Base plate - internal L60/L70

Material	Galvanised steel
Surface	Plain
Optional surface	Powder-coated
Width	170 mm
Height	170 mm

Since the material thickness is generally visible, the internal base plate should be coated if there is no floor recess.

Crossbeam

Crossbeam - L60/L70

Material	Aluminium, extruded
Surface	Powder-coated
Width	169 mm
Height	280 mm

Electrical distribution on the crossbeam

Material	Aluminium, extruded
Surface	Powder-coated
Width	91,5 mm
Height	174 mm

Drainage

Drainage in pole - L60/L70 Line

- Drainage through drainpipe in pole
- If each roof crown is smaller than 16 m², one drainage point per roof is sufficient to comply with an average rainfall event $r_{5/2} = 350 \text{ l/(s ha)}$. If a roof crown is $\geq 16 \text{ m}^2$, it must be equipped with a second drainage point.
- To withstand average rainfall, three drainage points are sufficient for a total area of up to 54 m² if each roof is equipped with a separate drainage point plus a third common drainage point at the centre pole.

Position of drainage outlet:

- Possible on every pole
- Drainage and electronics/connecting lines must always be installed in separate poles.
- On the outsides of the poles or downward
- Min. height: 150 mm/height: 40 mm (for internal base plates)
- Max. height: 250 mm below the headroom

Note: Downward drainage through base plate:

When planning and measuring, please note that the concrete foundation must be very precisely manufactured if downward drainage through the base plate is required!

Wall connection profile, optional

Wall connection profile with small rain hood

Material	Aluminium, extruded
Surface	Powder-coated
Width	54 - 65 mm
Height	48 mm
Dimensions, notes	The adjustment range in the depth between rain hood and wall connection profile is up to 11 mm.

The on-site sealing is the responsibility of the specialist partner; if necessary, the commissioning of a plumbing company is recommended.

Field of application:

- Terrea K50
- Terrea K70
- Perea P20 (up to an angle of 10°)
- Lamaxa L50/L60/L70

Console, optional

Wall console - Lamaxa L60/L70

Material	Galvanised steel
Surface	Powder-coated
Width	120 mm
Height	180 mm
Depth	140 mm

- Use in corner as pole replacement.
- A maximum of two poles can be replaced by wall consoles.
- For a concrete mounting substructure; adapter plates are required for other substructures.

- The wall console protrudes 11 mm beyond the order width and order length. This results in a gap of 11 mm between the crossbeam and the wall.
- For inner angle wall consoles, the lateral corner area is not covered by profiles.

Offset wall console - Lamaxa L60/L70

Material	Aluminium, extruded
Width	200 mm
Height	120 mm
Depth	120 mm

- For attachment to Tb and/or Td.
- Use in corner as pole replacement or as Free installation.
- A maximum of 4 poles can be replaced by offset wall consoles.
- For a concrete mounting substructure; adapter plates are required for other substructures.
- In the case of the Free installation version with offset wall console, the beam cover is omitted, creating a gap between the beam and the installation point. Angle bracket or cover on request.

Drive variants

- Motor

Motor

- WMS-LP (WMS)

⊕ see "Drive variants", Page 201

Colours

- WAREMA Colour World, Highlight category, fine texture surface quality
- WAREMA Colour World, Variation category, fine texture surface quality

Colours, optional:

- WAREMA Colour World

⊕ see "Colours and finishes", Page 10

Notes

Notes on product configuration

Series-mounted units:

- If the distance between the facade and the centre pole is ≥ 300 mm, integrated awnings with easyZIP guidance can be installed in the fields adjacent to the centre pole. If the distance is < 300 mm (minimum distance 10 mm), no easyZIP awnings can be installed in the adjacent fields (retrofitting is also not possible).
- Generally, unit coupling (drive coupling) is not possible.
- Flush closures allow two slat roofs to be centrally mounted in-series on one common pole.
- The two slat roofs can overlap either at the order width or order length and have the same closing and extension direction (no counter-rotation).
- The electrical distribution of the respective units is located on the crossbeam. The corresponding connecting line is required in a pole adjacent to the electrical distribution.
- If both electrical distributions are positioned on the overlapping crossbeams, the on-site power supply is possible via a centre pole.
- A combination of L60 and L70 is possible in both joint directions.
- It is possible to integrate easyZIP or LEDs into any side of the pole (but not below the double crossbeam in the joint area).
- RGB lighting of both units can be learned in to an RGB hand-held transmitter.
- One drainage point per 16 m^2 of roof area is sufficient per unit. Three drainage points are sufficient for a total area of up to 54 m^2 if each roof is equipped with a separate drainage point plus a third common drainage point at the centre pole.

Notes on installation

Limit position learning:

The WAREMA Smart programming cable is required to set the motor limit positions.

Notes on operation

To ensure convenient and fast operation of the slat roof, we recommend WMS WebControl pro (control via smartphone, tablet, etc.) and WMS Weather station plus in order to use the control modes (e.g. sun control).

Supplementary accessories

- Design radiant heater
- Lamaxa lighting
- Integrated awnings with easyZIP guidance
- Additional pole - L60/L70
- Glass sliding system SL20e
- Sliding shutters - L50/L60/L70
- Power socket

➕ see "Supplementary accessories", Page 143

Construction limit values

Configuration variants	Minimum order width	Maximum order width	Minimum order length	Maximum order length	Maximum order area	Minimum headroom	Maximum headroom
Slat							
Slat - L70	2500 mm	9000 mm	2000 mm	12000 mm	54 m ²	2350 mm	2700 mm

Dimension determination

The headroom of each pole can be ordered individually (e.g. in case of a sloping finished floor).

L70, Lamaxa Line

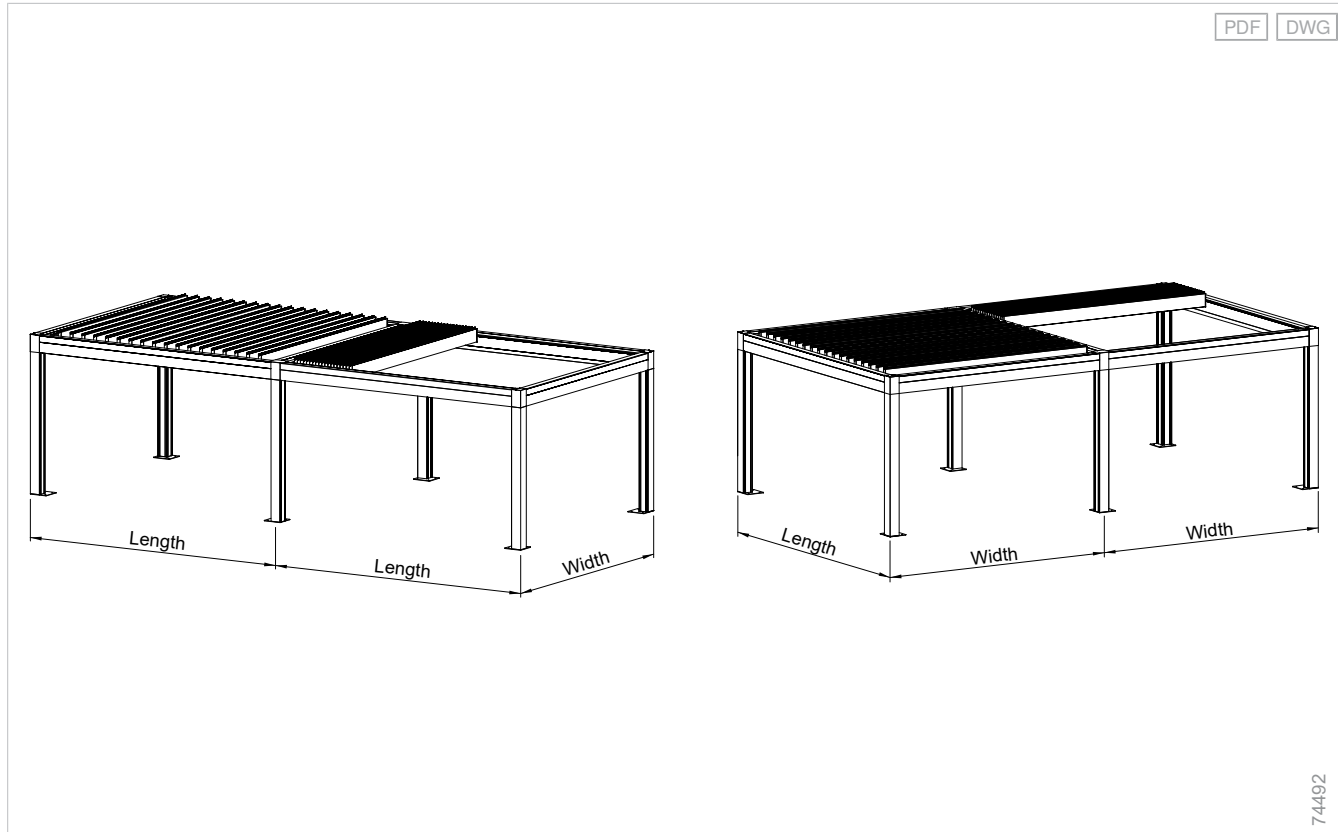

74492

Top view of the position/connection points - Lamaxa Line L50/L60/L70

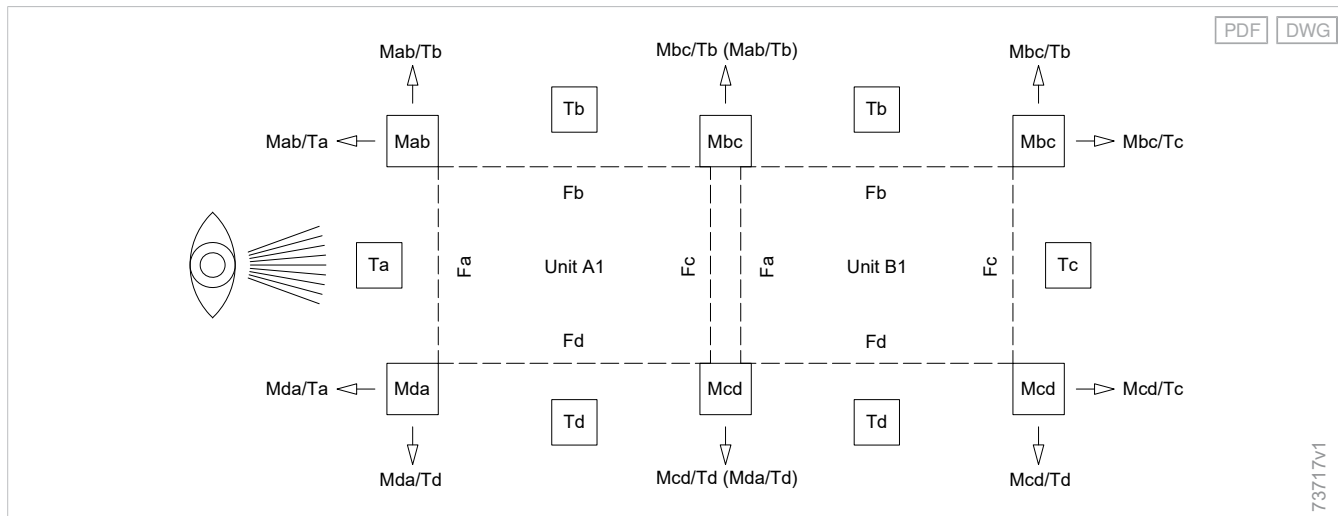

73717v1

- F Field
- M Point of installation (pole or wall connection)
- T Crossbeam

Top view of the position/connection points - Lamaxa Line L50/L60/L70

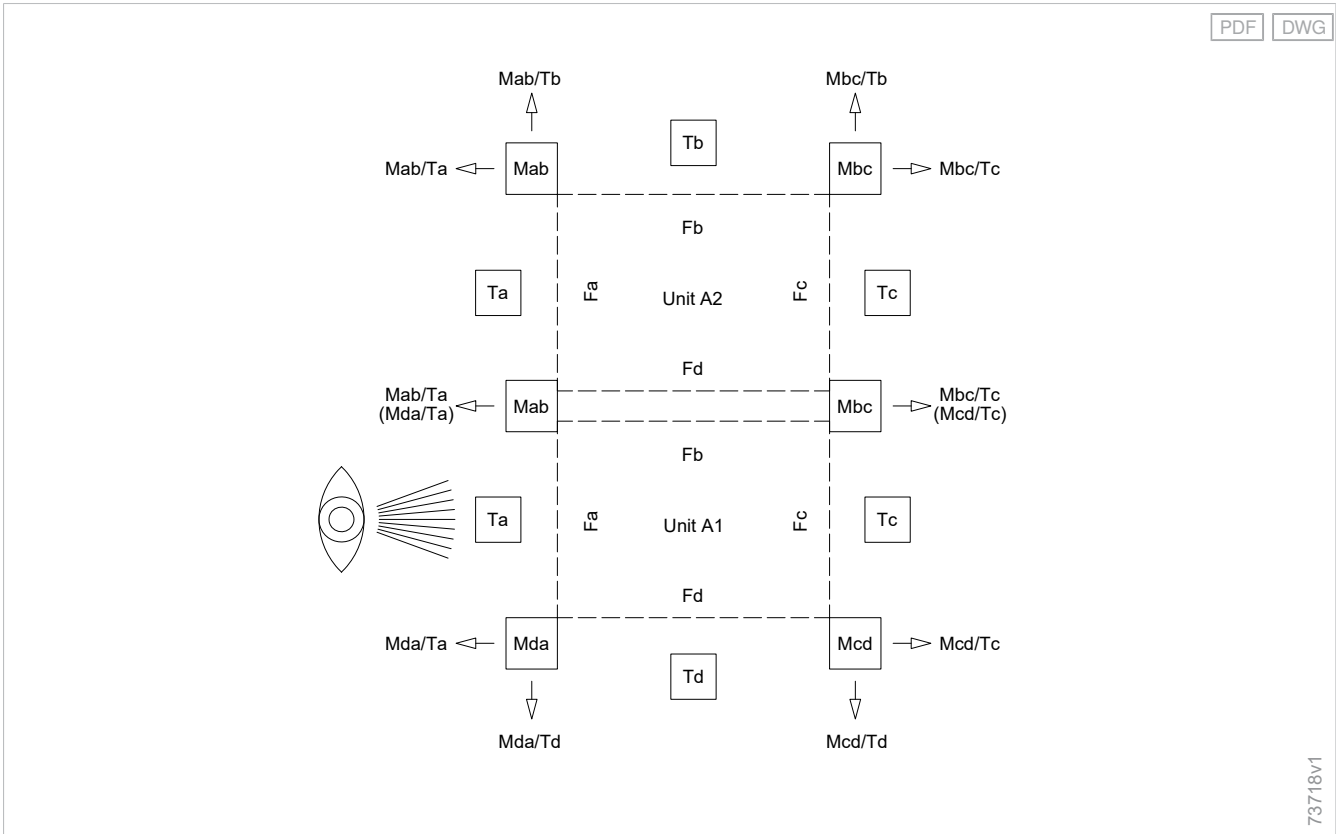

- F Field
- M Point of installation (pole or wall connection)
- T Crossbeam

L60/L70 Line, wall connection, wall console

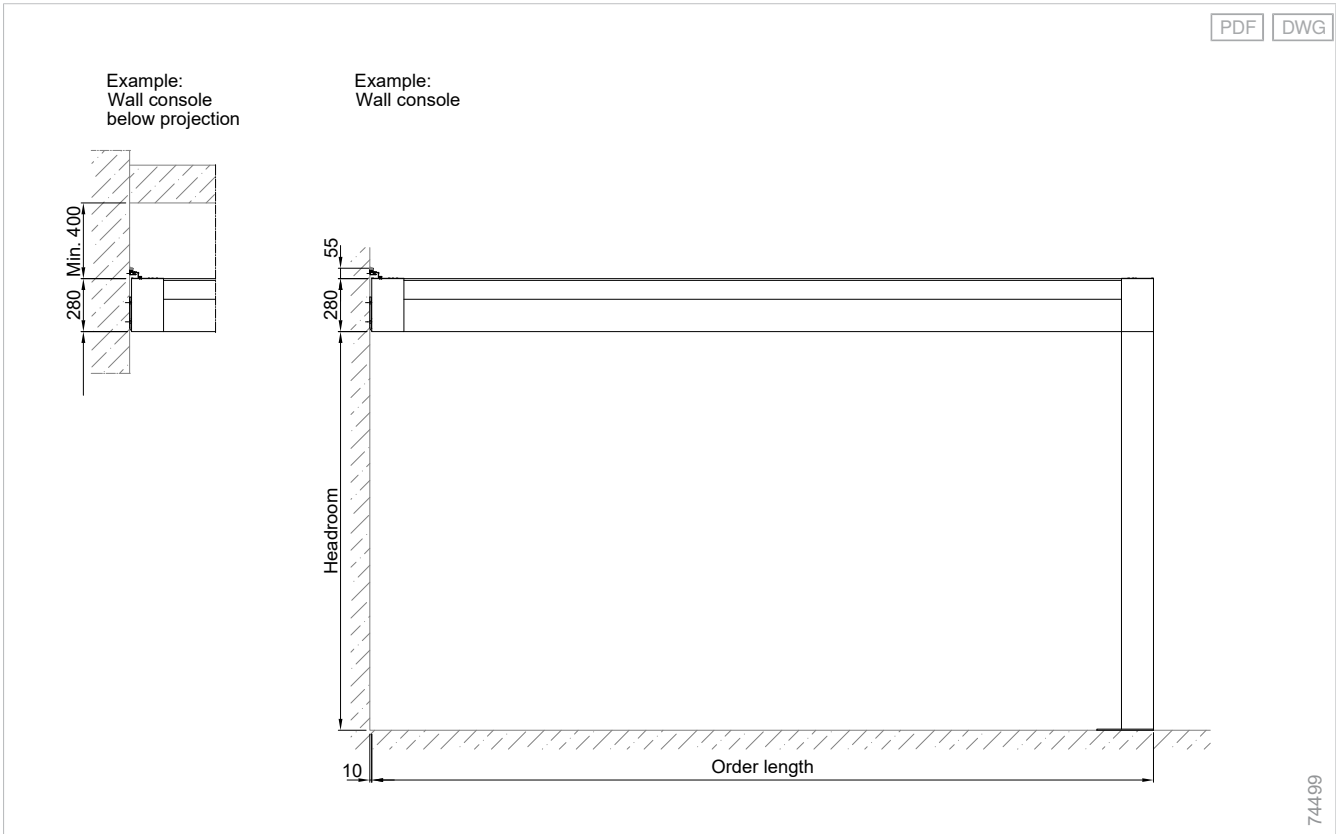

Quantity determination

Number of slats

Order length	Number of slats	Stack length
2000 mm	7	566 mm
2178 mm	8	582 mm
2398 mm	9	640 mm
2618 mm	10	698 mm
2838 mm	11	756 mm
3058 mm	12	814 mm
3278 mm	13	872 mm
3498 mm	14	930 mm
3718 mm	15	988 mm
3938 mm	16	1046 mm
4158 mm	17	1104 mm
4378 mm	18	1162 mm
4598 mm	19	1220 mm
4818 mm	20	1278 mm
5038 mm	21	1336 mm
5258 mm	22	1394 mm
5478 mm	23	1452 mm
5698 mm	24	1510 mm
5918 mm	25	1568 mm

Order length:

- The order length in the table is the dimension with the smallest possible length equalization plates and hence corresponds to the optimum order dimension (except order length 2000 mm).

Stack length:

- The stack length refers to electrical distribution on the crossbeam in field c.
- If the electrical distribution is implemented on the crossbeam in field a, the stack length increases by 105 mm.

Optimum order length for Lamaxa L60/L70 Line = roof crown

Details

L70, slat inclination

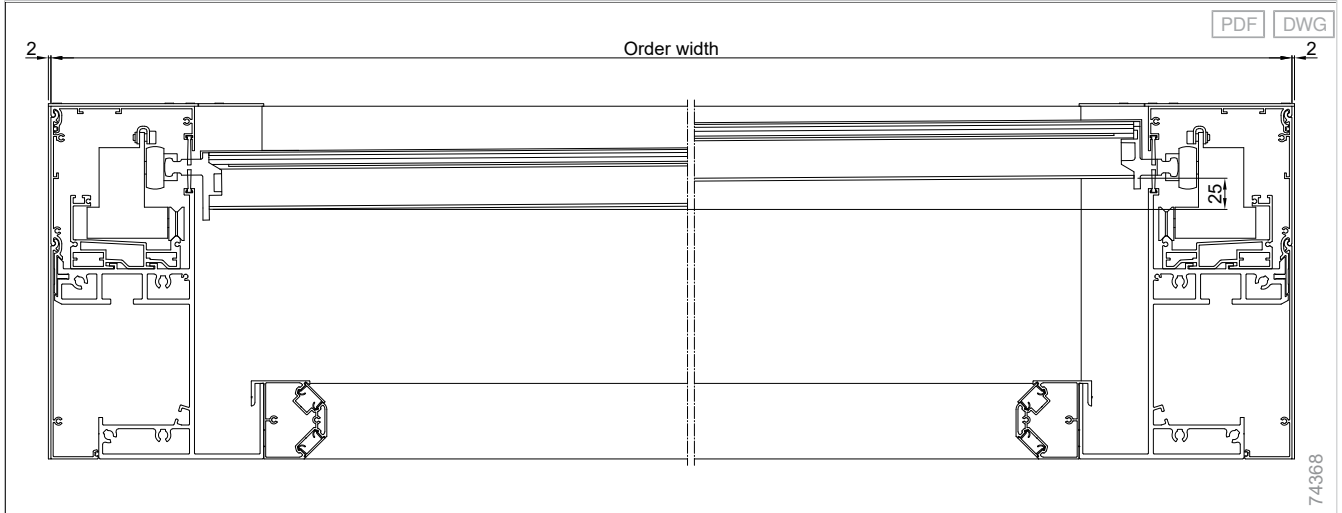

L70 Line, joint order width

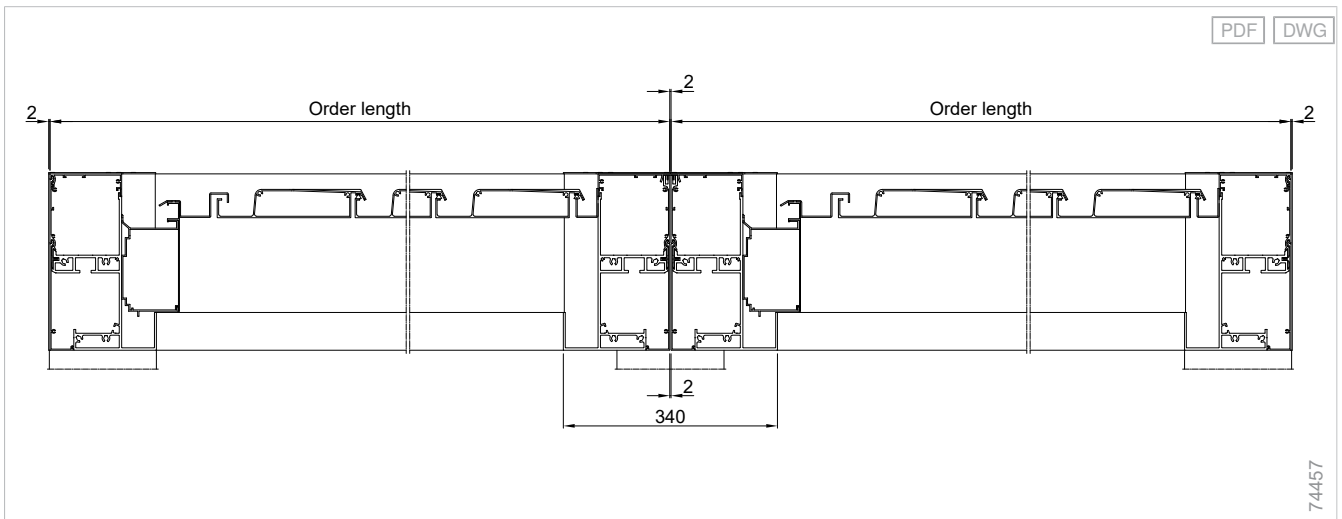

L70 Line, joint order length

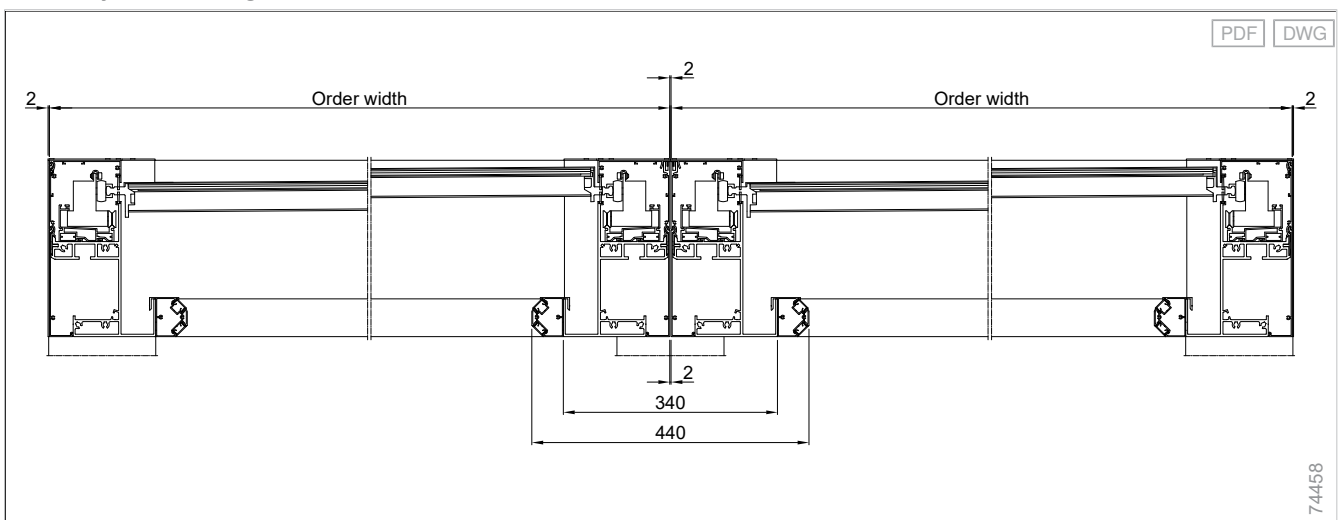

L70, length compensation plates, electrical distribution, crossbeam a

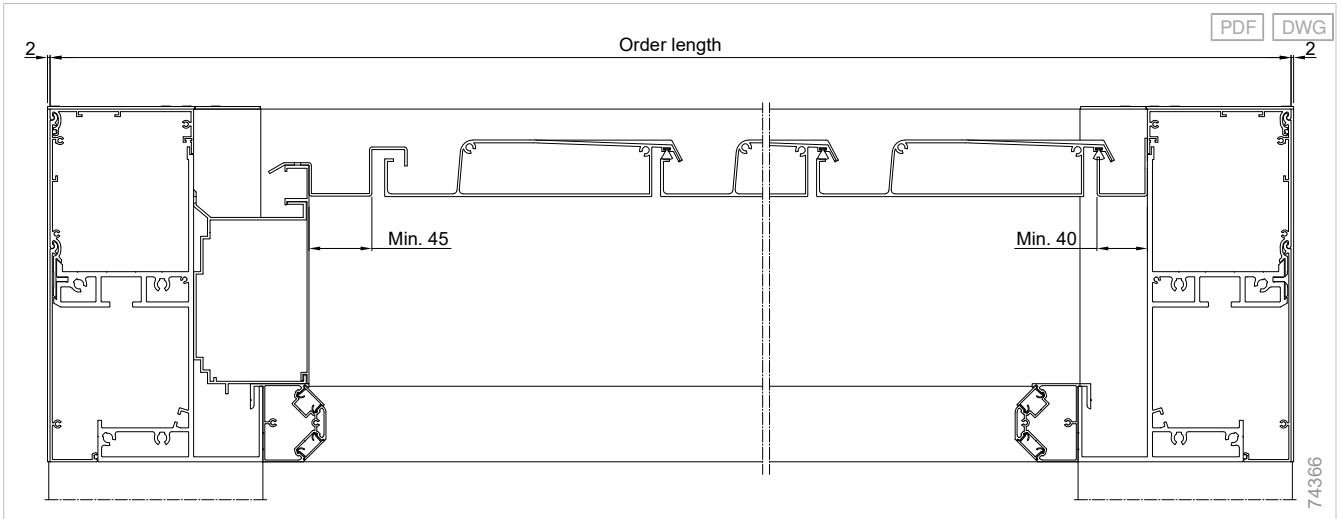

L70, length compensation plates, electrical distribution, crossbeam c

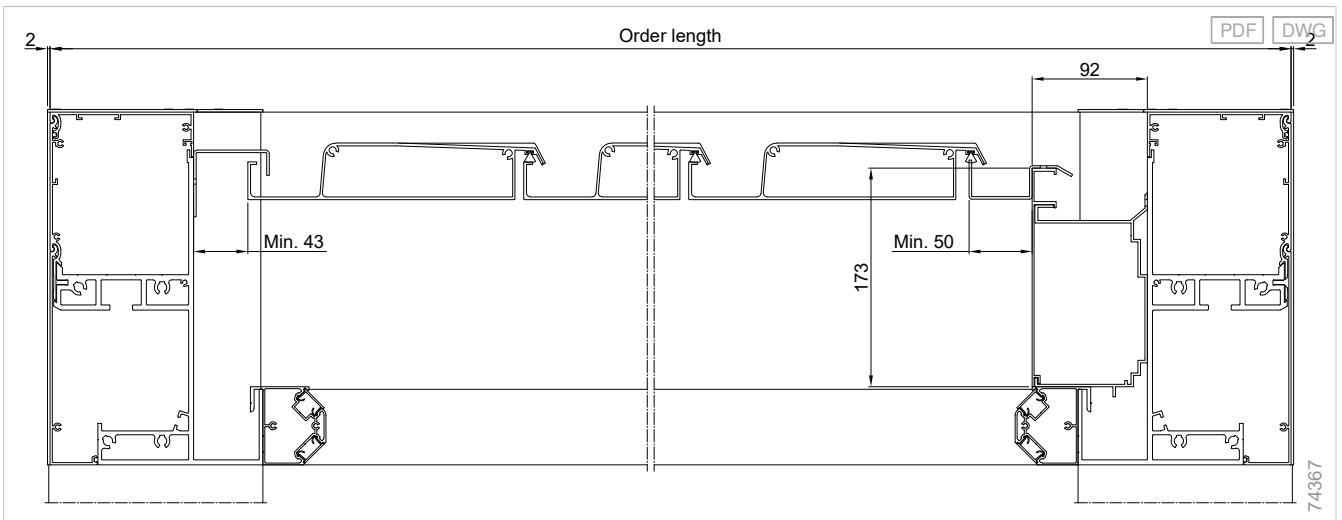

Planning

Slat roofs
Lamaxa

Glass roofs
Lamaxa

Fabric roofs
Lamaxa

Supplementary
accessories

Drive
variants

Standards

L60/L70, shim plate

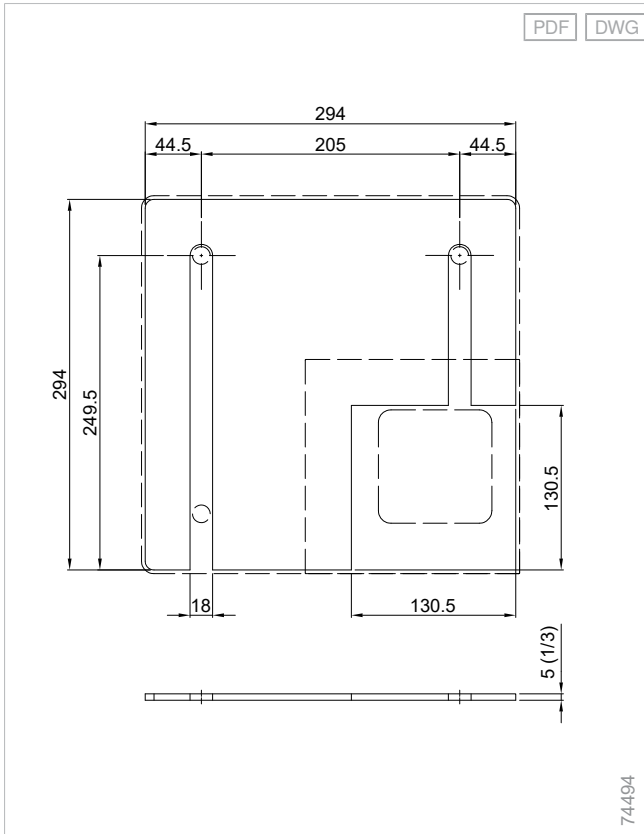

L60/L70, quarter shim plate

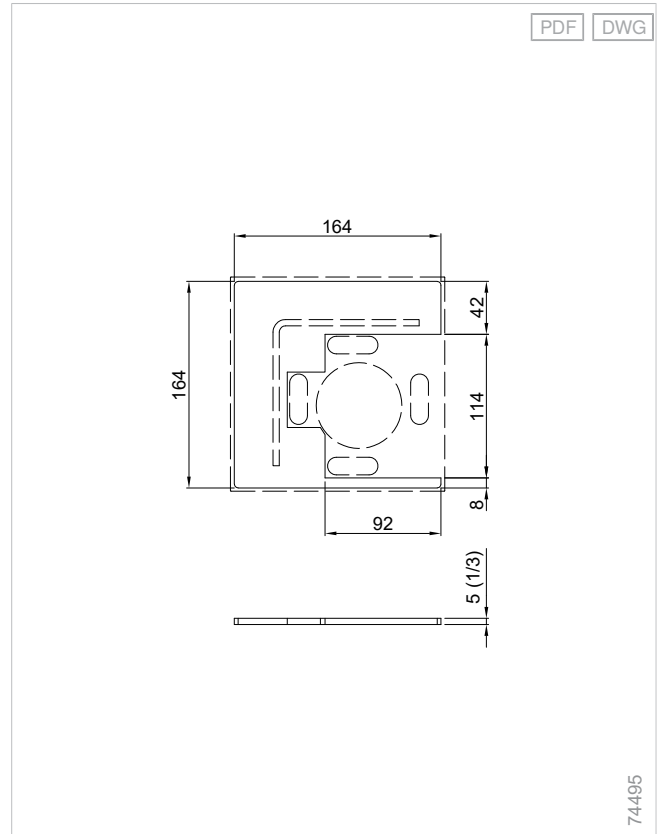

Additional product information

Pole installation options

Ground installation with frost-proof on-site foundation, see slat roof guidelines (IVRSA).

Mounting examples

Joint order width - Lamaxa Line L70

PDF DWG

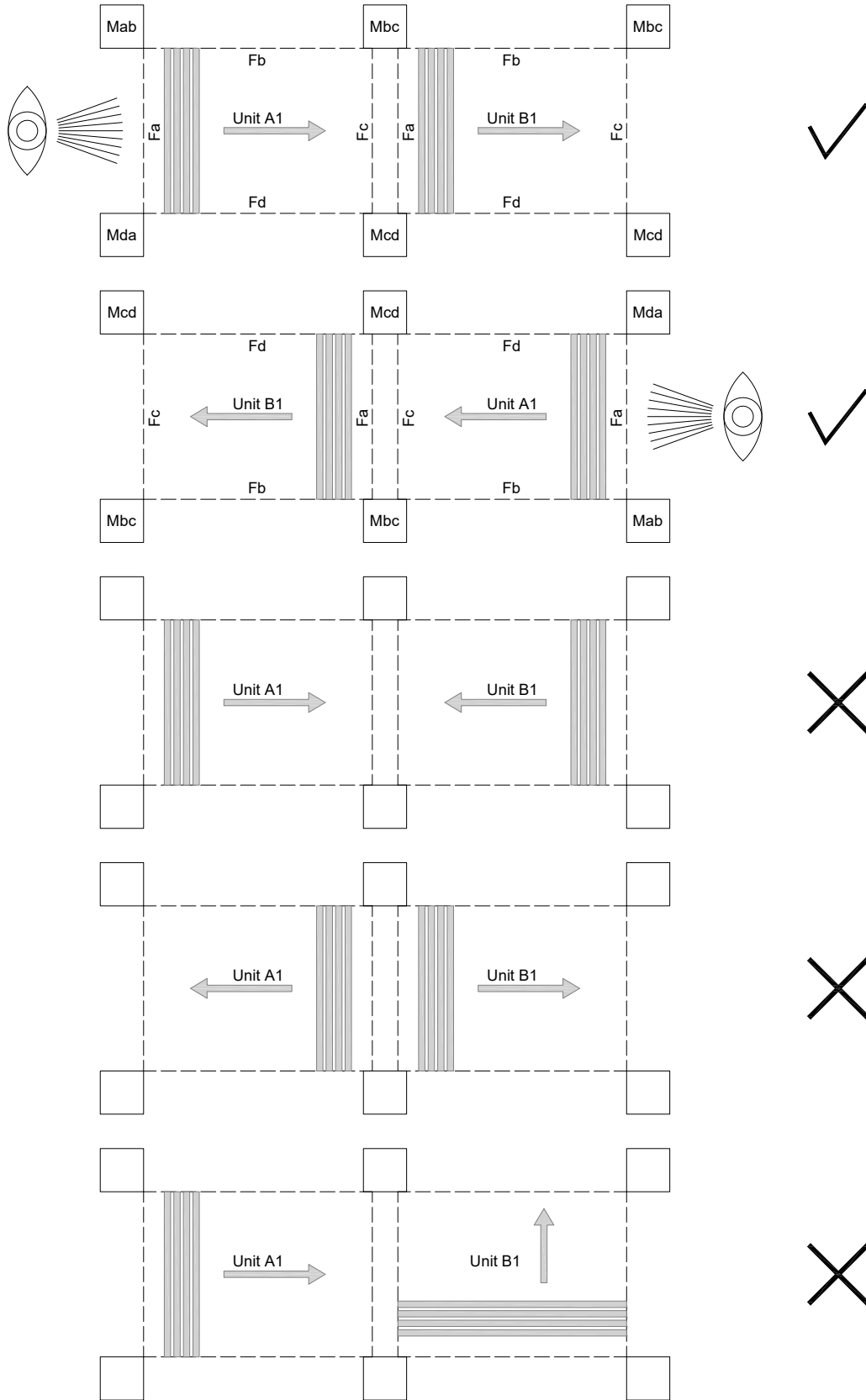

Planning

Slat roofs Lamaxa

Glass roofs Lamaxa

Fabric roofs Lamaxa

Supplementary accessories

Drive variants

Standards

73278v2

P Position

Both units of a Lamaxa Line always have the same closing or extension direction. With joint order width, the unit A1 (Fc) is joined to unit B1 (Fa). With joint order length, the unit A1 (Fb) is joined to unit A2 (Fd). Counter-rotation is therefore not possible. The slats extend in the direction of Fc on an L70. On an L60 and L70, the slats close in the direction of Fc (closing direction).

Joint order length - Lamaxa Line L70

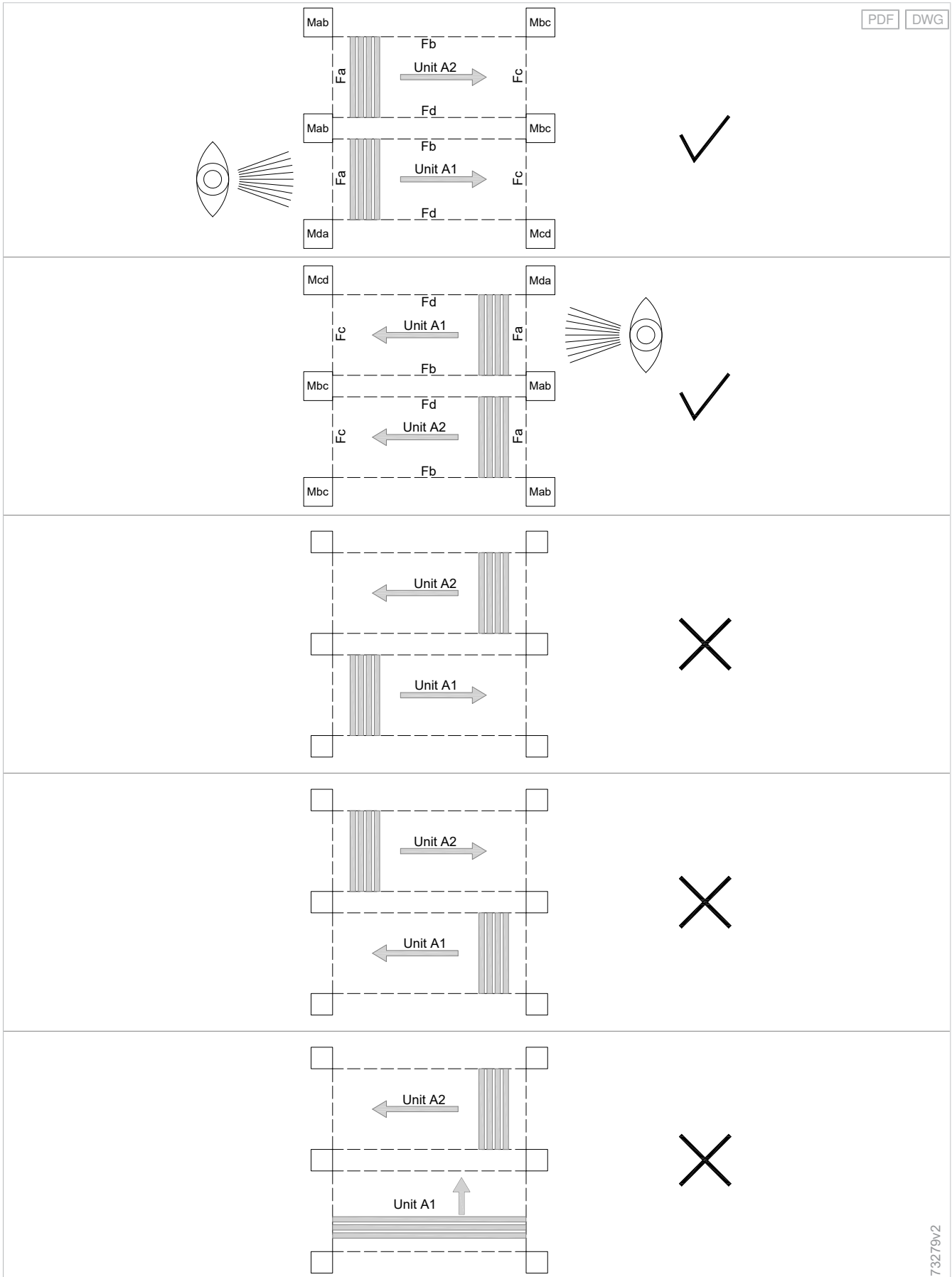

73279v2

P Position

Both units of a Lamaxa Line always have the same closing or extension direction. With joint order width, the unit A1 (Fc) is joined to unit B1 (Fa). With joint order length, the unit A1 (Fb) is joined to unit A2 (Fd). Counter-rotation is therefore not possible. The slats extend in the direction of Fc on an L70. On an L60 and L70, the slats close in the direction of Fc (closing direction).



Roof systems

Slat roofs Lamaxa L60

Year-round use

Protection in all weather: Depending on the type, the incidence of light can be adjusted to various levels with the pivotable slats – all the way to a complete, weather-proof closure of the slat roof.

Dry

Dryness guaranteed: Controlled drainage through integrated rain gutters and drainage in the pole.

Customisable

Can be individually equipped according to personal preference with diverse, optional extras suitable for retrofitting such as integrated LED and RGB lighting, integrated awnings with easyZIP guidance, sash frames or radiant heaters.

Construction limit values

Maximum order width	4750 mm
Maximum order length	6330 mm
Maximum order area	30 m ²

Order here

myWAREMA

[Art.-Nr. 2056448](#)

WAREMA tools

[Sun Shading Planner](#)

[+ see "Navigating the document", Page 5](#)

Components

Slat roof Lamaxa L60

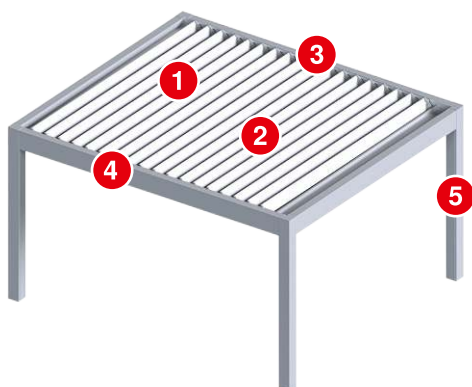

1	Slats	4	Tilting mechanism via push rod
2	Slat with motor	5	Pole
3	Beam		

Slat

Slat - L60

Material	Aluminium, extruded
Surface	Powder-coated
Width	233 mm
Height	57 mm
Swivelling range	0 - 135 °

Pole

Pole - L60/L70

Material	Aluminium, extruded
Surface	Powder-coated
Width	170 mm
Height	170 mm

Installation options:

- Ground installation with frost-proof, on-site foundation.
- The grout for filling the clearance is not included in the scope of delivery when threaded rods are used.

Floor recess and separation cut:

- For a floor recess, we recommend the use of a separation cut in the inspection parts to allow for inspection without dismantling the floor.
- If the floor recess does not have a separation cut, the easyZIP guidance inlays and the integrated LED strips reach the bottom edge of the pole profile.
- Floor recesses with a separation cut must be at least 60 mm.

Pole, optional

Pole guide rails - L60/L70

Material	Aluminium, extruded
Surface	Powder-coated
Width	170 mm
Height	170 mm

If an easyZIP awning is installed in a field in which a wall console is installed, a separate pole is required below the wall console. Inward or outward drainage through guide rail poles possible. Only corner base plate possible.

Base plate

Base plate - corner installation L60/L70

Material	Galvanised steel
Surface	Plain
Optional surface	Powder-coated
Width	300 mm
Height	300 mm

Base plate - internal L60/L70

Material	Galvanised steel
Surface	Plain
Optional surface	Powder-coated
Width	170 mm
Height	170 mm

Since the material thickness is generally visible, the internal base plate should be coated if there is no floor recess.

Crossbeam

Crossbeam - L60/L70

Material	Aluminium, extruded
Surface	Powder-coated
Width	169 mm
Height	280 mm

Electrical distribution on the crossbeam

Material	Aluminium, extruded
Surface	Powder-coated
Width	91,5 mm
Height	174 mm

Drainage

Drainage in pole - L60/L70

- Drainage through drainpipe in pole
- In order to achieve rain class 2 with closed slats, at least one drainage point is required for a unit size smaller than 16 m² and at least two drainage points for a unit size larger than 16 m². If the minimum number of drainage points is not observed, rain class 2 is not achieved.

Position of drainage outlet:

- Possible on every pole
- Drainage and electronics/connecting lines must always be installed in separate poles.
- On the outsides of the poles or downward
- Min. height: 120 mm - 380 mm/height: 40 mm (for internal base plates)
- From 550 mm to 500 mm below the headroom

Note: Downward drainage through base plate:

When planning and measuring, please note that the concrete foundation must be very precisely manufactured

if downward drainage through the base plate is required. The drainage does not sit centrally in the base plate.

Wall connection profile, optional

Wall connection profile with small rain hood

Material	Aluminium, extruded
Surface	Powder-coated
Width	54 - 65 mm
Height	48 mm
Dimensions, notes	The adjustment range in the depth between rain hood and wall connection profile is up to 11 mm.

The on-site sealing is the responsibility of the specialist partner; if necessary, the commissioning of a plumbing company is recommended.

Field of application:

- Terrea K50
- Terrea K70
- Perea P20 (up to an angle of 10°)
- Lamaxa L50/L60/L70

Console, optional

Wall console - Lamaxa L60/L70

Material	Galvanised steel
Surface	Powder-coated
Width	120 mm
Height	180 mm
Depth	140 mm

- Use in corner as pole replacement.
- A maximum of two poles can be replaced by wall consoles.
- For a concrete mounting substructure; adapter plates are required for other substructures.
- The wall console protrudes 11 mm beyond the order width and order length. This results in a gap of 11 mm between the crossbeam and the wall.
- For inner angle wall consoles, the lateral corner area is not covered by profiles.

Offset wall console - Lamaxa L60/L70

Material	Aluminium, extruded
Width	200 mm
Height	120 mm
Depth	120 mm

- For attachment to Tb and/or Td.
- Use in corner as pole replacement or as Free installation.
- A maximum of 4 poles can be replaced by offset wall consoles.
- For a concrete mounting substructure; adapter plates are required for other substructures.
- In the case of the Free installation version with offset wall console, the beam cover is omitted, creating a gap between the beam and the installation point. Angle bracket or cover on request.

Drive variants

- Motor

Motor

- WMS-LP (WMS)

⊕ see "Drive variants", Page 201

Colours

- WAREMA Colour World, Individual category, fine texture surface quality
- WAREMA Colour World, Highlight category, fine texture surface quality
- WAREMA Colour World, Variation category, fine texture surface quality

Colours, optional:

- WAREMA Colour World

⊕ see "Colours and finishes", Page 10

Notes

Notes on installation

Limit position learning:

The WAREMA Smart programming cable is required to set the motor limit positions.

Notes on operation

To ensure convenient and fast operation of the slat roof, we recommend WMS WebControl pro (control via smartphone, tablet, etc.) and WMS Weather station plus in order to use the control modes (e.g. sun control). To do so, a sufficiently strong radio reception must be ensured.

Supplementary accessories

- Design radiant heater
- Lamaxa lighting
- Integrated awnings with easyZIP guidance
- Additional pole - L60/L70
- Offset pole - L60/L70
- Glass sliding system SL20e
- Sliding shutters - L50/L60/L70
- Power socket
- Protection profile

⊕ see "Supplementary accessories", Page 143

Construction limit values

Configuration variants	Minimum order width	Maximum order width	Minimum order length	Maximum order length	Maximum order area	Minimum headroom	Maximum headroom
Slat							
Slat - L60	2500 mm	4750 mm	2000 mm	6330 mm	30 m ²	1200 mm	2700 mm

Pole height:

- Minimum height for poles with drainage: 1200 mm
- Minimum height for poles without drainage: 550 mm
- Maximum pole height (headroom plus floor recess) is ≤ 3000 mm.

Dimension determination

The headroom of each pole can be ordered individually (e.g. in case of a sloping finished floor).

L60, field definition

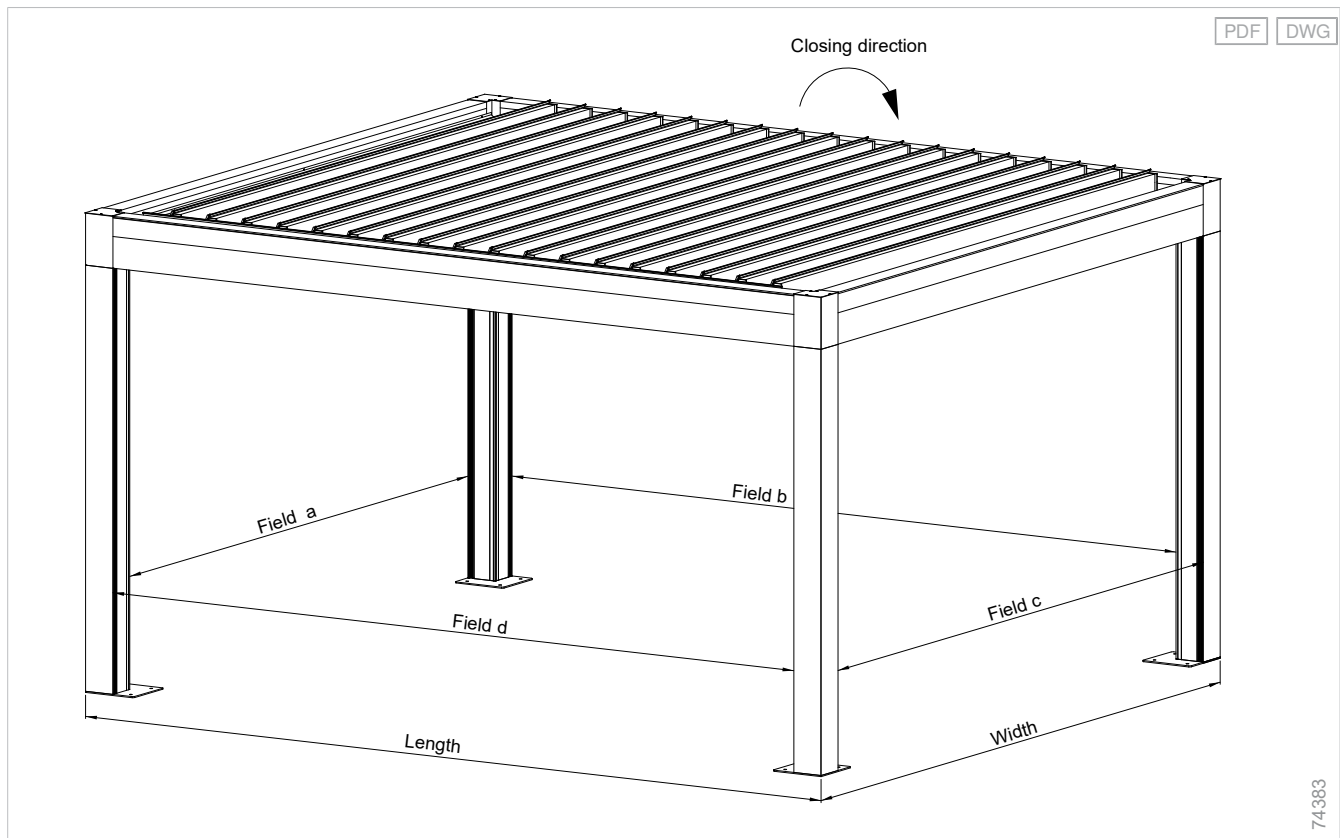

Top view of the position/connection points - L50/L60/L70

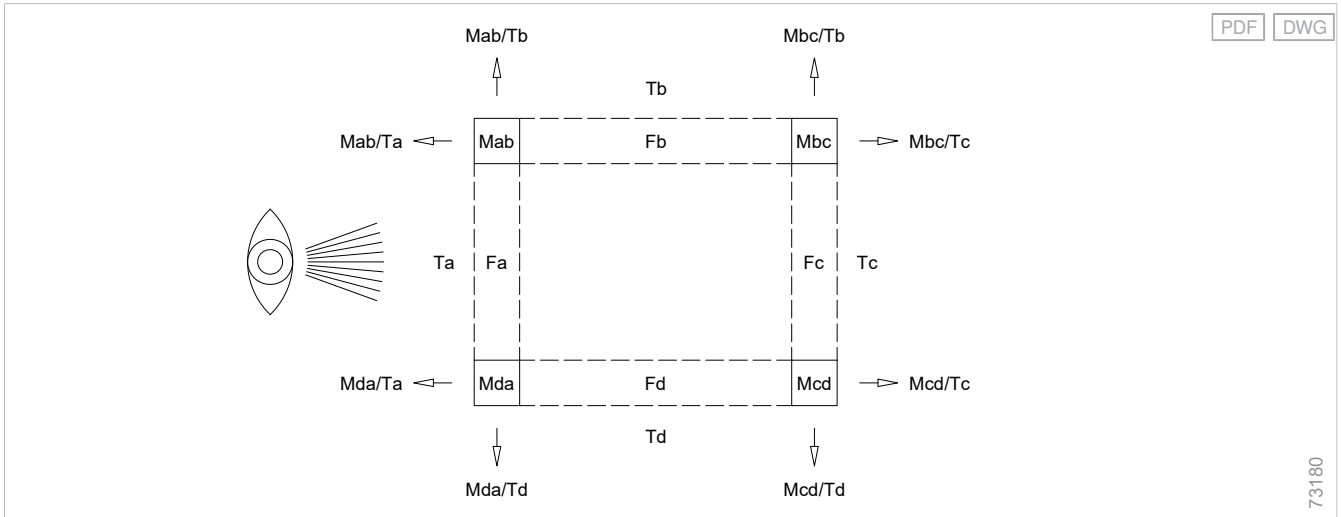

F Field
 M Point of installation (pole or wall connection)
 T Crossbeam

L60, open slats, side view

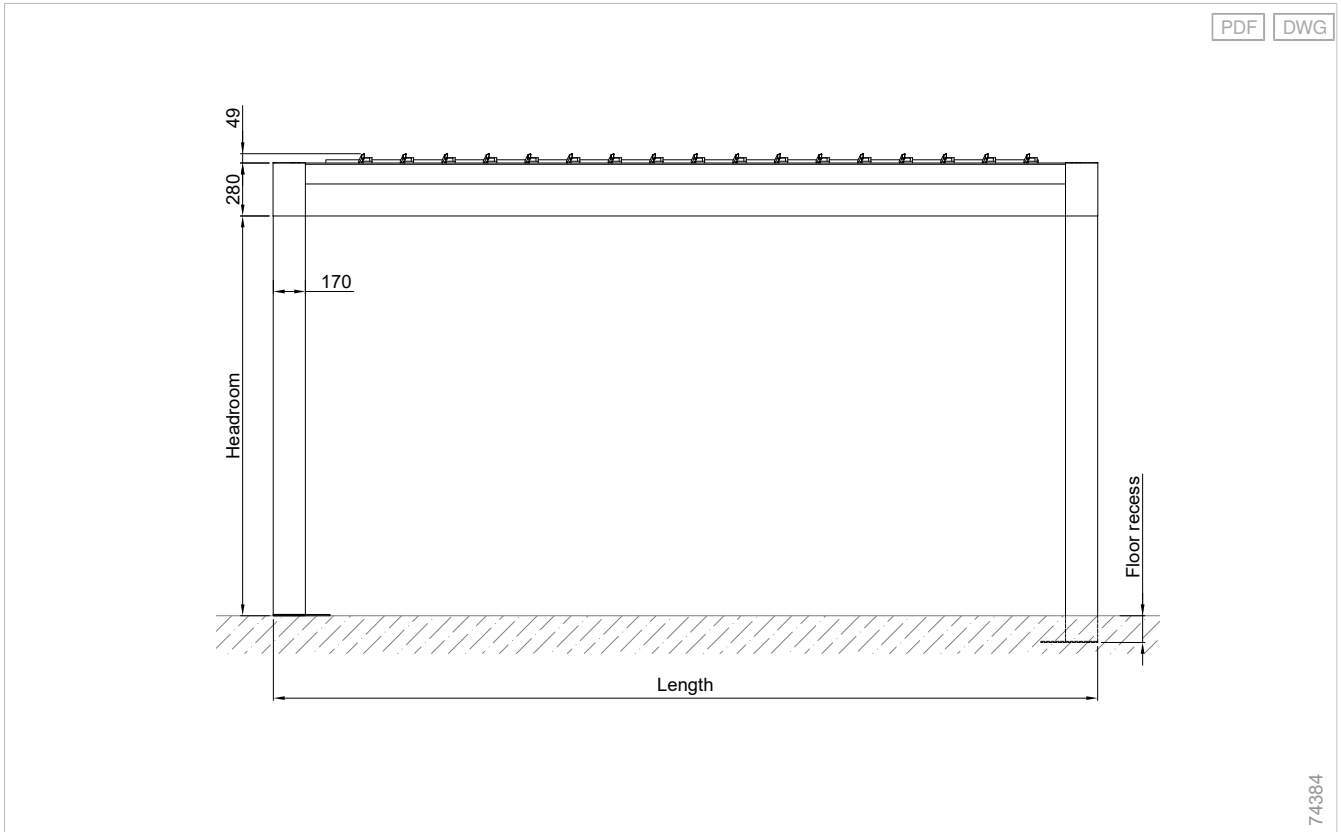

When closed, the slats do not protrude beyond the crossbeam.

L60/L70, wall console

PDF DWG

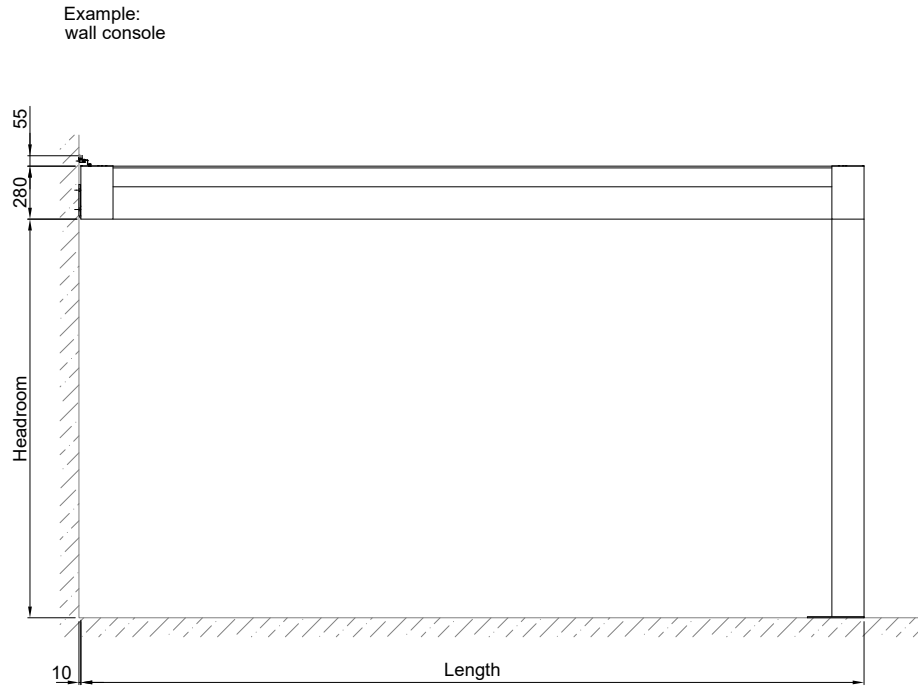
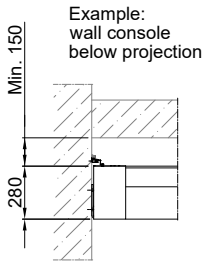

74361

Planning

Slat roofs
Lamaxa

Glass roofs
Lamaxa

L60/L70, wall console, guide rail pole

PDF DWG

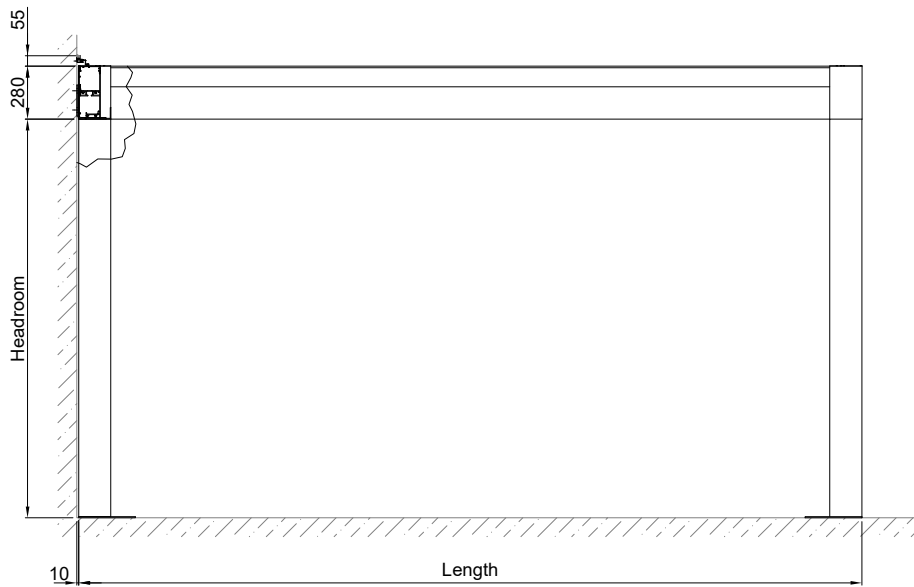

74362

Fabric roofs
Lamaxa

Supplementary
accessories

Drive
variants

Standards

L60/L70, dimension determination, order dimension

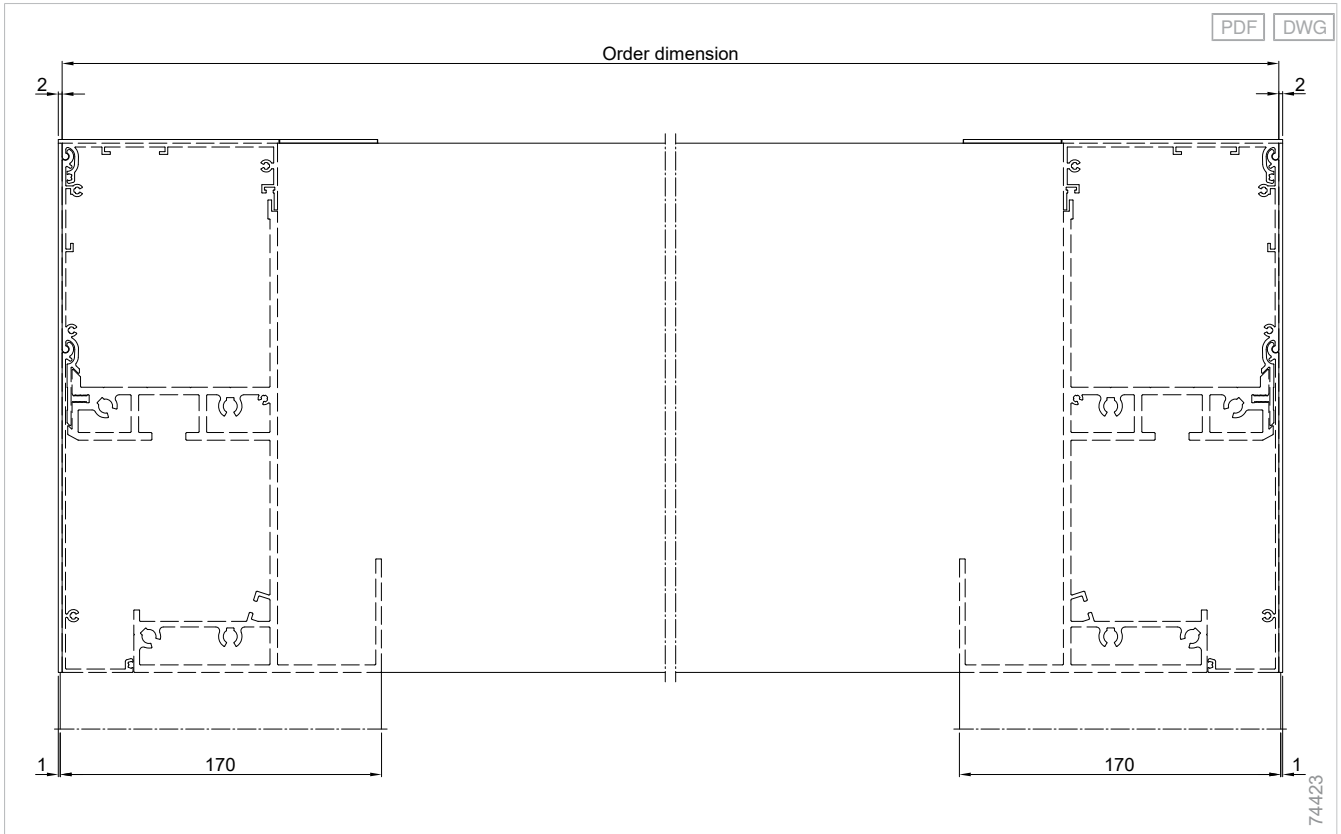

L60/L70, Free-installation with offset wall console

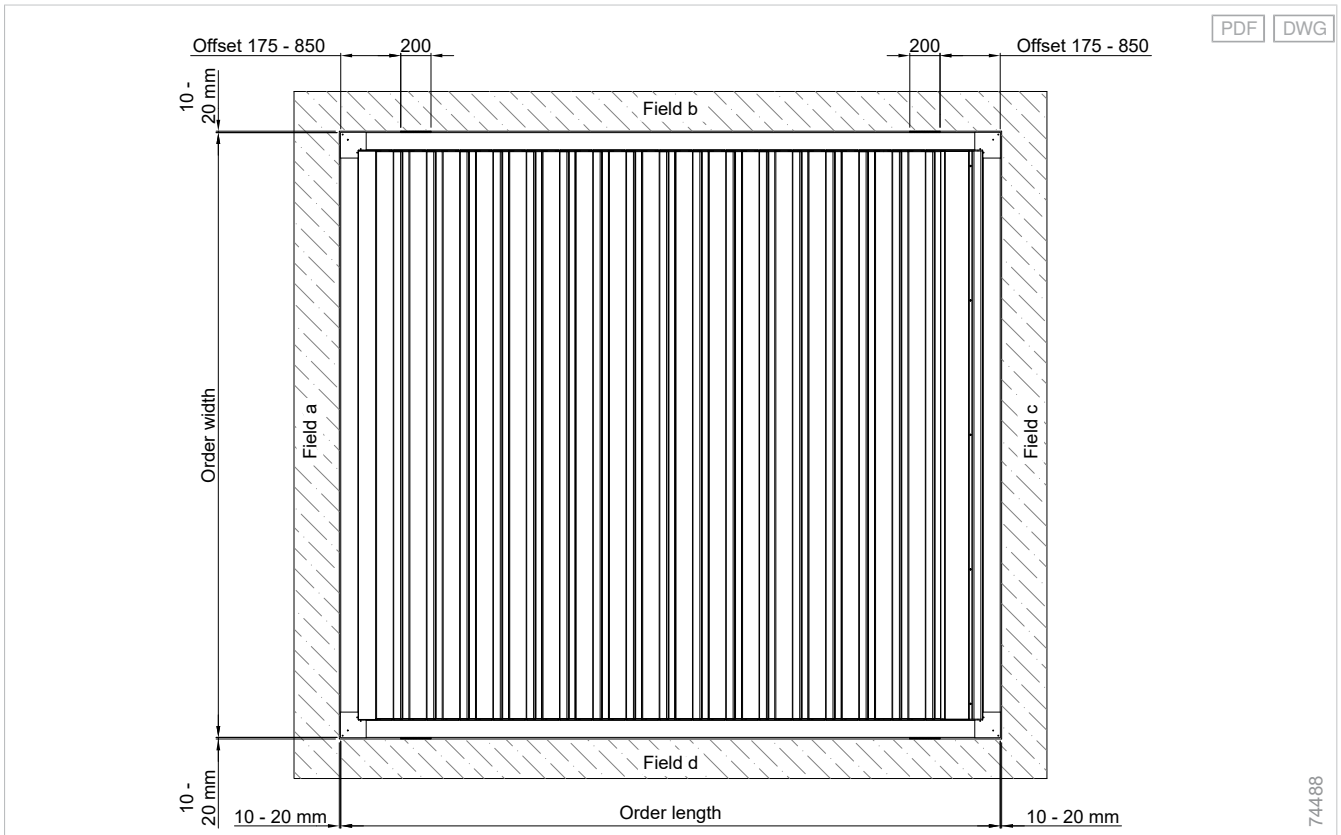

L60/L70, Free-installation with offset wall console

PDF DWG

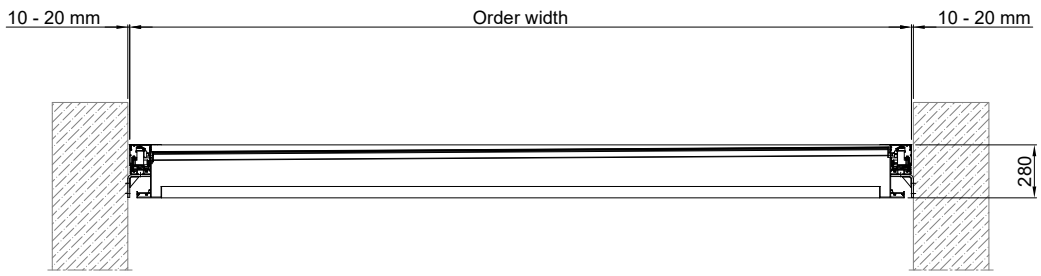

74489

Planning

Slat roofs
Lamaxa

Glass roofs
Lamaxa

Fabric roofs
Lamaxa

Supplementary
accessories

Drive
variants

Standards

Weight assessment

Weight assessment for roof systems

Order length	Order width					
	2500 mm	2501 - 3000 mm	3001 - 3500 mm	3501 - 4000 mm	4001 - 4500 mm	4501 - 4750 mm
2000 - 2500 mm	460 kg	491 kg	523 kg	554 kg	586 kg	602 kg
2501 - 3000 mm	489 kg	523 kg	558 kg	592 kg	627 kg	644 kg
3001 - 3500 mm	517 kg	555 kg	593 kg	631 kg	668 kg	687 kg
3501 - 4000 mm	560 kg	603 kg	645 kg	688 kg	731 kg	752 kg
4001 - 4500 mm	589 kg	635 kg	681 kg	726 kg	772 kg	795 kg
4501 - 5000 mm	618 kg	667 kg	716 kg	764 kg	813 kg	838 kg
5001 - 5500 mm	661 kg	715 kg	768 kg	822 kg	875 kg	902 kg
5501 - 6000 mm	678 kg	733 kg	788 kg	843 kg	898 kg	926 kg
6001 - 6330 mm	695 kg	752 kg	809 kg	865 kg	922 kg	950 kg

Quantity determination

Number of slats

Order length	Number of slats
2000 mm	7
2178 mm	8
2398 mm	9
2618 mm	10
2838 mm	11
3058 mm	12
3278 mm	13
3498 mm	14
3718 mm	15
3938 mm	16
4158 mm	17
4378 mm	18
4598 mm	19
4818 mm	20
5038 mm	21
5258 mm	22
5478 mm	23
5698 mm	24
5918 mm	25
6138 mm	26

Order length:

- The order length in the table is the dimension with the smallest possible length equalization plates and hence corresponds to the optimum order dimension (except order length 2000 mm).

Details

L50/L60 slats

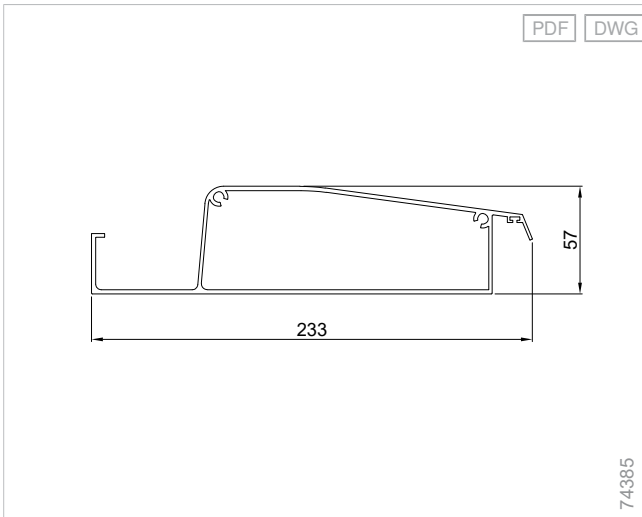

L60/L70, pole

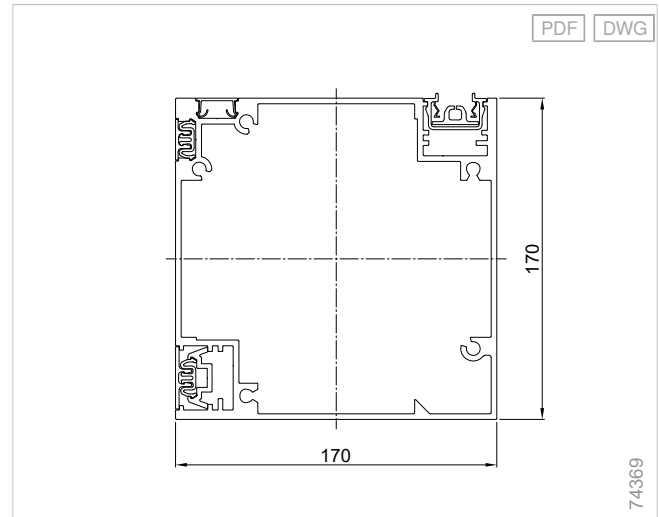

L60/L70, crossbeam a/c

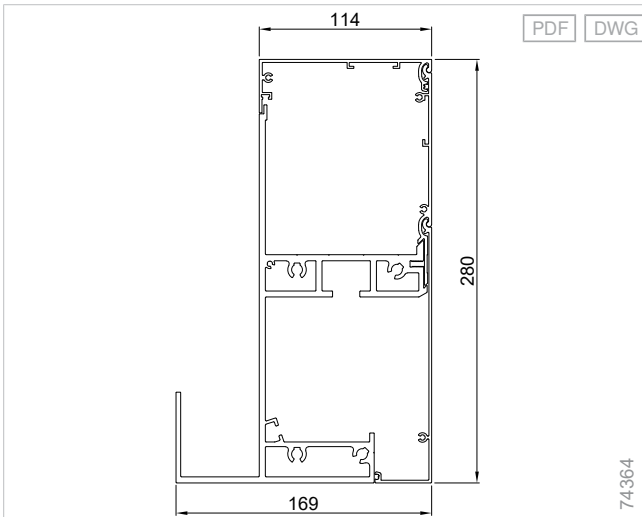

L60/L70, internal base plate

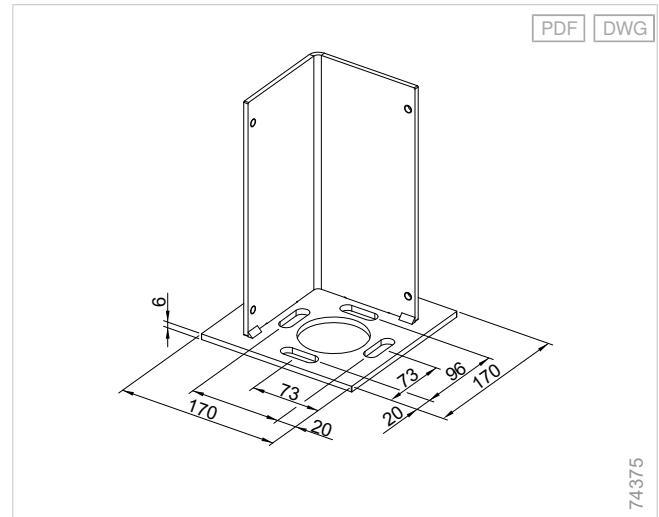

Tilting mechanism via push rod - L50/L60

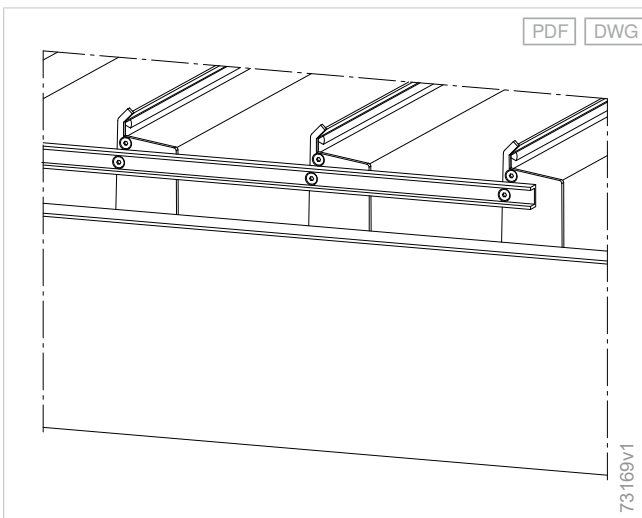

L60/L70, base plate corner installation

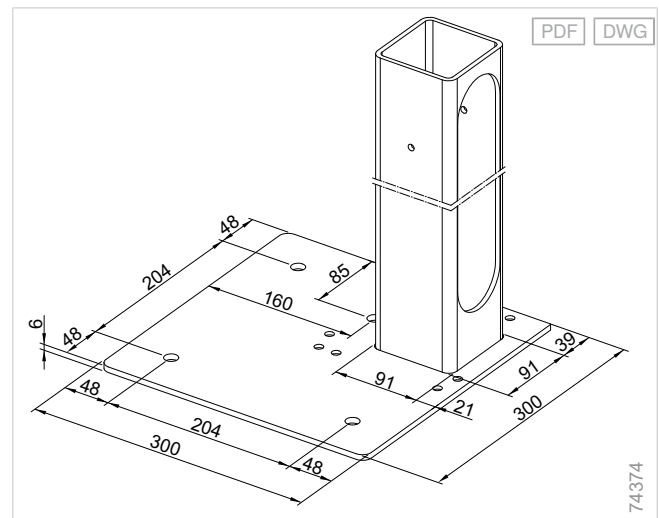

In case of the L50 the push rod is always positioned opposite the drainage. The position of the push rod can be selected for L60.

Planning

Slat roofs
Lamaxa

Glass roofs
Lamaxa

Fabric roofs
Lamaxa

Supplementary
accessories

Drive
variants

Standards

L60/L70, position of drainage, rectangular

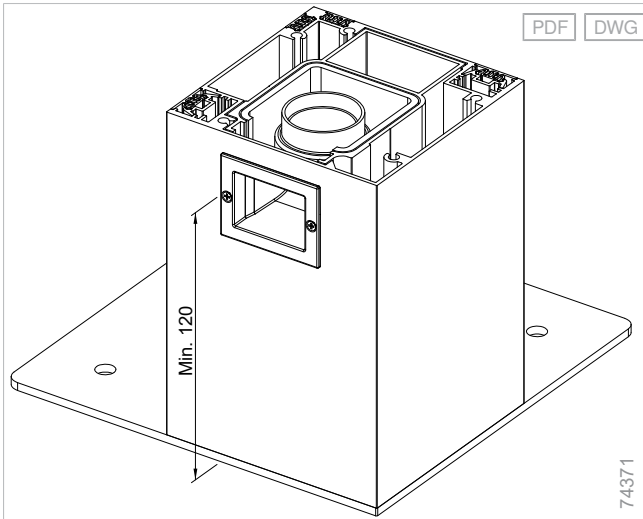

L60/L70, position of drainage, rectangular, optional waterspout

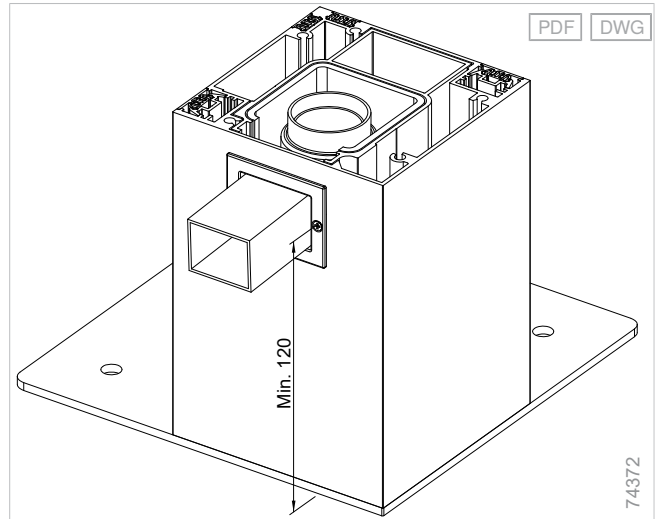

L60/L70, position of drainage, on-site

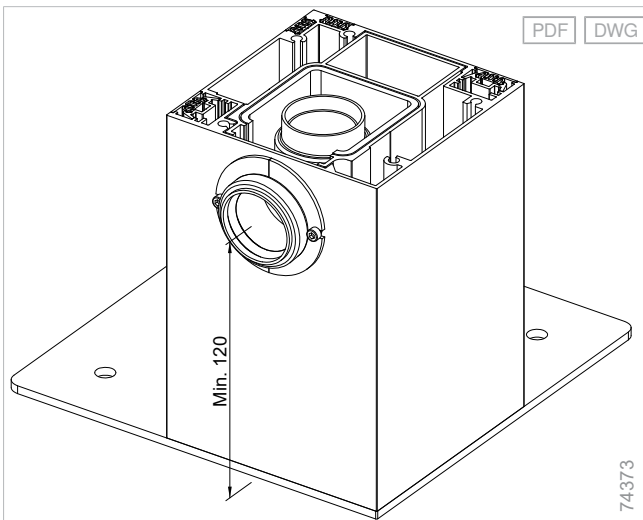

L60, length compensation plates, electrical distribution on crossbeam a

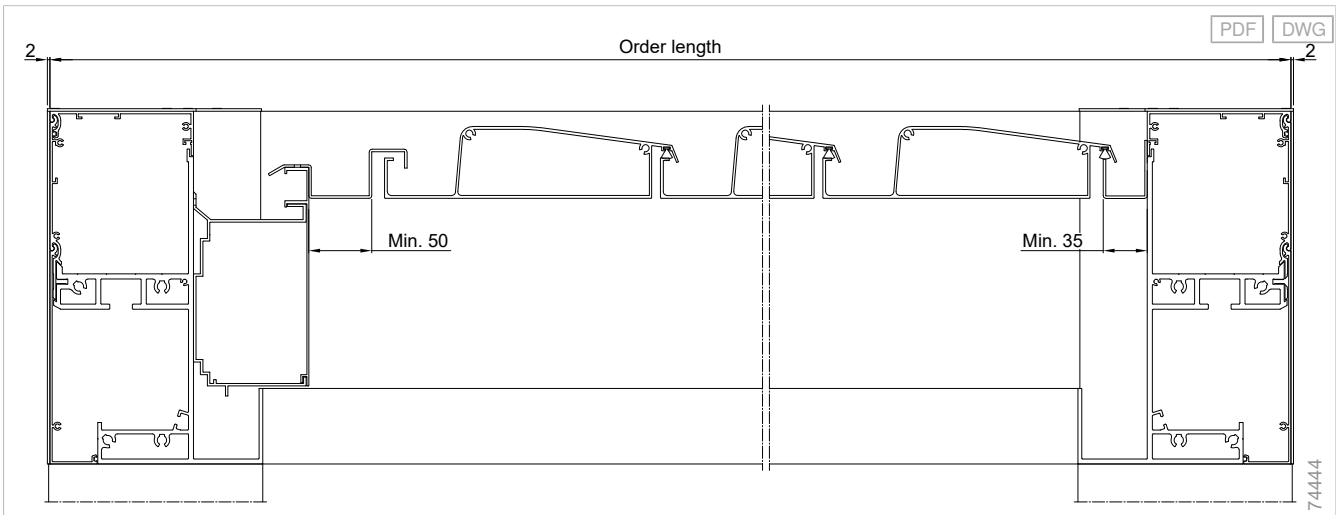

L60, length compensation plates, electrical distribution on crossbeam c

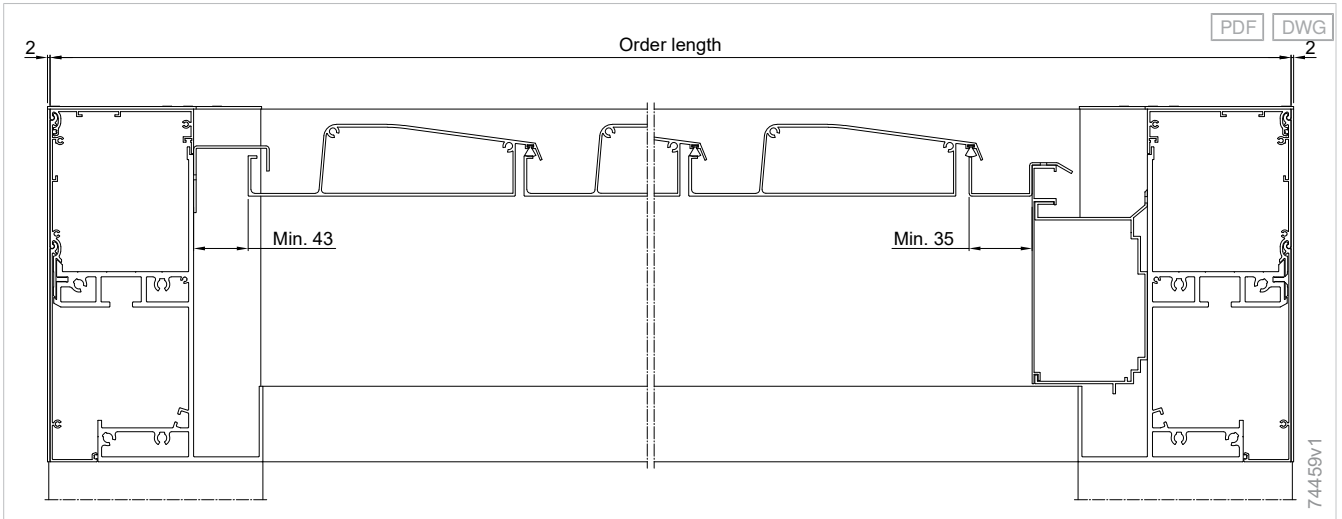

L60, slat inclination

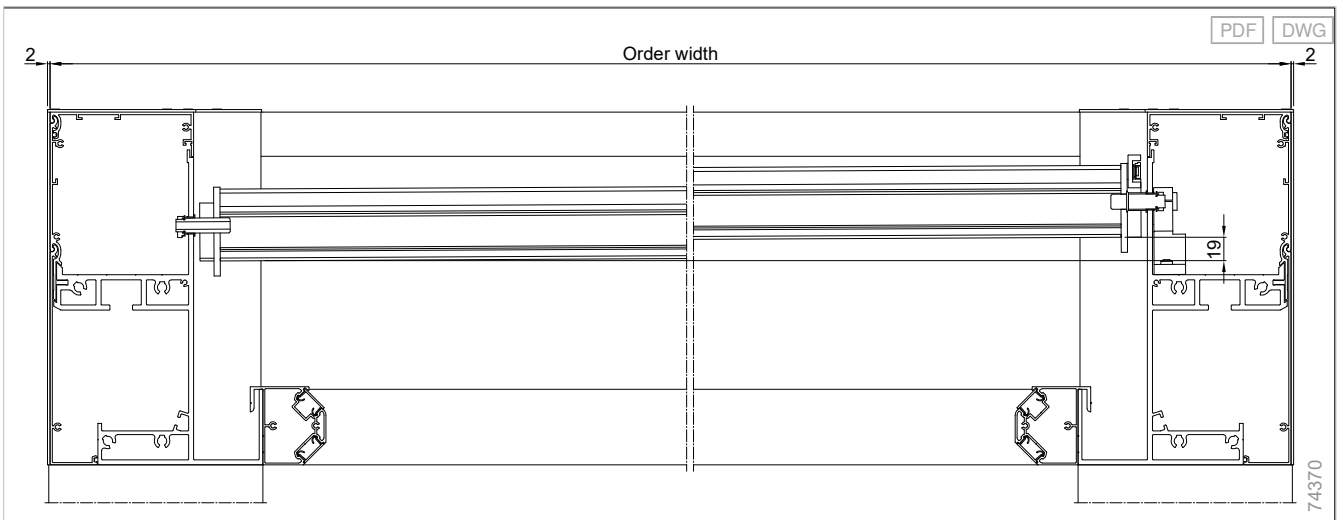

Planning

Slat roofs
Lamaxa

Glass roofs
Lamaxa

Fabric roofs
Lamaxa

Supplementary
accessories

Drive
variants

Standards

L60/L70, wall console

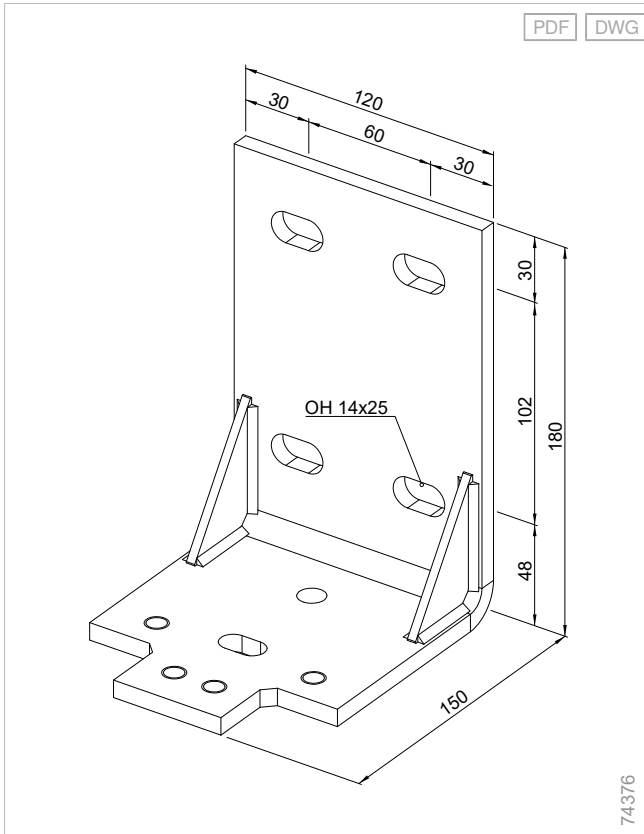

L60/L70, wall console, lateral trim panel

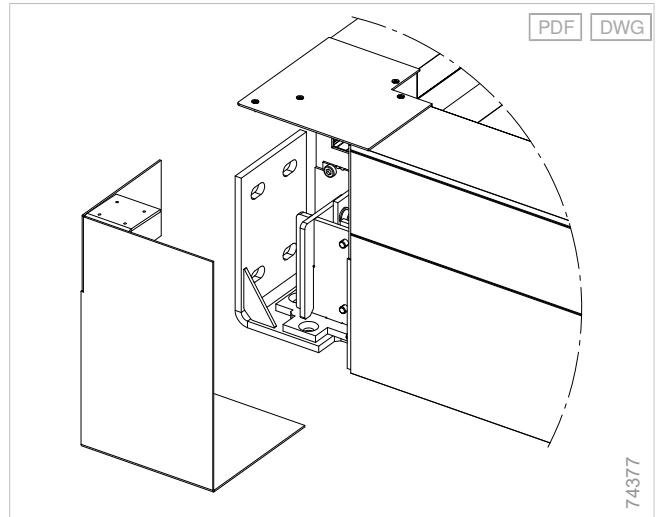

L60/L70, offset wall console

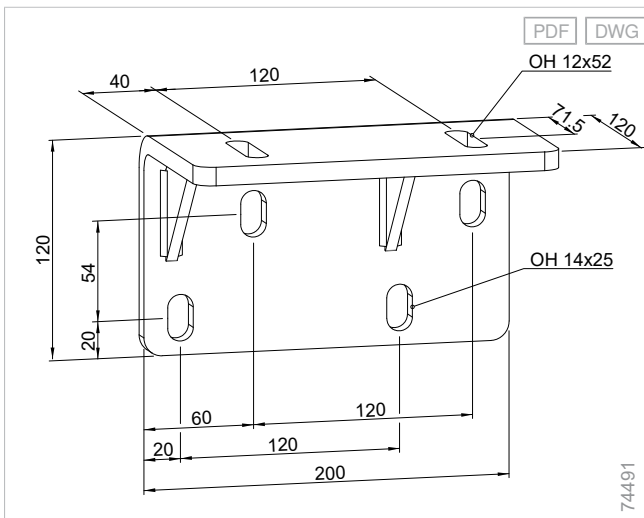

L60/L70, wall console, lateral facing, inner angle

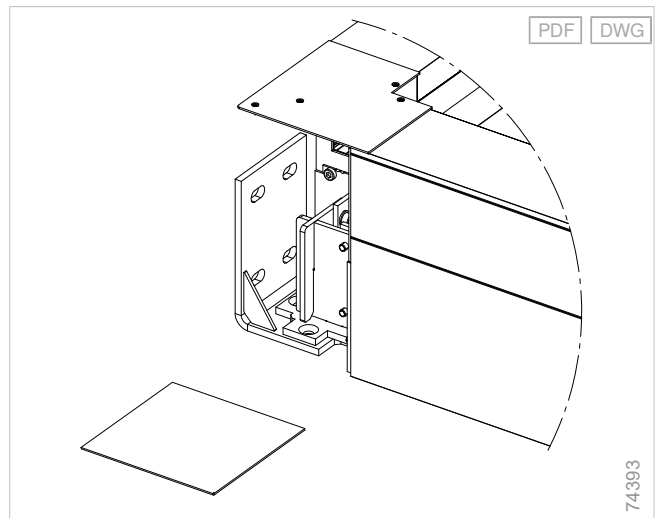

Wall connection profile with small rain hood - L50/L60/L70

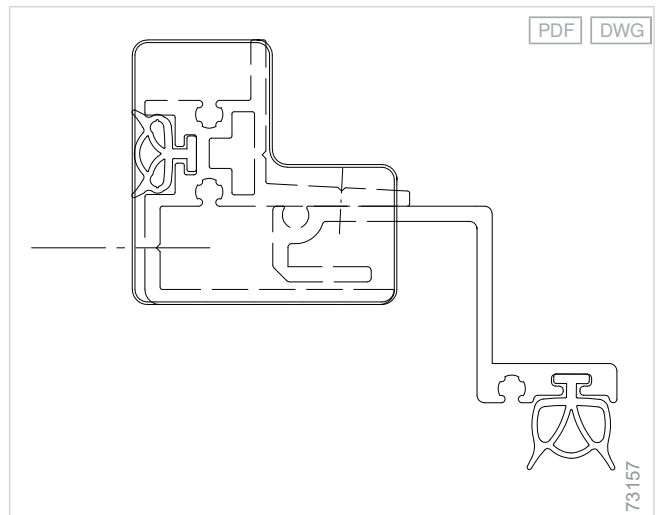

Additional product information

Pole installation options

Ground installation with frost-proof on-site foundation, see slat roof guidelines (IVRSA).

Mounting examples

L60/L70, floor recess, separation cut

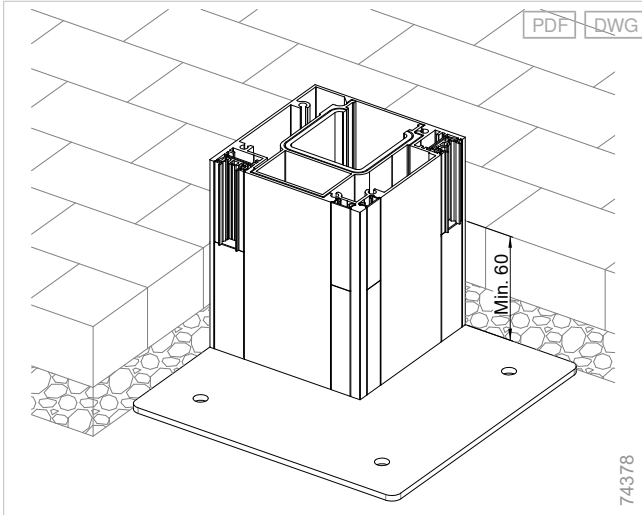

L60/L70, base plate corner installation

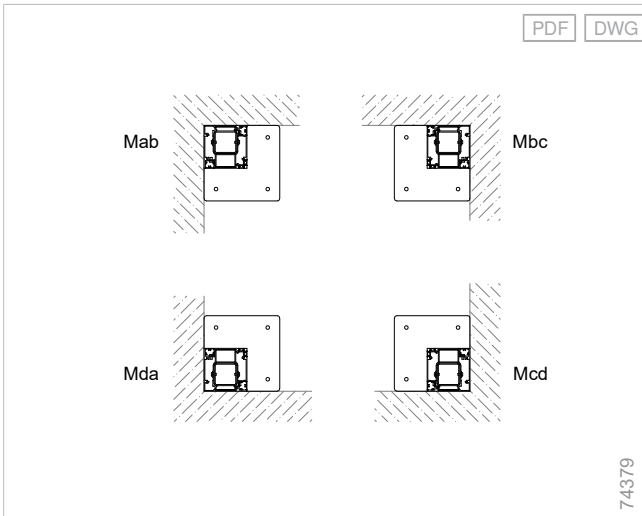

L60/L70, shim plate

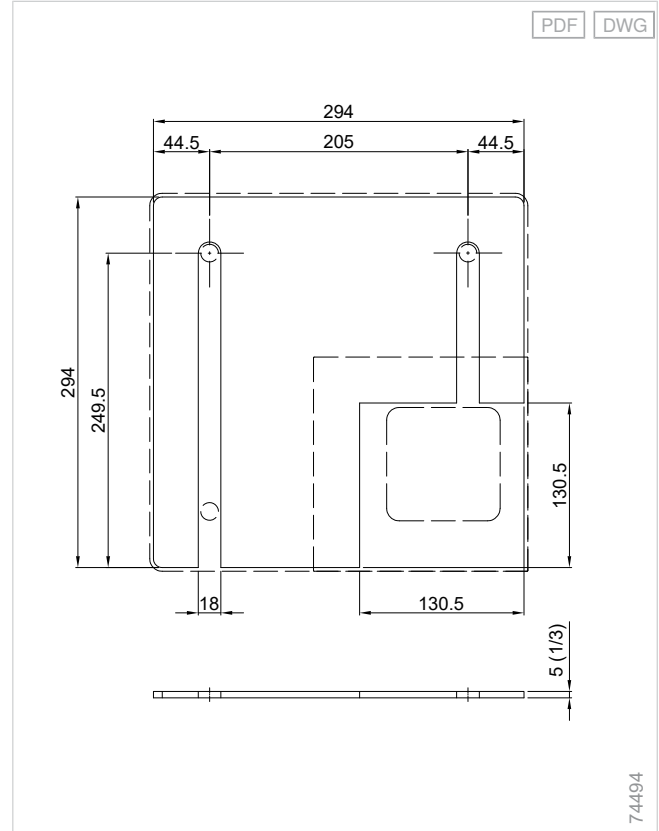

L60/L70, quarter shim plate

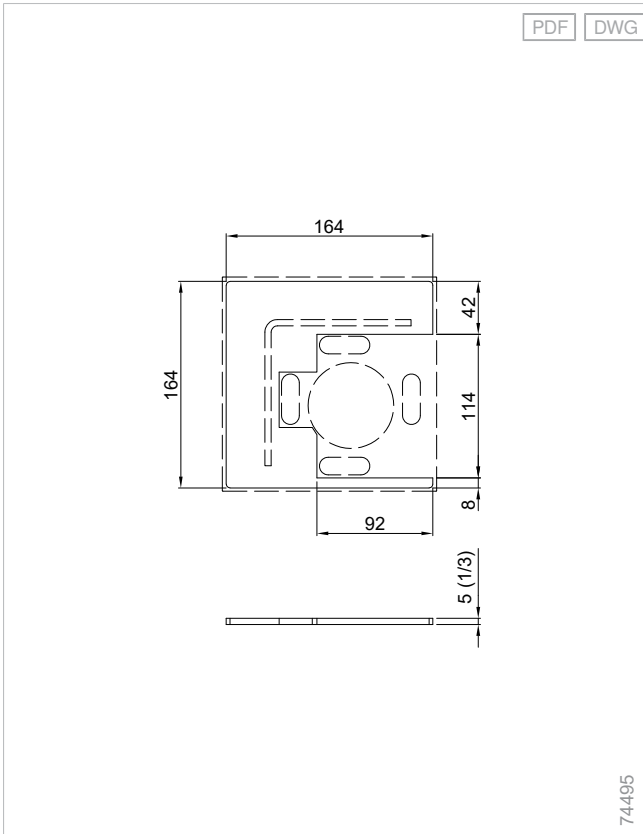

L60/L70, wall connection

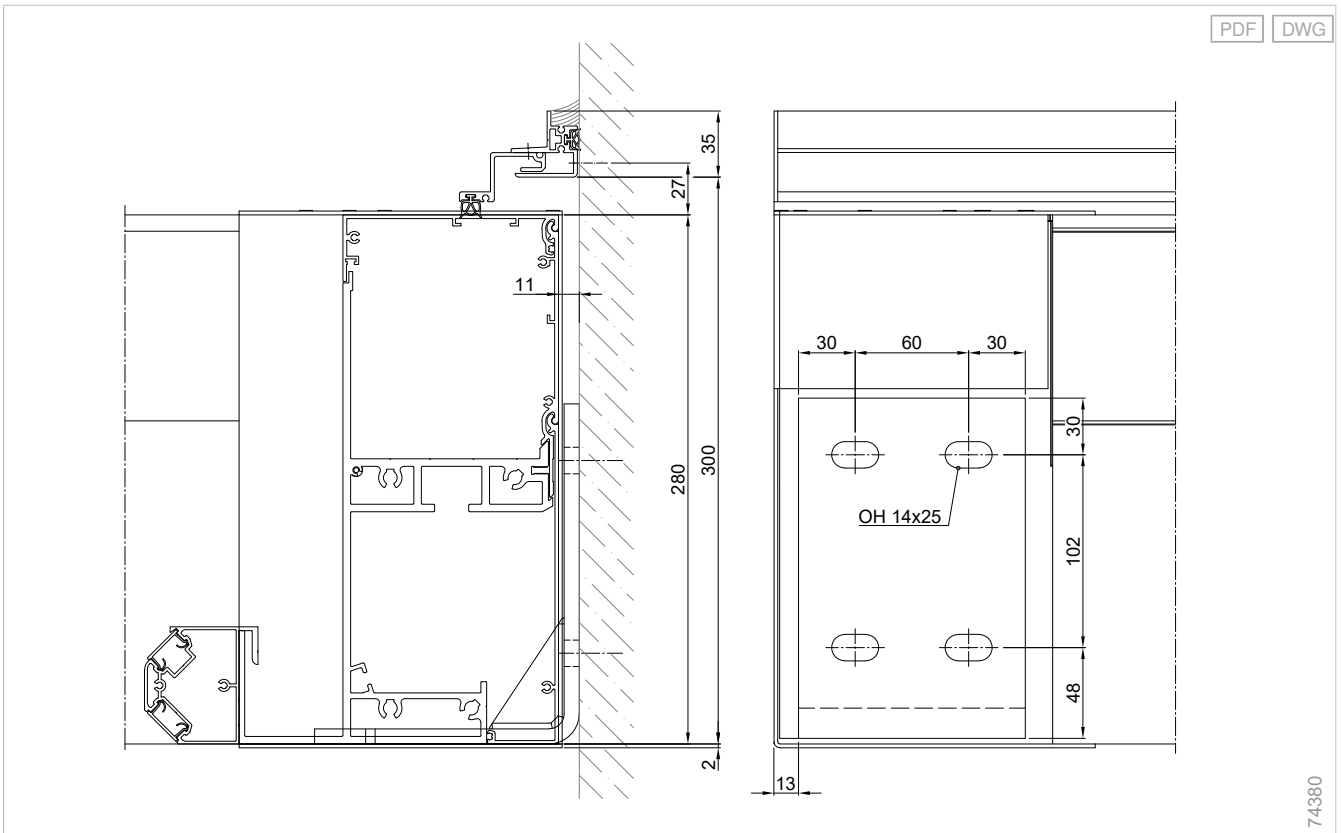

L60/L70, Free-installation with offset wall console

PDF DWG

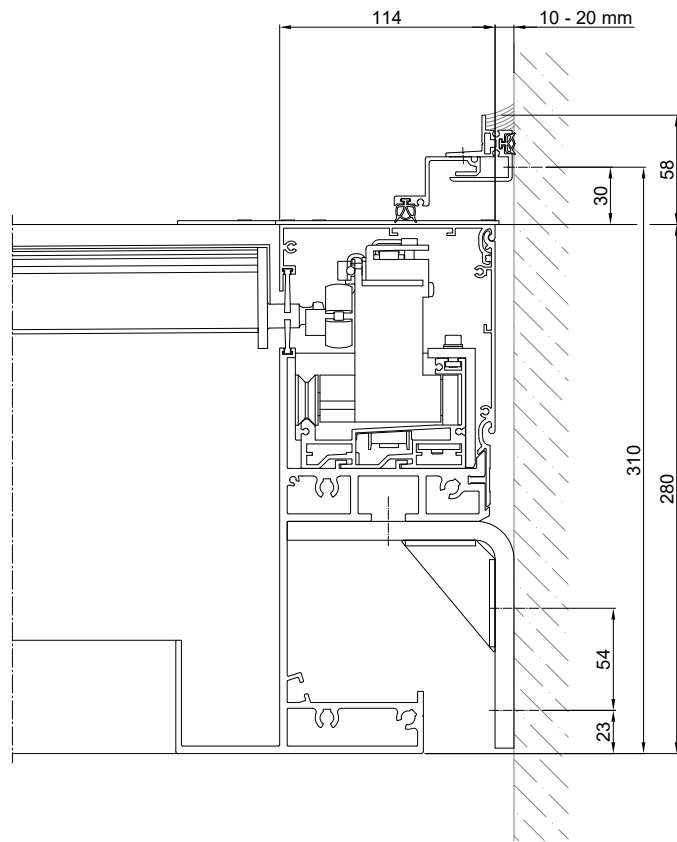

74490

In the case of the Free installation version with offset wall console, the beam cover is omitted, creating a gap between the beam and the installation point. Angle bracket or cover on request.

Planning

Slat roofs
Lamaxa

Glass roofs
Lamaxa

Fabric roofs
Lamaxa

Supplementary
accessories

Drive
variants

Standards

L60/L70, awning with easyZIP guidance, refurbishment

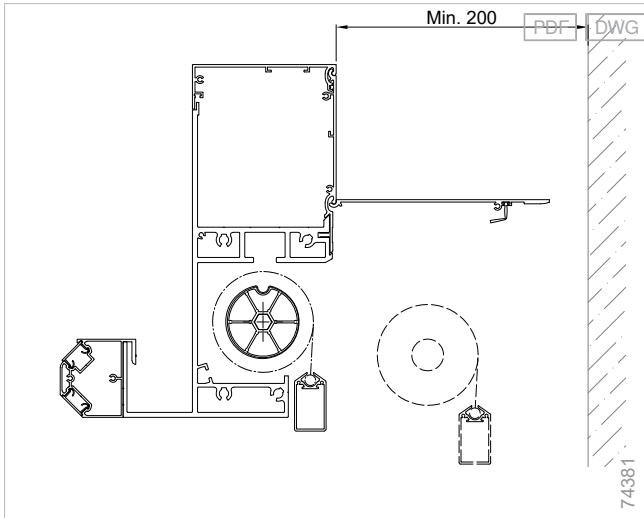

L60/L70, Design radiant heater

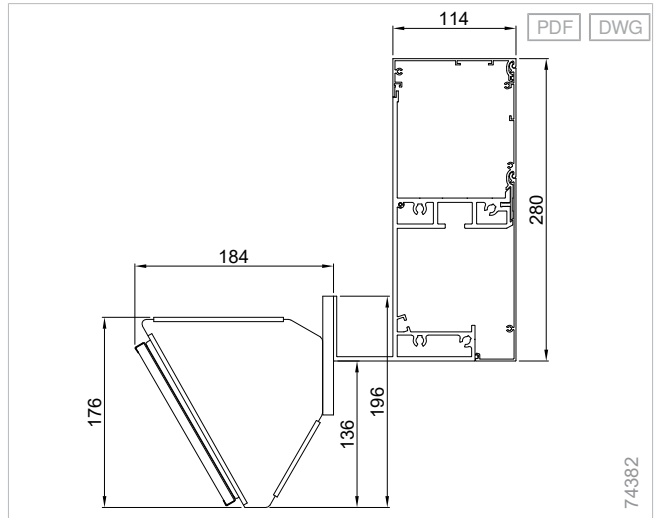



Roof systems

Slat roofs Lamaxa L60 Line

Elegantly connected

Shading of very large areas: With a central pole, several units can be elegantly lined up along the long as well as the short side.

Combinable

Double the flexibility: Combinations of the L60 (tiltable slats) and L70 (tiltable and movable slats) make individual solutions a possibility.

Year-round use

Protection in all weather: Depending on the type, the incidence of light can be adjusted to various levels with the pivotable slats – all the way to a complete closure of the slat roof.

Construction limit values

Maximum order width	9000 mm
Maximum order length	12000 mm
Maximum order area	54 m ²

Order here

myWAREMA

[Art.-Nr. 2072961](#)

WAREMA tools

[Sun Shading Planner](#)

[+ see "Navigating the document", Page 5](#)

Components

Lamaxa Line - L60/L70

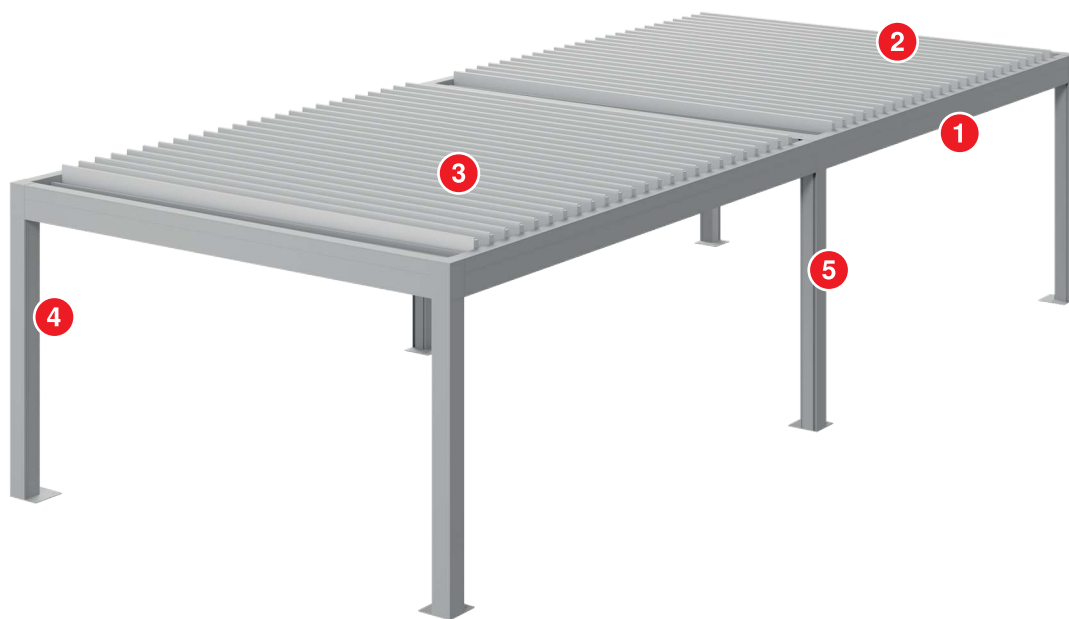

- 1 Crossbeam with tilting mechanics
- 2 Crossbeam with motor
- 3 Slats

- 4 Pole
- 5 Middle pole

Lamaxa Line - L60/L70

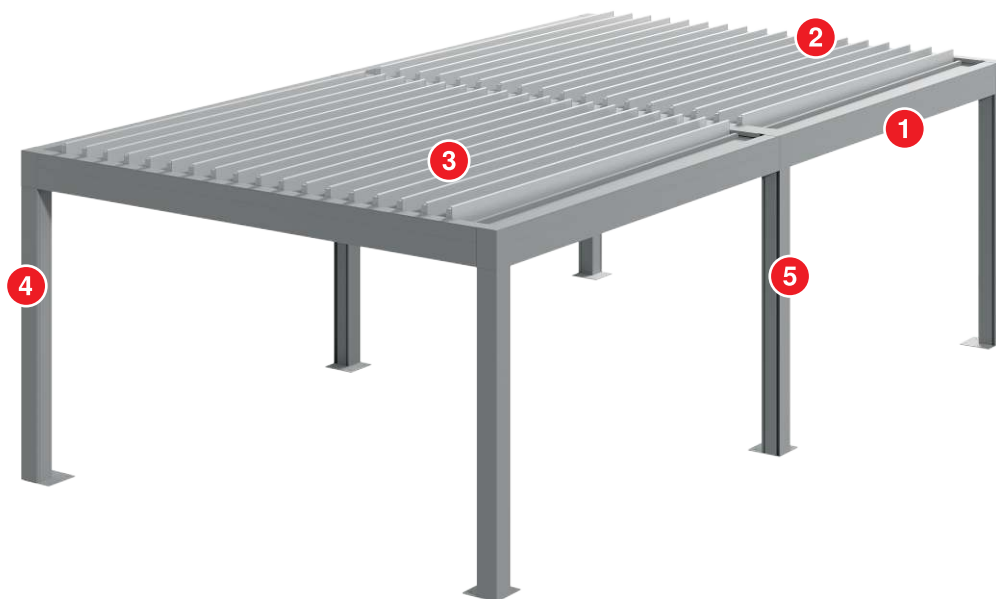

- 1 Crossbeam with motor
- 2 Crossbeam with tilting mechanics
- 3 Slats

- 4 Pole
- 5 Middle pole

Planning

Slat roofs
Lamaxa

Glass roofs
Lamaxa

Fabric roofs
Lamaxa

Supplementary
accessories

Drive
variants

Standards

Slat

Slat - L60

Material	Aluminium, extruded
Surface	Powder-coated
Width	233 mm
Height	57 mm
Swivelling range	0 - 135 °

Pole

Pole - L60/L70

Material	Aluminium, extruded
Surface	Powder-coated
Width	170 mm
Height	170 mm

Installation options:

- Ground installation with frost-proof, on-site foundation.
- The grout for filling the clearance is not included in the scope of delivery when threaded rods are used.

Floor recess and separation cut:

- For a floor recess, we recommend the use of a separation cut in the inspection parts to allow for inspection without dismantling the floor.
- If the floor recess does not have a separation cut, the easyZIP guidance inlays and the integrated LED strips reach the bottom edge of the pole profile.
- Floor recesses with a separation cut must be at least 60 mm.

Centre pole - L60/L70 Line

Material	Aluminium, extruded
Surface	Powder-coated
Width	170 mm
Height	170 mm

Installation options:

- Ground installation with frost-proof, on-site foundation.
- The grout for filling the clearance is not included in the scope of delivery when threaded rods are used.

Floor recess and separation cut:

For a floor recess, we recommend the use of a separation cut in the inspection parts to allow for inspection without dismantling the floor. If the floor recess does not have a separation cut, the easyZIP guidance inlays and the integrated LED strips reach the bottom edge of the pole profile.

Pole, optional

Pole guide rails - L60/L70

Material	Aluminium, extruded
Surface	Powder-coated
Width	170 mm
Height	170 mm

If an easyZIP awning is installed in a field in which a wall console is installed, a separate pole is required below the wall console. Inward or outward drainage through guide rail poles possible. Only corner base plate possible.

Base plate

Base plate - corner installation L60/L70

Material	Galvanised steel
Surface	Plain
Optional surface	Powder-coated
Width	300 mm
Height	300 mm

Base plate - internal L60/L70

Material	Galvanised steel
Surface	Plain
Optional surface	Powder-coated
Width	170 mm
Height	170 mm

Since the material thickness is generally visible, the internal base plate should be coated if there is no floor recess.

Crossbeam

Crossbeam - L60/L70

Material	Aluminium, extruded
Surface	Powder-coated
Width	169 mm
Height	280 mm

Middle crossbeam - L60 Line

Material	Aluminium, extruded
Surface	Powder-coated
Width	170 mm
Height	280 mm

Electrical distribution on the crossbeam

Material	Aluminium, extruded
Surface	Powder-coated
Width	91,5 mm
Height	174 mm

Drainage

Drainage in pole - L60/L70 Line

- Drainage through drainpipe in pole
- If each roof crown is smaller than 16 m², one drainage point per roof is sufficient to comply with an average rainfall event $r_{5/2} = 350 \text{ l/(s ha)}$. If a roof crown is $\geq 16 \text{ m}^2$, it must be equipped with a second drainage point.
- To withstand average rainfall, three drainage points are sufficient for a total area of up to 54 m² if each roof is equipped with a separate drainage point plus a third common drainage point at the centre pole.

Position of drainage outlet:

- Possible on every pole
- Drainage and electronics/connecting lines must always be installed in separate poles.
- On the outsides of the poles or downward
- Min. height: 150 mm/height: 40 mm (for internal base plates)
- Max. height: 250 mm below the headroom

Note: Downward drainage through base plate:

When planning and measuring, please note that the concrete foundation must be very precisely manufactured if downward drainage through the base plate is required!

Wall connection profile, optional

Wall connection profile with small rain hood

Material	Aluminium, extruded
Surface	Powder-coated
Width	54 - 65 mm
Height	48 mm
Dimensions, notes	The adjustment range in the depth between rain hood and wall connection profile is up to 11 mm.

The on-site sealing is the responsibility of the specialist partner; if necessary, the commissioning of a plumbing company is recommended.

Field of application:

- Terrea K50
- Terrea K70
- Perea P20 (up to an angle of 10°)
- Lamaxa L50/L60/L70

Console, optional

Wall console - Lamaxa L60/L70

Material	Galvanised steel
Surface	Powder-coated
Width	120 mm
Height	180 mm
Depth	140 mm

- Use in corner as pole replacement.
- A maximum of two poles can be replaced by wall consoles.
- For a concrete mounting substructure; adapter plates are required for other substructures.
- The wall console protrudes 11 mm beyond the order width and order length. This results in a gap of 11 mm between the crossbeam and the wall.
- For inner angle wall consoles, the lateral corner area is not covered by profiles.

Offset wall console - Lamaxa L60/L70

Material	Aluminium, extruded
Width	200 mm
Height	120 mm
Depth	120 mm

- For attachment to Tb and/or Td.
- Use in corner as pole replacement or as Free installation.
- A maximum of 4 poles can be replaced by offset wall consoles.
- For a concrete mounting substructure; adapter plates are required for other substructures.
- In the case of the Free installation version with offset wall console, the beam cover is omitted, creating a gap between the beam and the installation point. Angle bracket or cover on request.

Drive variants

- Motor

Motor

- WMS-LP (WMS)

+ see "Drive variants", Page 201

Colours

- WAREMA Colour World, Highlight category, fine texture surface quality
- WAREMA Colour World, Variation category, fine texture surface quality

Colours, optional:

- WAREMA Colour World

+ see "Colours and finishes", Page 10

Notes

Notes on product configuration

Series-mounted units:

- If the distance between the facade and the centre pole is ≥ 300 mm, integrated awnings with easyZIP guidance can be installed in the fields adjacent to the centre pole. If the distance is < 300 mm (minimum distance 10 mm), no easyZIP awnings can be installed in the adjacent fields (retrofitting is also not possible).
- Generally, unit coupling (drive coupling) is not possible.
- Flush closures allow two slat roofs to be centrally mounted in-series on one common pole.
- The two slat roofs can overlap either at the order width or order length and have the same closing and extension direction (no counter-rotation).
- The order length or order width is dimensioned to the centre axis of the centre pole.
- The electrical distribution of the respective units is located on the crossbeam. The corresponding connecting line is required in a pole adjacent to the electrical distribution.
- If both electrical distributions are positioned on the overlapping crossbeams, the on-site power supply is possible via a centre pole.
- A combination of L60 and L70 is possible in both joint directions.
- It is possible to integrate easyZIP or LEDs into any side of the pole (but not below the double crossbeam in the joint area).

- RGB lighting of both units can be learned in to an RGB hand-held transmitter.
- One drainage point per 16 m^2 of roof area is sufficient per unit. Three drainage points are sufficient for a total area of up to 54 m^2 if each roof is equipped with a separate drainage point plus a third common drainage point at the centre pole.

Notes on installation

Limit position learning:

The WAREMA Smart programming cable is required to set the motor limit positions.

Notes on operation

To ensure convenient and fast operation of the slat roof, we recommend WMS WebControl pro (control via smartphone, tablet, etc.) and WMS Weather station plus in order to use the control modes (e.g. sun control).

Supplementary accessories

- Design radiant heater
- Lamaxa lighting
- Integrated awnings with easyZIP guidance
- Additional pole - L60/L70
- Glass sliding system SL20e
- Sliding shutters - L50/L60/L70
- Power socket
- Protection profile

⊕ see "Supplementary accessories", Page 143

Construction limit values

Configuration variants	Minimum order width	Maximum order width	Minimum order length	Maximum order length	Maximum order area	Minimum headroom	Maximum headroom
Slat							
Slat - L60	2500 mm	9000 mm	2000 mm	12000 mm	54 m^2	2350 mm	2700 mm

Dimension determination

The headroom of each pole can be ordered individually (e.g. in case of a sloping finished floor).

L60, Lamaxa Line

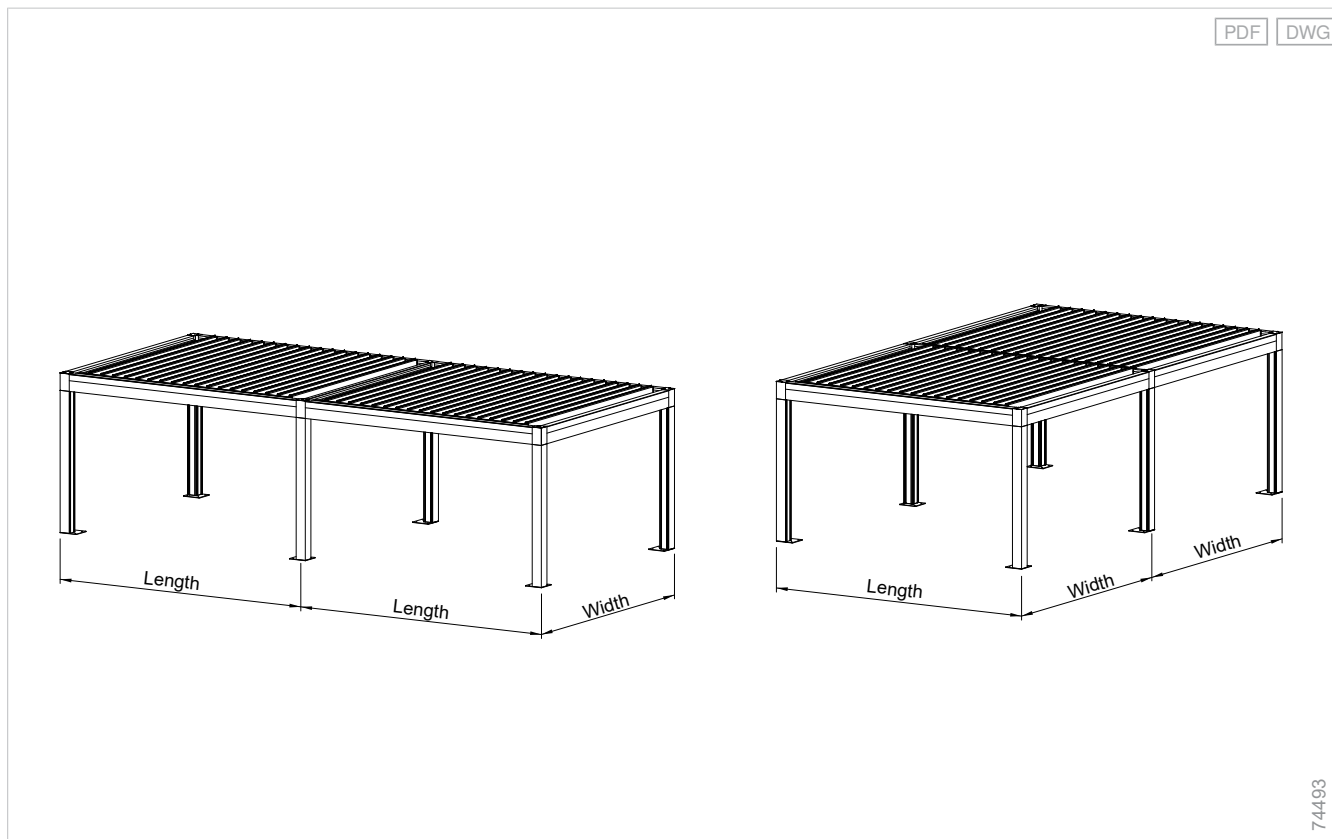

Planning

Slat roofs
Lamaxa

Glass roofs
Lamaxa

74493

Top view of the position/connection points - Lamaxa Line L50/L60/L70

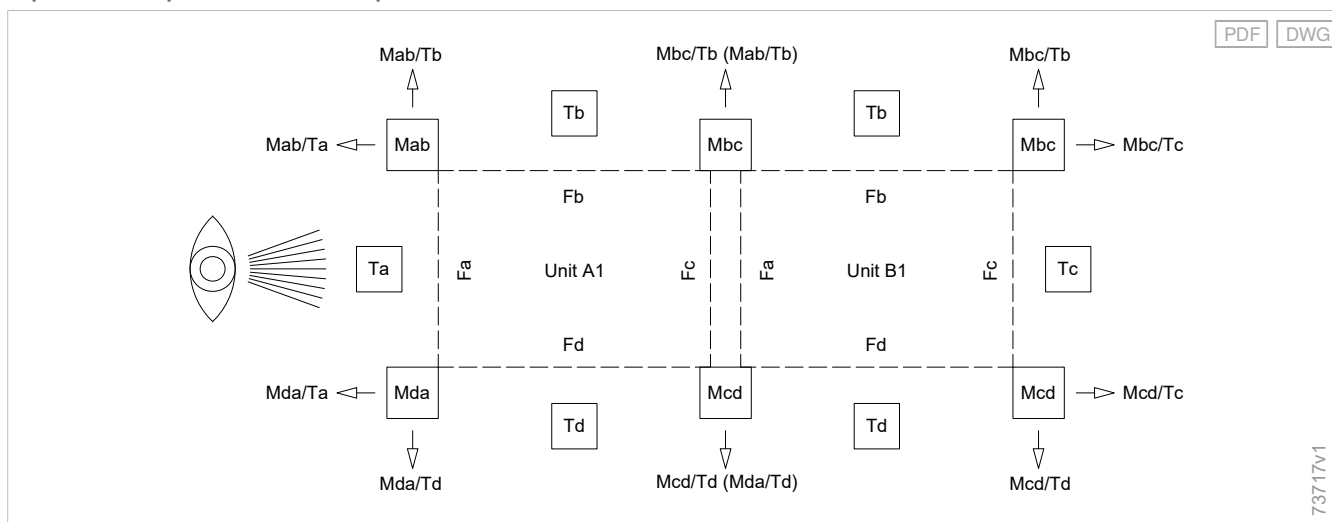

Fabric roofs
Lamaxa

Supplementary
accessories

73717v1

F Field

T Crossbeam

M Point of installation (pole or wall connection)

Drive
variants

Standards

Top view of the position/connection points - Lamaxa Line L50/L60/L70

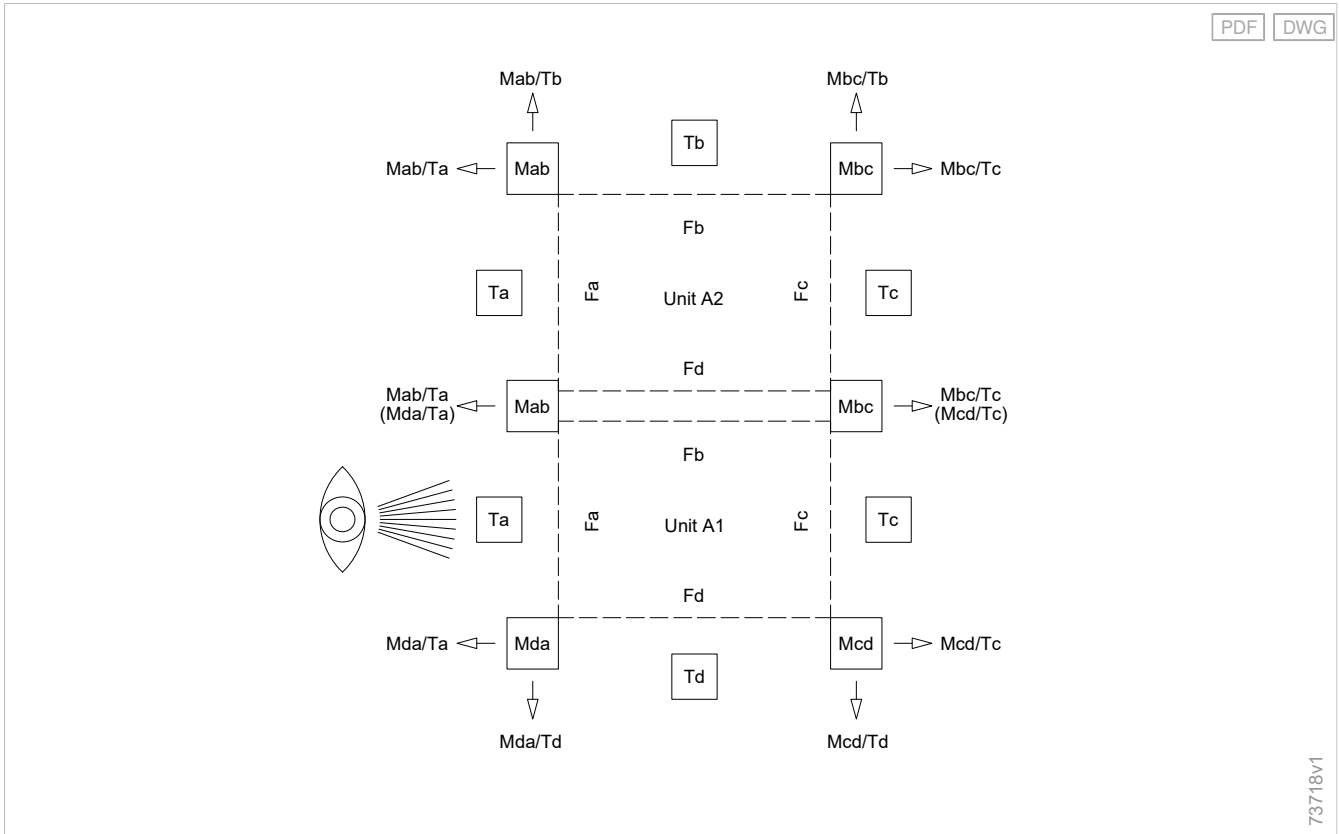

- F Field
- M Point of installation (pole or wall connection)
- T Crossbeam

L60/L70 Line, wall connection, wall console

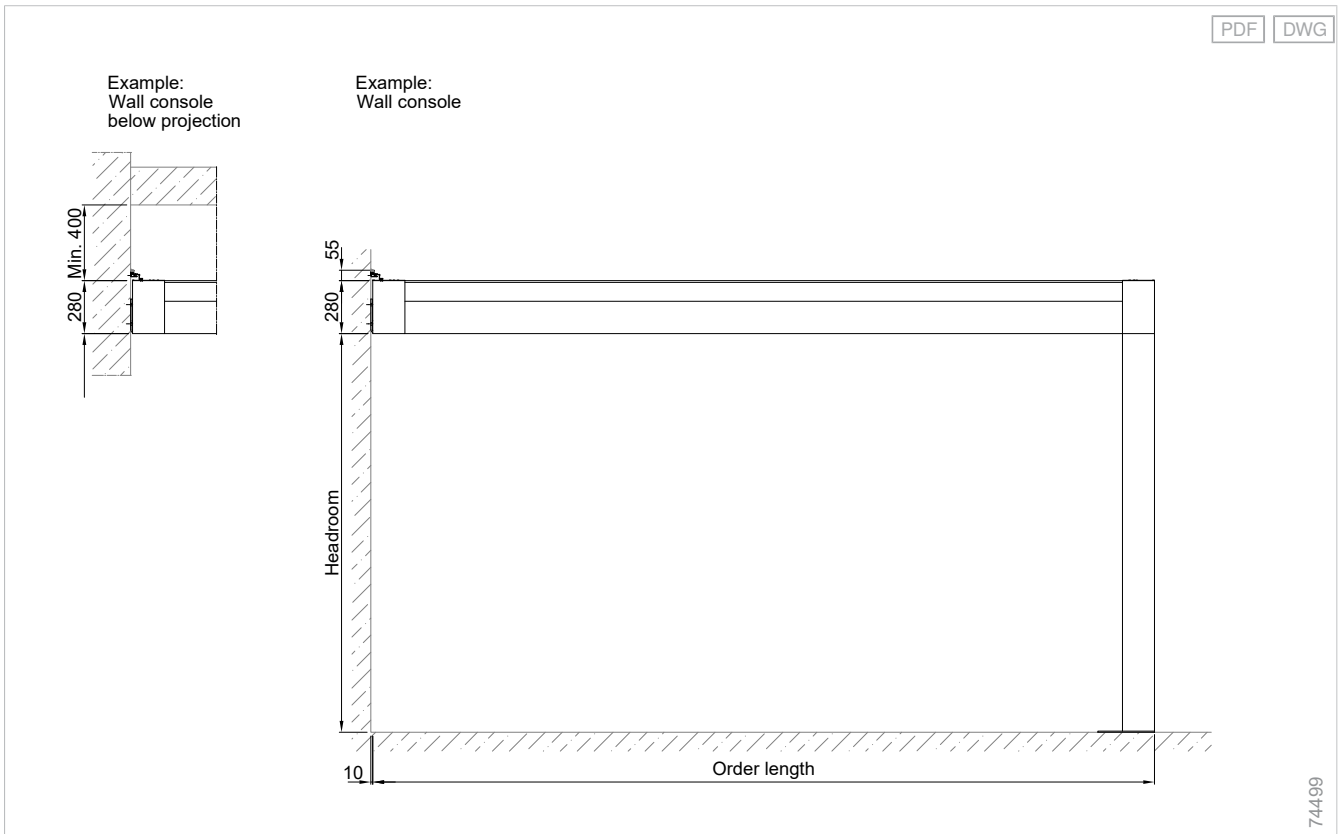

Optimum order length - L60 Line

Order length (joint order length)	Order length (joint order width)	Number of slats
2000	2000	7
2178	2094	8
2398	2314	9
2618	2534	10
2838	2754	11
3058	2974	12
3278	3194	13
3498	3414	14
3718	3634	15
3938	3854	16
4158	4074	17
4378	4294	18
4598	4514	19
4818	4734	20
5038	4954	21
5258	5174	22
5478	5394	23
5698	5614	24
5918	5834	25

Order length:

The order length in the table is the dimension with the smallest possible length equalization plates and hence corresponds to the optimum order dimension (except order length 2000 mm).

Optimum order length for Lamaxa L60/L70 Line = roof crown

Details

L60, slat inclination

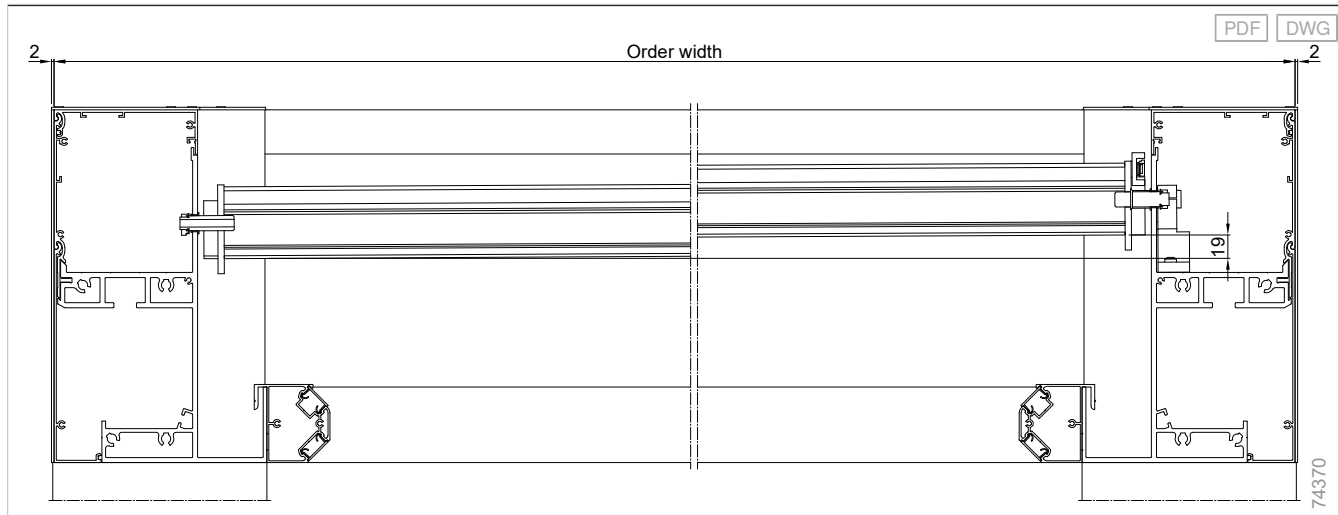

L60 Line, joint order width

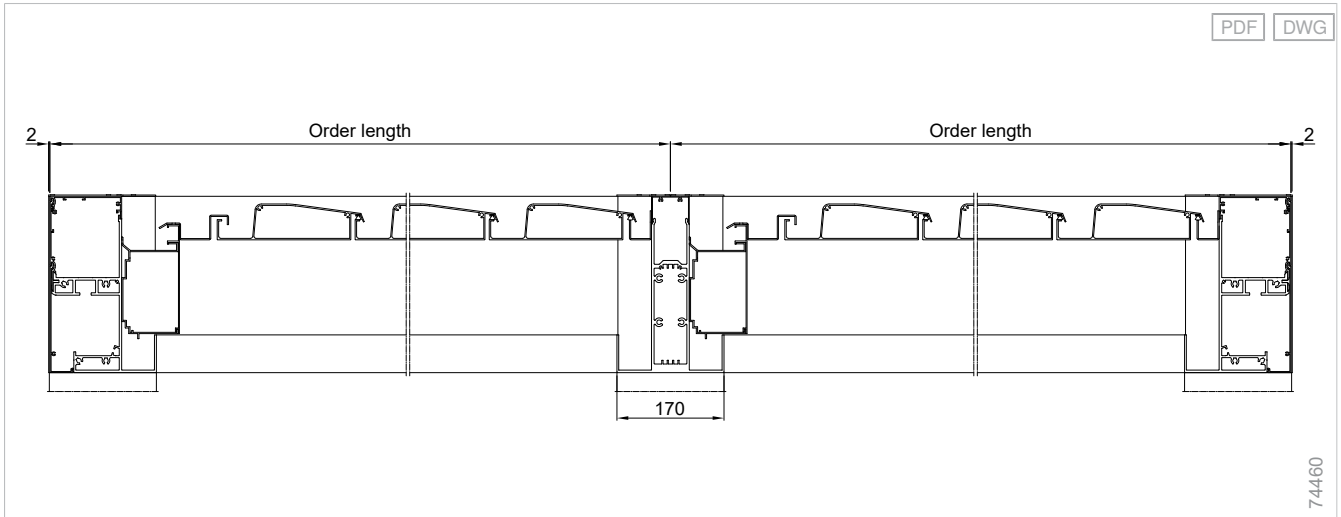

L60 Line, joint order length

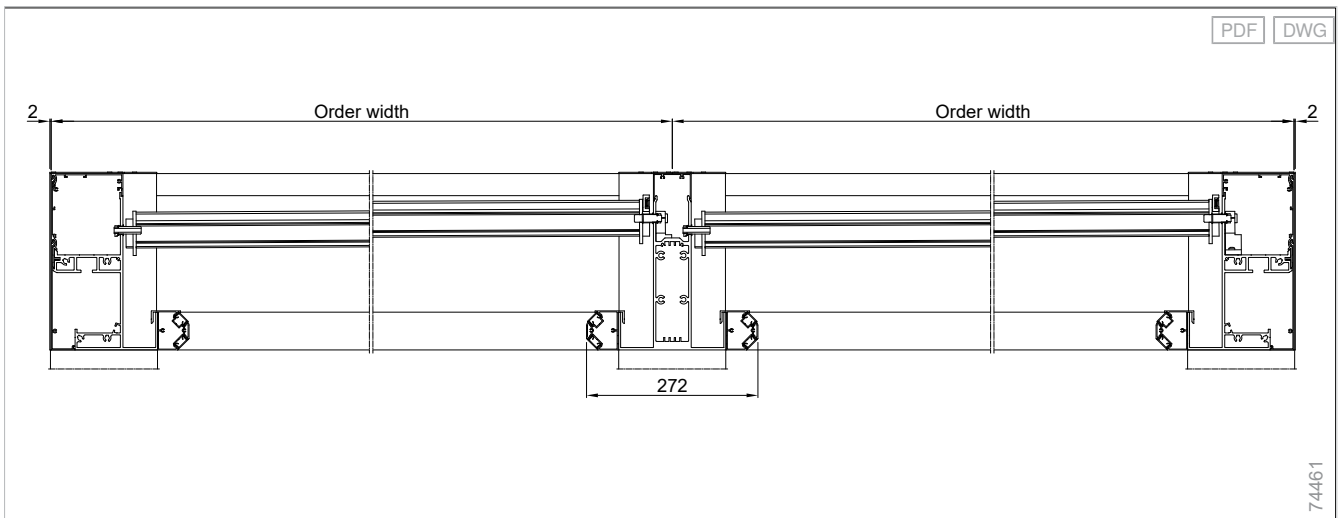

L60, length compensation plates, electrical distribution on crossbeam a

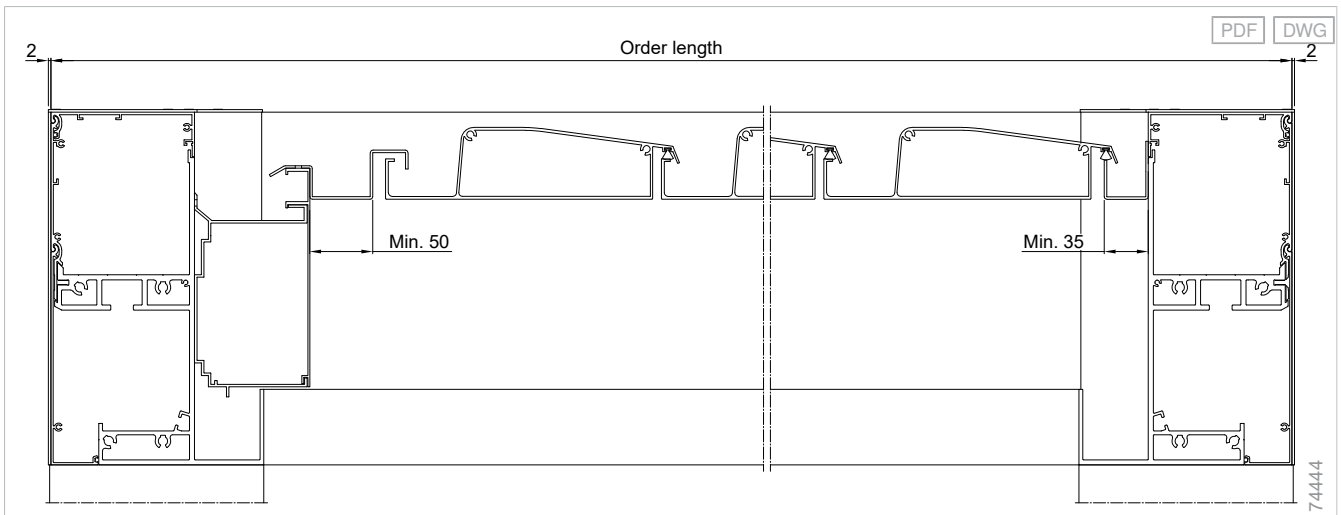

L60, length compensation plates, electrical distribution on crossbeam c

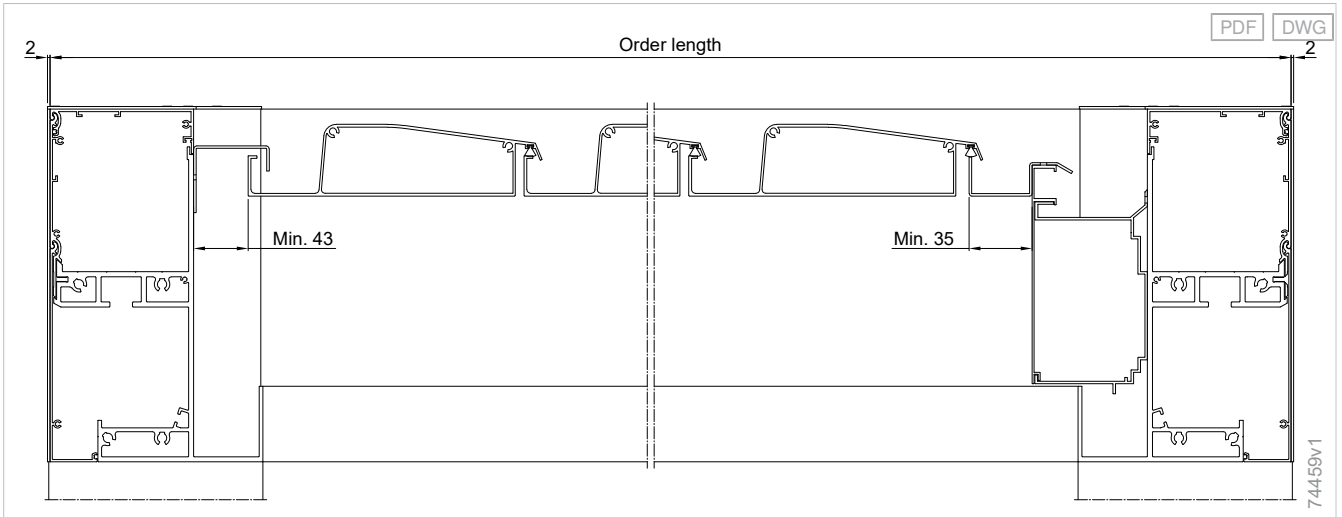

L60/L70, shim plate

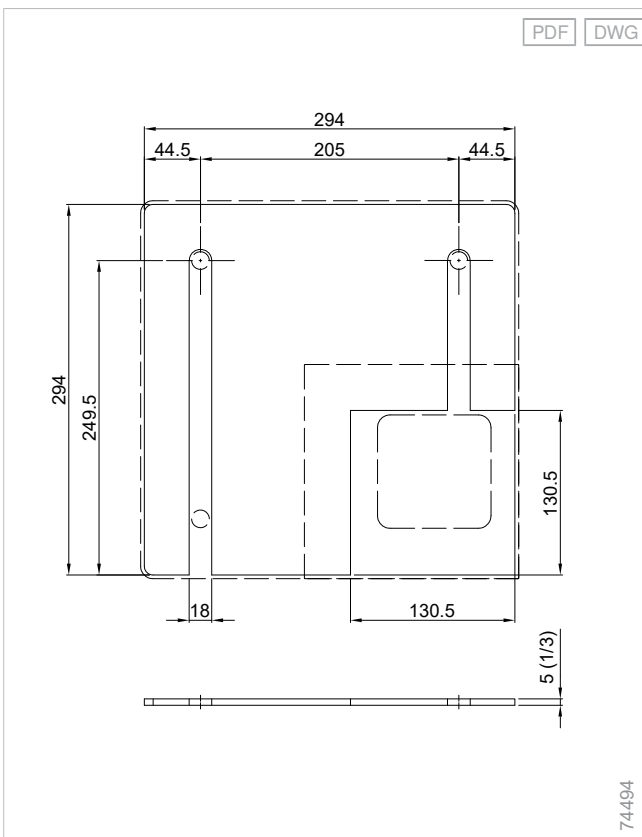

Planning

Slat roofs
Lamaxa

Glass roofs
Lamaxa

Fabric roofs
Lamaxa

Supplementary
accessories

Drive
variants

Standards

L60/L70, quarter shim plate

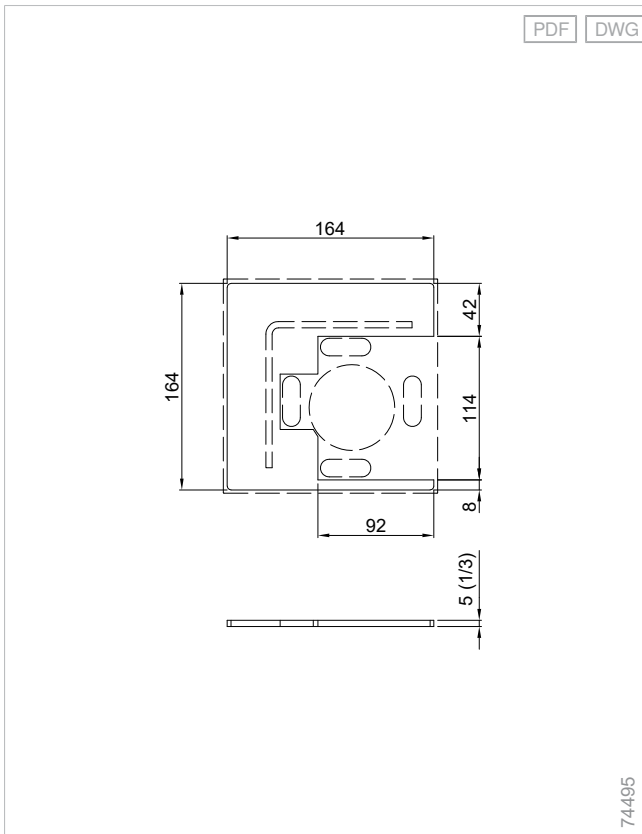

Additional product information

Pole installation options

Ground installation with frost-proof on-site foundation, see slat roof guidelines (IVRSA).

Mounting examples

Joint order width - Lamaxa Line L50/L60

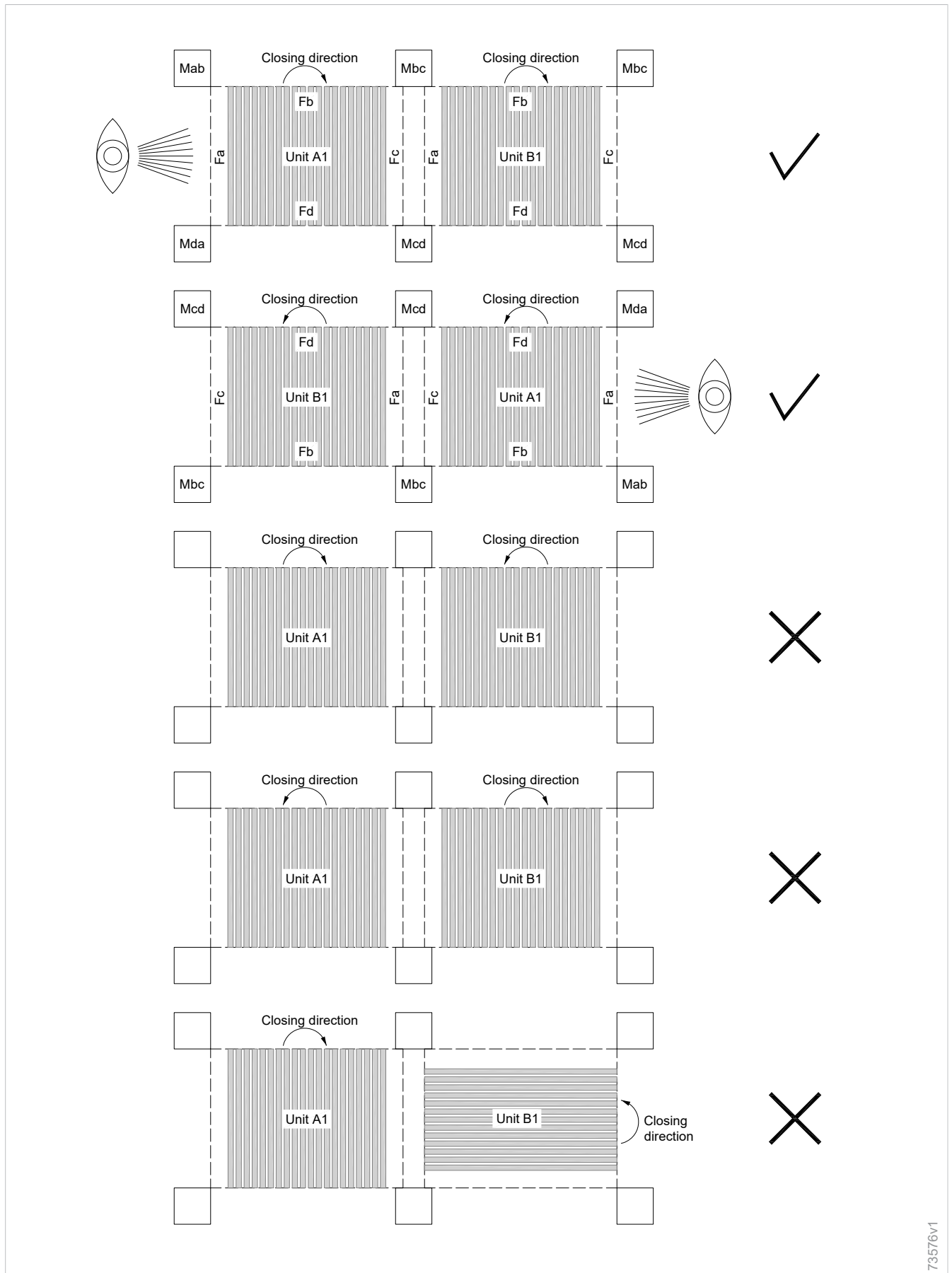

73576v1

Planning

Slat roofs
Lamaxa

Glass roofs
Lamaxa

Fabric roofs
Lamaxa

Supplementary
accessories

Drive
variants

Standards

Joint order length - Lamaxa Line L50/L60

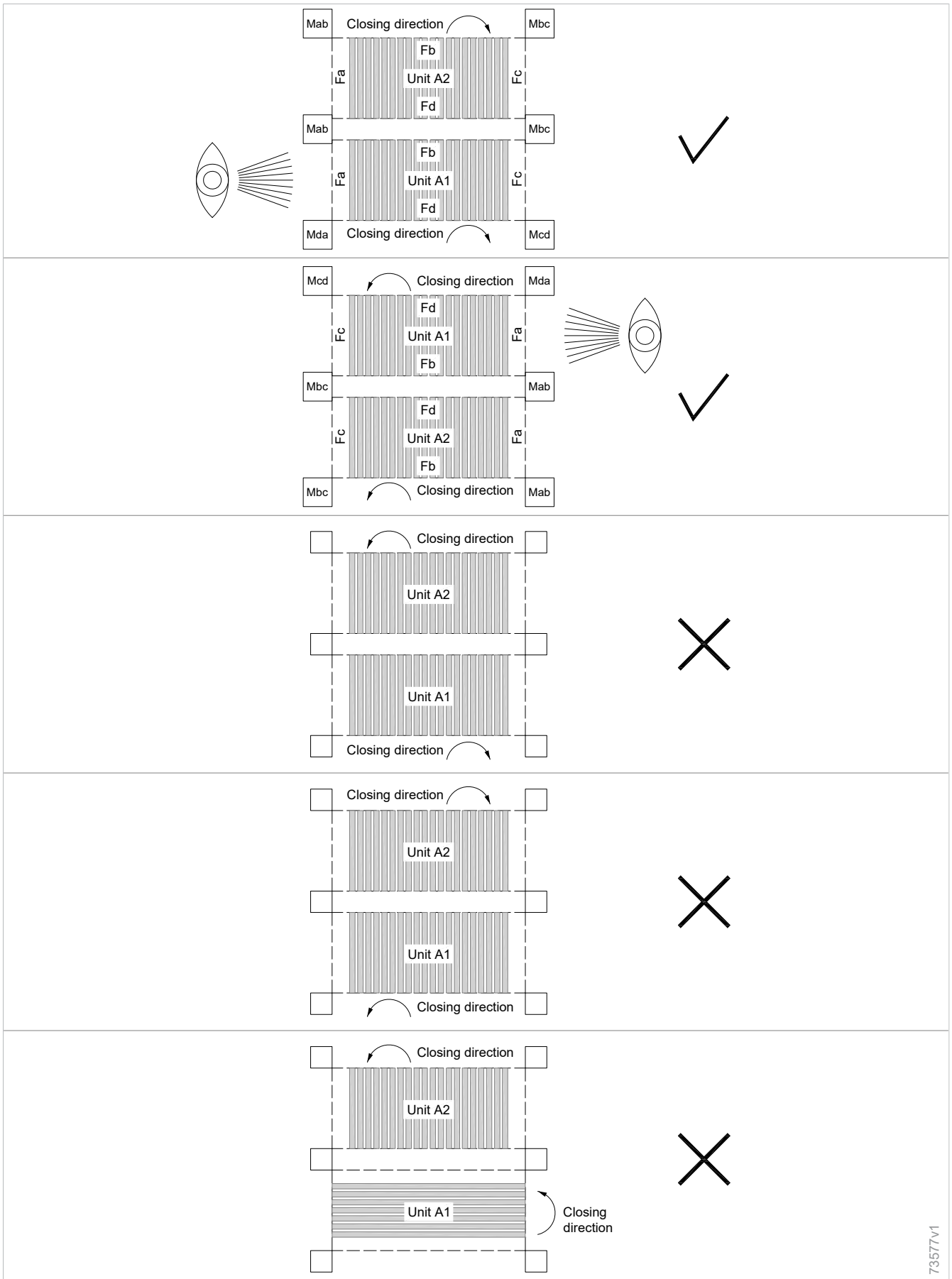

73577v1



Slat roofs Lamaxa

Slat roofs Lamaxa L50

Year-round use

Protection in all weather: Depending on the type, the incidence of light can be adjusted to various levels with the pivotable slats – all the way to a complete closure of the slat roof.

Clean

A clean appearance: The motor is perfectly integrated in the central aluminium slat.

Extendable

Reliable lateral visual privacy and wind protection: GranTex with easyZIP guidance can be installed on the top of any of the four Lamaxa sections for vertical shading.



Construction limit values

Maximum order width	4500 mm
Maximum order length	6020 mm
Maximum order area	27 m ²

Order here

myWAREMA

[Art.-Nr. 2040390](#)

WAREMA tools

[Sun Shading Planner](#)

[see "Navigating the document", Page 5](#)

Components

Slat roof Lamaxa L50

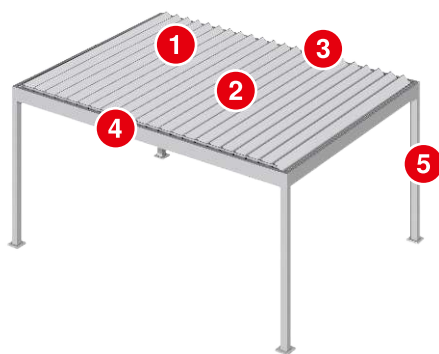

1	Slats	4	Tilting mechanism via push rod
2	Slat with motor	5	Pole
3	Crossbeam		

Slat

Slat - L50

Material	Aluminium, extruded
Surface	Powder-coated
Width	233 mm
Height	57 mm
Swivelling range	0 - 135 °

Pole

Pole - L50

Material	Aluminium, extruded
Surface	Powder-coated
Material, notes	one-piece
Width	110 mm
Height	110 mm

Installation options:

- Ground installation with frost-proof, on-site foundation.
- The grout for filling the clearance is not included in the scope of delivery when threaded rods are used.

Base plate

Base plate - L50

Material	Galvanised steel
Surface	Plain
Optional surface	Powder-coated
Width	200 mm
Height	200 mm

Crossbeam

Crossbeam - L50

Material	Aluminium, extruded
Surface	Powder-coated
Width	110 mm
Height	230 mm

Electrical distribution on the crossbeam, field c - L50

Material	Aluminium, folded
Surface	Powder-coated
Width	91,5 mm
Height	155 mm

Used as soon as one or more electronic accessory variants (e.g. LED strips, GranTex with easyZIP guidance) are selected. If no electronic accessories are selected, the connection is made by cable in the crossbeam.

Drainage

Drainage in pole - L50

- Drainage through drainpipe in pole.

Position of drainage outlet:

- Possible on every pole.
- Drainage and electronics/connecting lines must always be installed in separate poles.
- On the outsides of the poles or downward.
- Min. height.: 120 mm.
- Max. height: 200 mm below the headroom.

Wall connection profile, optional

Wall connection profile with small rain hood

Material	Aluminium, extruded
Surface	Powder-coated
Width	54 - 65 mm
Height	48 mm
Dimensions, notes	The adjustment range in the depth between rain hood and wall connection profile is up to 11 mm.

The on-site sealing is the responsibility of the specialist partner; if necessary, the commissioning of a plumbing company is recommended.

Field of application:

- Terrea K50
- Terrea K70
- Perea P20 (up to an angle of 10°)
- Lamaxa L50/L60/L70

Console, optional

Wall console - L50

Material	Galvanised steel
Surface	Powder-coated
Width	75 mm
Height	177 mm
Depth	105 mm

- Use in corner as pole replacement.
- A maximum of two poles can be replaced by wall consoles.
- For a concrete mounting substructure; adapter plates are required for other substructures.
- The wall console protrudes 8 mm beyond the order width and order length. This results in a gap of 8 mm between the crossbeam and the wall.

Drive variants

- Motor

Motor

- WMS-LP (WMS)

⊕ see "Drive variants", Page 201

Colours

- WAREMA Colour World, Individual category, fine texture surface quality
- WAREMA Colour World, Highlight category, fine texture surface quality
- WAREMA Colour World, Variation category, fine texture surface quality

Colours, optional:

- WAREMA Colour World

⊕ see "Colours and finishes", Page 10

Construction limit values

Configuration variants	Minimum order width	Maximum order width	Minimum order length	Maximum order length	Maximum order area	Minimum headroom	Maximum headroom
Slat							
Slat - L50	2500 mm	4500 mm	2000 mm	6020 mm	27 m ²	800 mm	2700 mm

Following enquiry, deviations from the standard construction limit values are possible (within limits).

Pole height:

- Minimum height for poles with drainage: 800 mm.
- Minimum height for poles without drainage: 800 mm.
- The maximum pole height (headroom plus floor recess) is ≤ 3000 mm.

Notes

Limit position learning:

The WAREMA Smart programming cable is required in order to adjust the motor limit positions.

Number of optional extras per field:

Only one optional extra is possible per field. Either GranTex with easyZIP guidance, LED on the poles, sliding shutters with wooden or aluminium filling or the SL20e glass sliding system.

Supplementary accessories

- Design radiant heater
- GranTex with easyZIP guidance
- Glass sliding system SL20e
- Sliding shutters - L50/L60/L70
- Lamaxa lighting
- Protection profile
- Additional pole - L50
- Offset pole - L50/L50 Tex
- Power socket

⊕ see "Supplementary accessories", Page 143

Dimension determination

The headroom of each pole can be ordered individually (e.g. in case of a sloping finished floor).

Field definition - L50

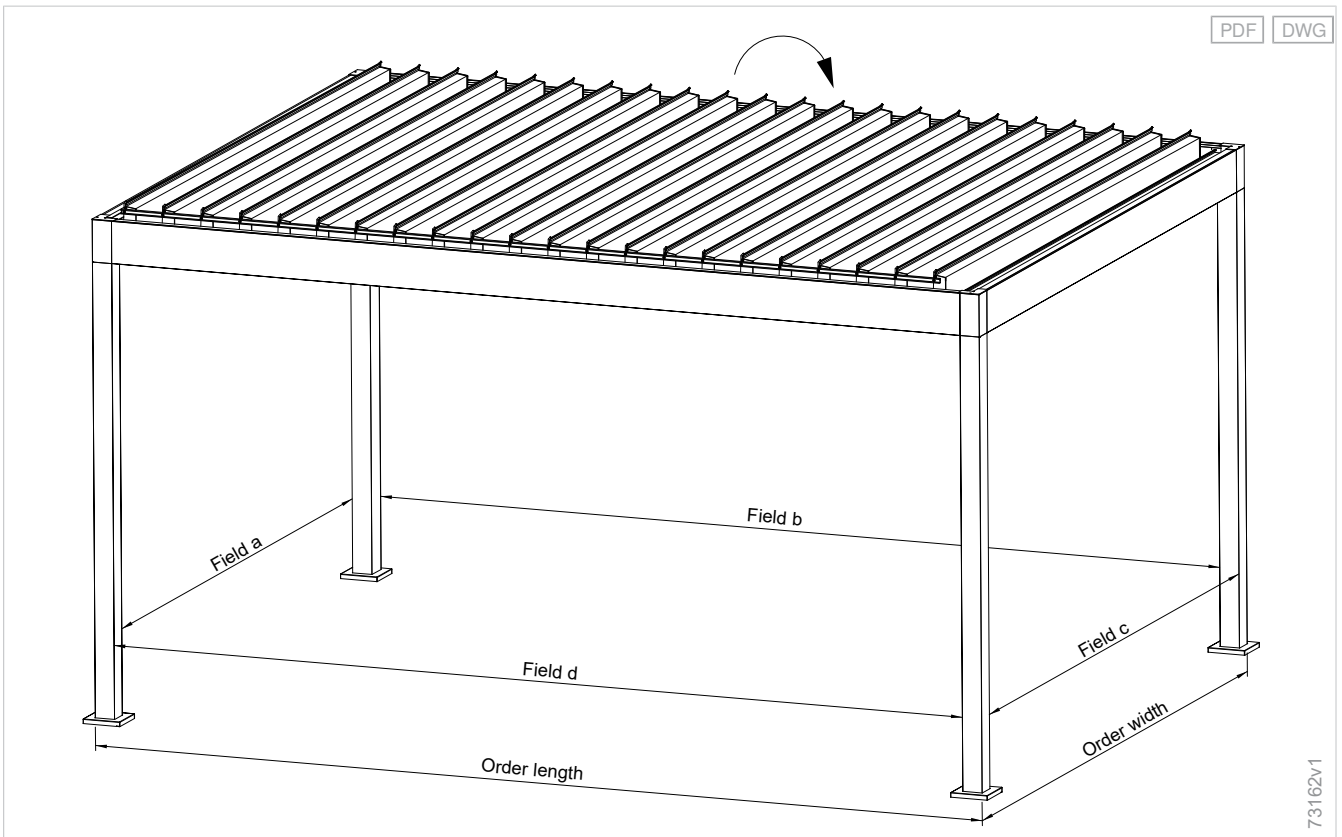

Planning

Slat roofs
Lamaxa

Glass roofs
Lamaxa

73162v1

Top view of the position/connection points - L50/L60/L70

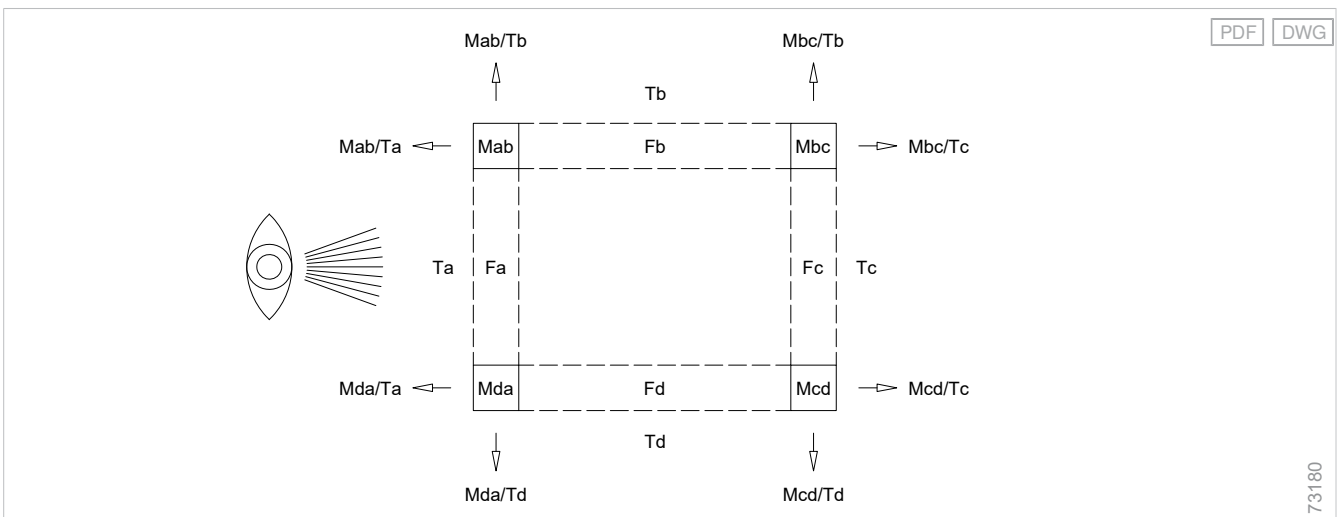

Fabric roofs
Lamaxa

Supplementary
accessories

73180

- F Field
M Point of installation (pole or wall connection)

T Crossbeam

Drive
variants

Standards

Side view with open slats - L50

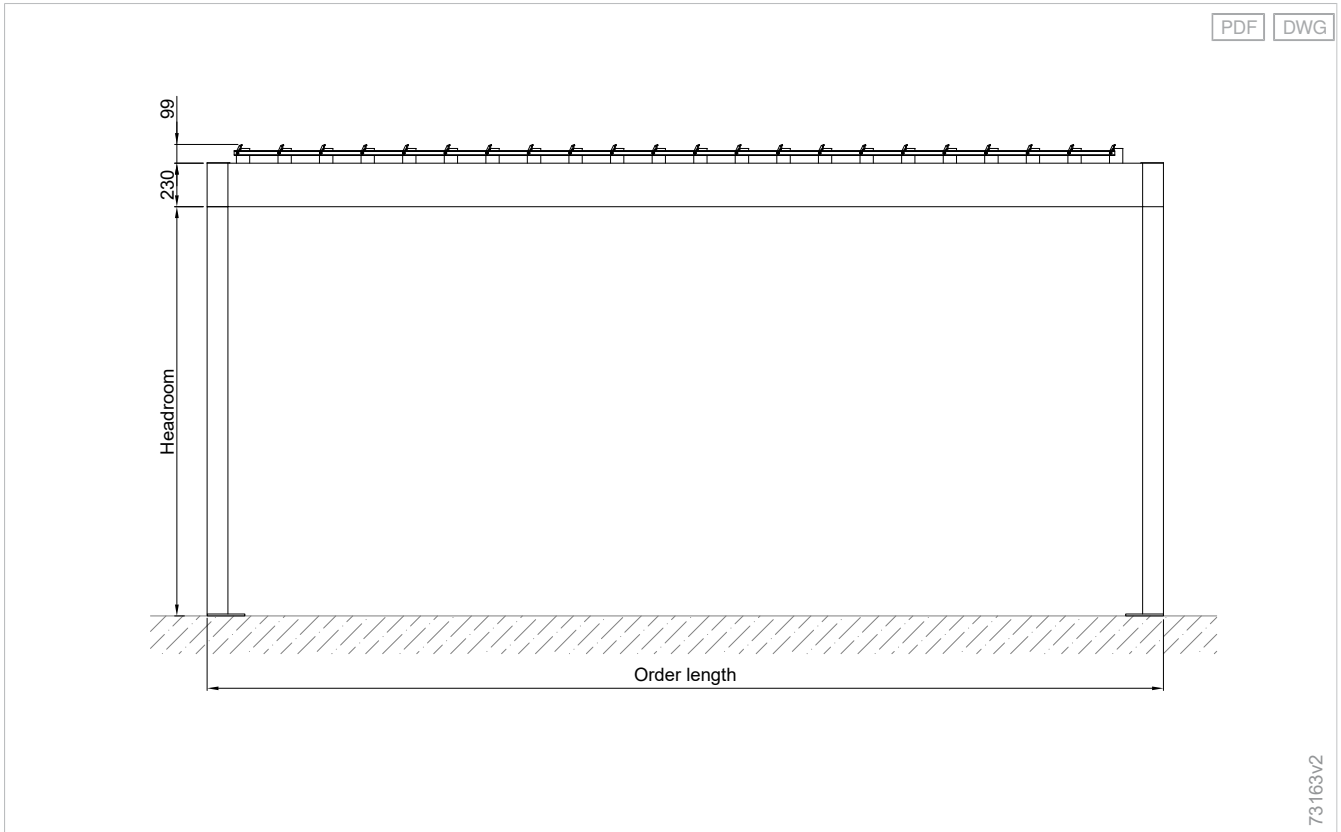

When closed, the slats do not protrude beyond the crossbeam.

Side view of wall connection with wall console - L50

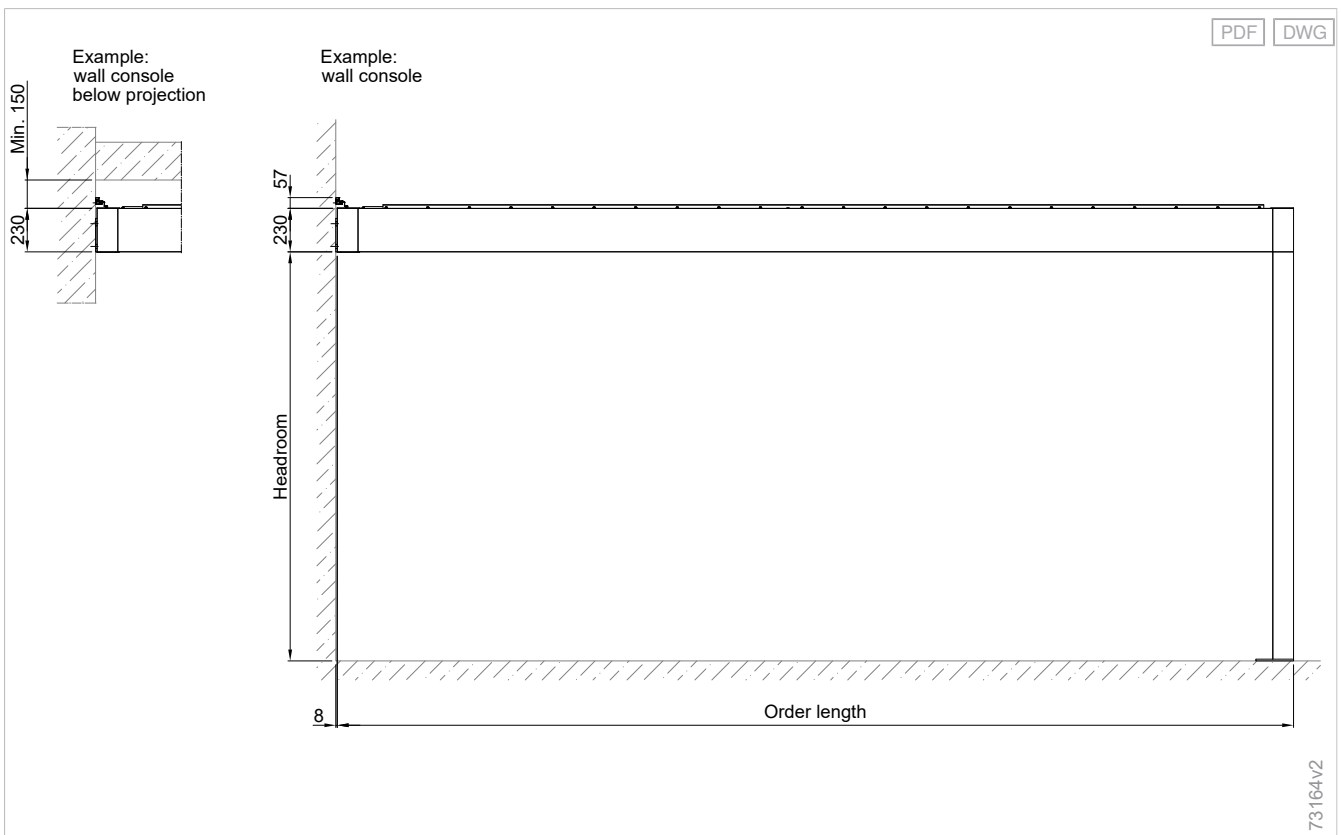

Optimal order length - L50 individual unit

Order length in mm	Number of slats
2000	7
2060	8
2280	9
2500	10
2720	11
2940	12
3160	13
3380	14
3600	15
3820	16
4040	17
4260	18
4480	19
4700	20
4920	21
5140	22
5360	23
5580	24
5800	25
6020	26

Planning

Slat roofs
Lamaxa

Glass roofs
Lamaxa

The order length in the table is the dimension with the smallest possible length compensation plates and therefore corresponds to the optimum order dimension (except order length 2000 mm) for individual units. For the calculation of the optimal order length for series-mounted units, please use the following sketches for L50 Line dimension determination.

Weight assessment

Weight assessment for roof systems

Order length	Order width				
	2500 mm	3000 mm	3500 mm	4000 mm	4500 mm
2000 - 2500 mm	252 kg	277 kg	302 kg	328 kg	353 kg
2501 - 3000 mm	277 kg	305 kg	334 kg	363 kg	392 kg
3001 - 3500 mm	302 kg	334 kg	366 kg	399 kg	431 kg
3501 - 4000 mm	335 kg	373 kg	411 kg	448 kg	486 kg
4001 - 4500 mm	360 kg	402 kg	443 kg	484 kg	525 kg
4501 - 5000 mm	385 kg	430 kg	475 kg	520 kg	564 kg
5001 - 5500 mm	419 kg	469 kg	519 kg	569 kg	619 kg
5501 - 6020 mm	444 kg	498 kg	551 kg	605 kg	659 kg

Fabric roofs
Lamaxa

Supplementary
accessories

Drive
variants

Standards

Details

L50/L60 slats

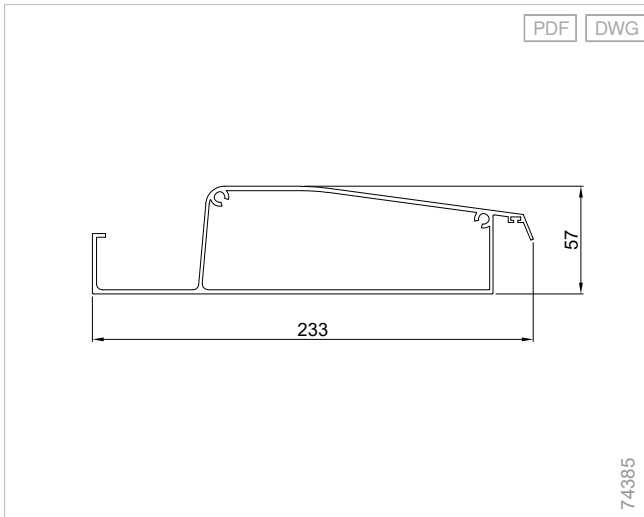

Tilting mechanism via push rod - L50/L60

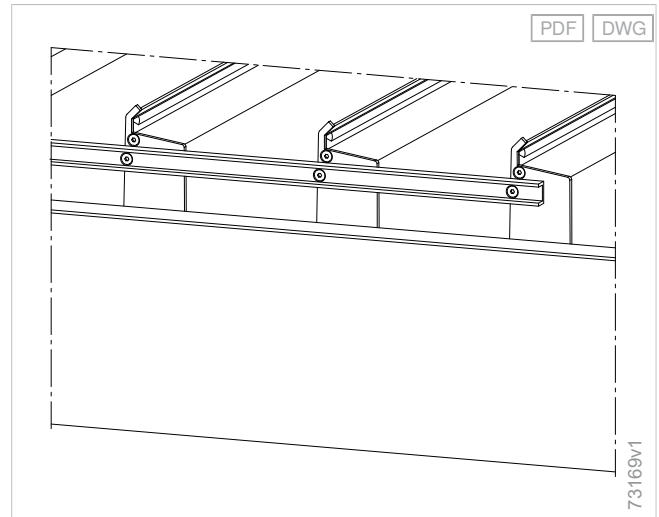

Crossbeam - L50

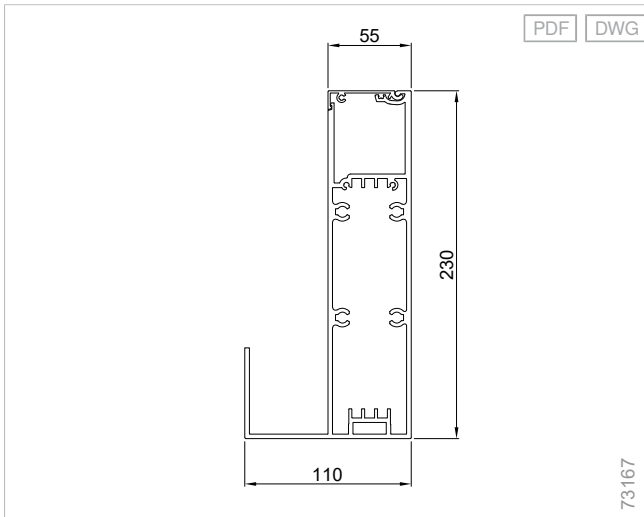

In case of the L50 the push rod is always positioned opposite the drainage. The position of the push rod can be selected for L60.

Pole - L50

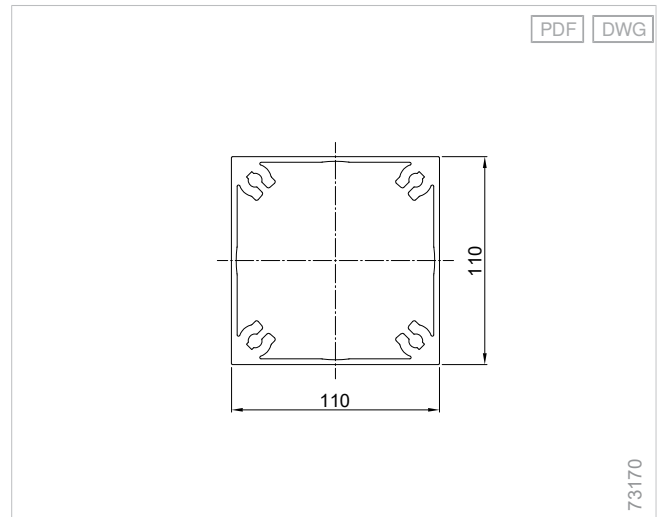

Crossbeam with LED profile - L50

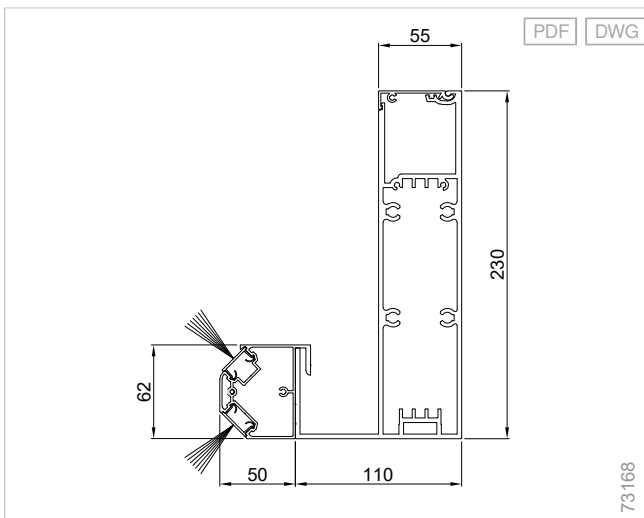

Base plate - L50

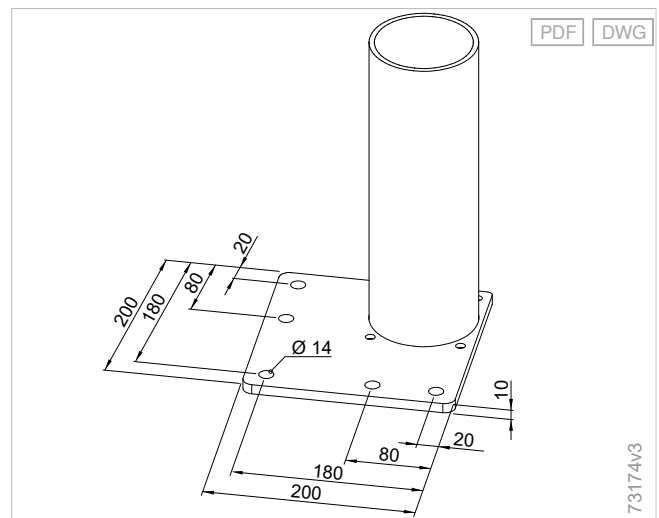

L50, rectangular drainage

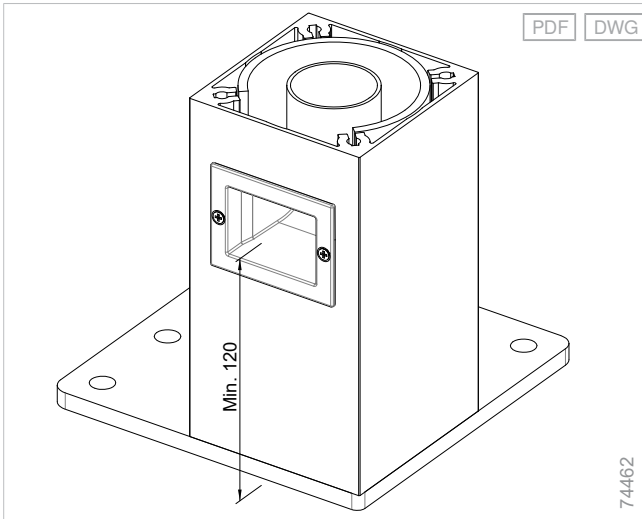

L50, rectangular drainage, optional waterspout

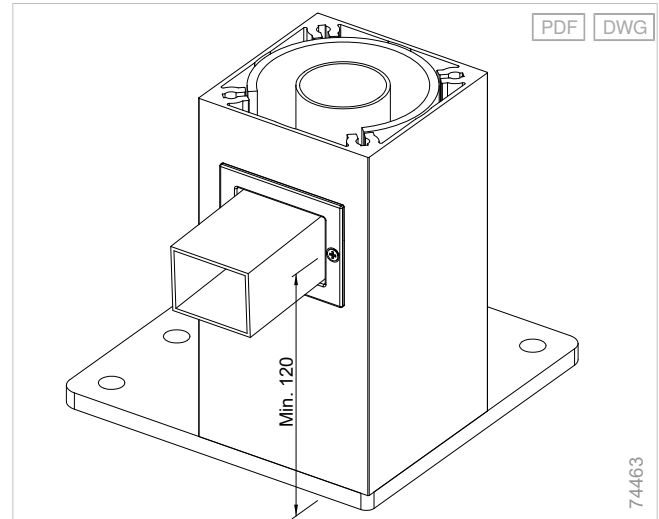

L50, position of drainage, on-site

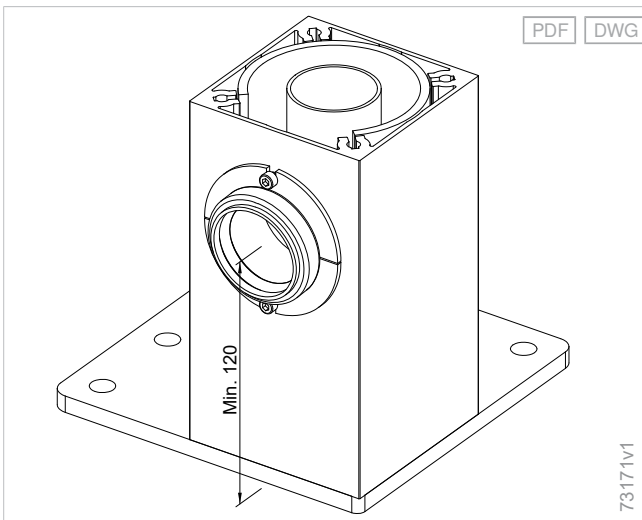

Length comparison (with connection box) - L50

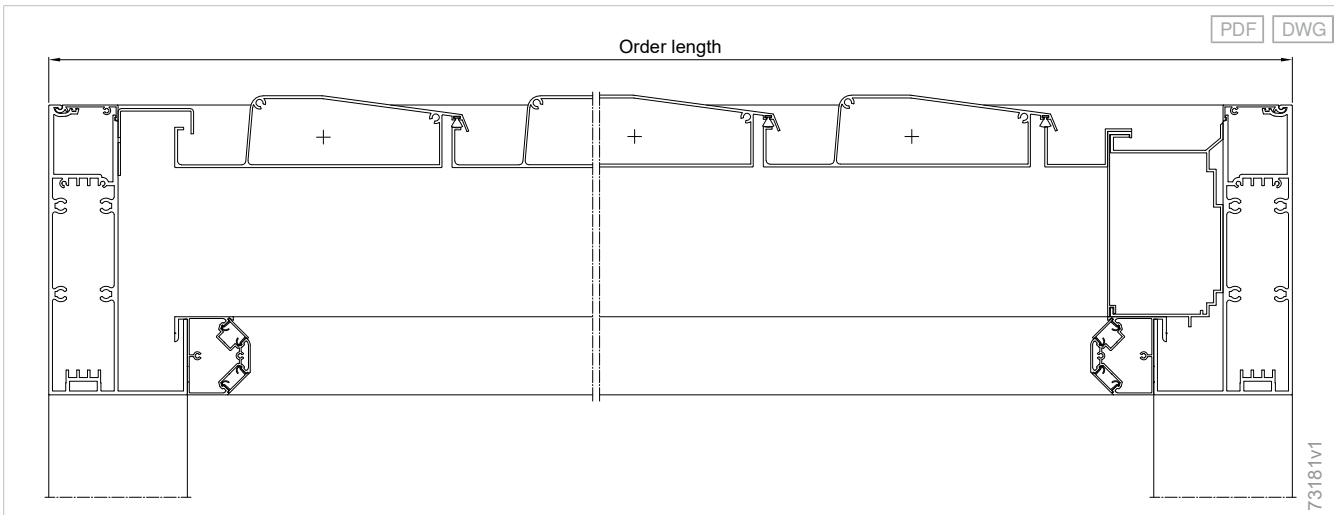

Planning

Slat roofs
Lamaxa

Glass roofs
Lamaxa

Fabric roofs
Lamaxa

Supplementary
accessories

Drive
variants

Standards

External base cover - L50

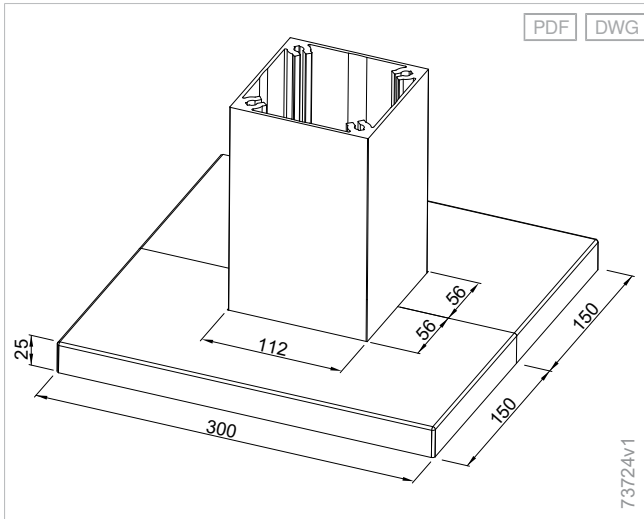

73724v1

Recess installation base cover - L50

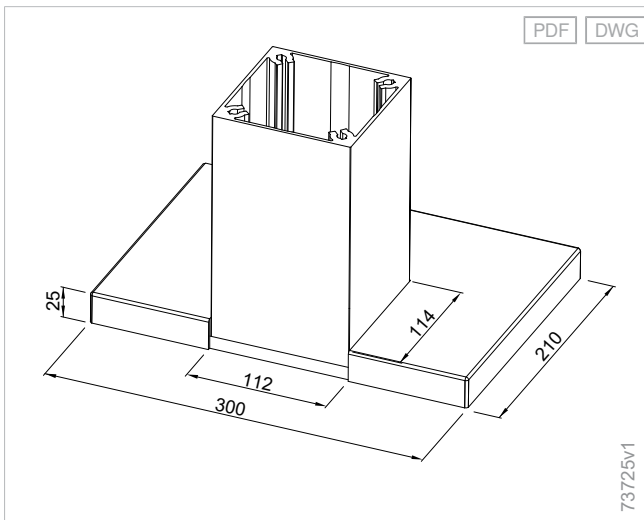

73725v1

Corner installation base cover - L50

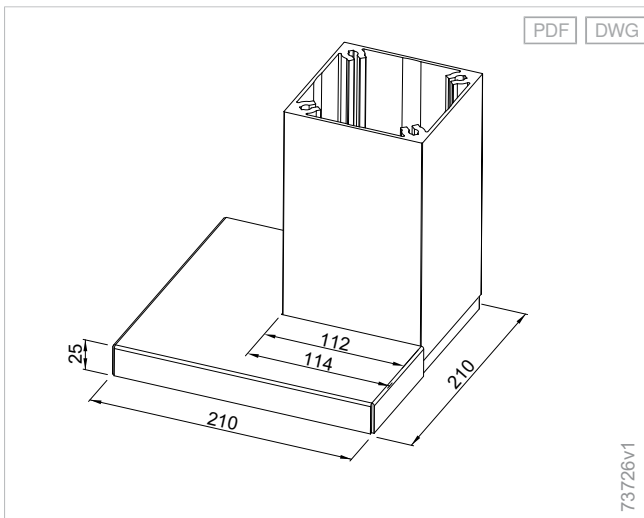

73726v1

Console wall connection L50

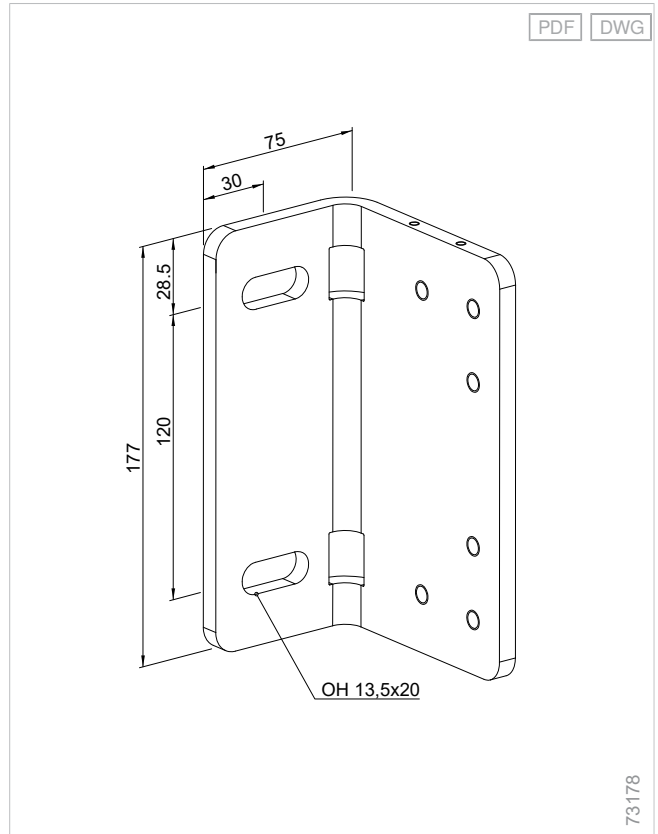

73178

Lateral wall console facing - L50

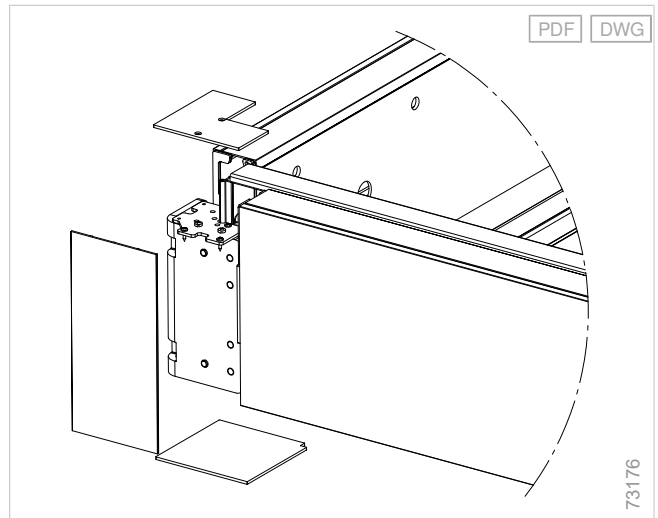

73176

Inner angle wall console facing - L50

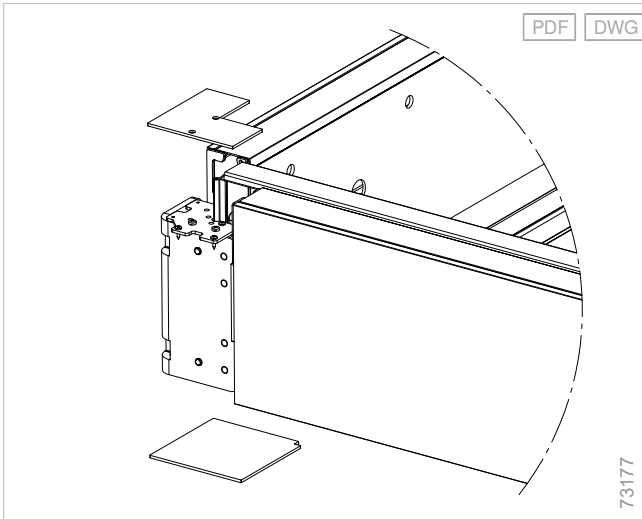

Wall connection profile with small rain hood - L50/L60/L70

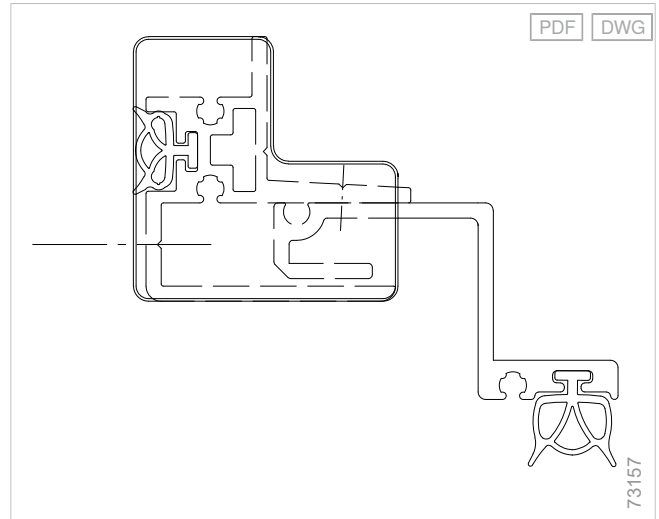

Additional product information

Pole installation options

Ground installation with frost-proof on-site foundation, see slat roof guidelines (IVRSA).

Mounting examples

Application of base plate for recess installation - L50

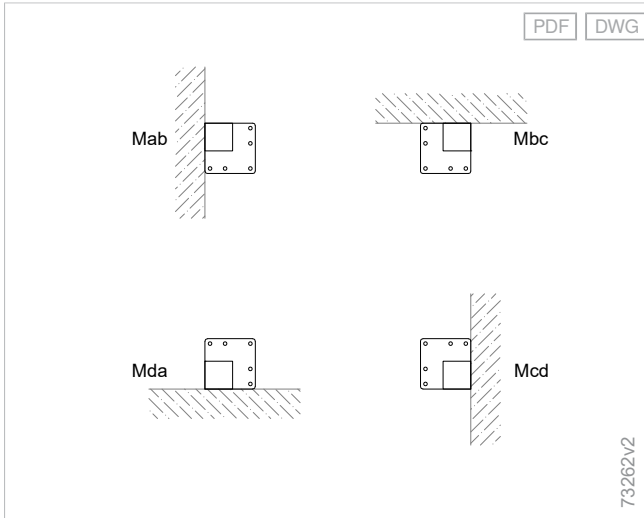

M Point of installation (pole or wall connection)

Application of corner installation base plate - L50

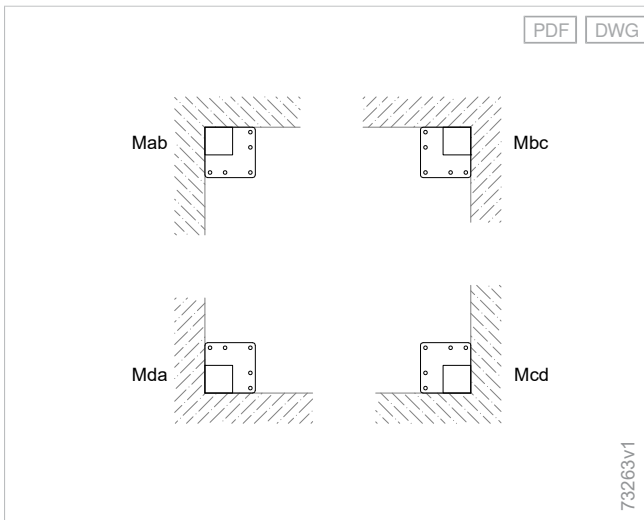

M Point of installation (pole or wall connection)

Fixing on concrete foundation

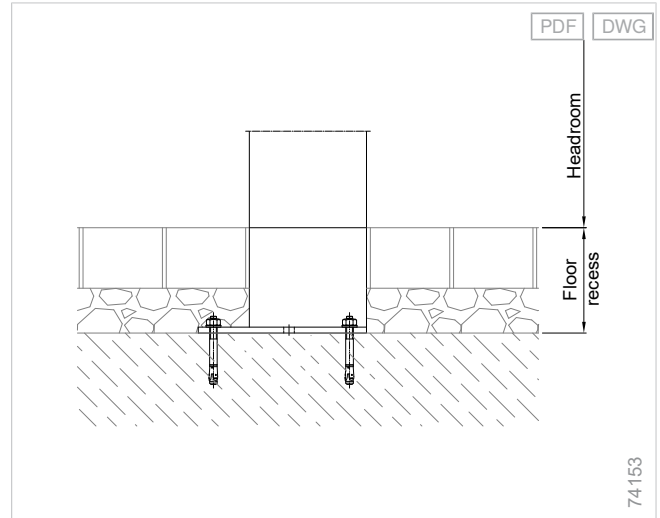

Fixing on concrete foundation (corner installation)

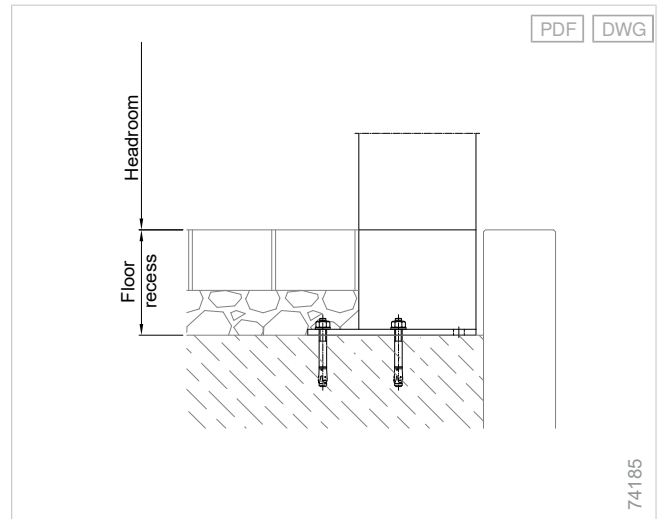

Side view of wall connection - L50

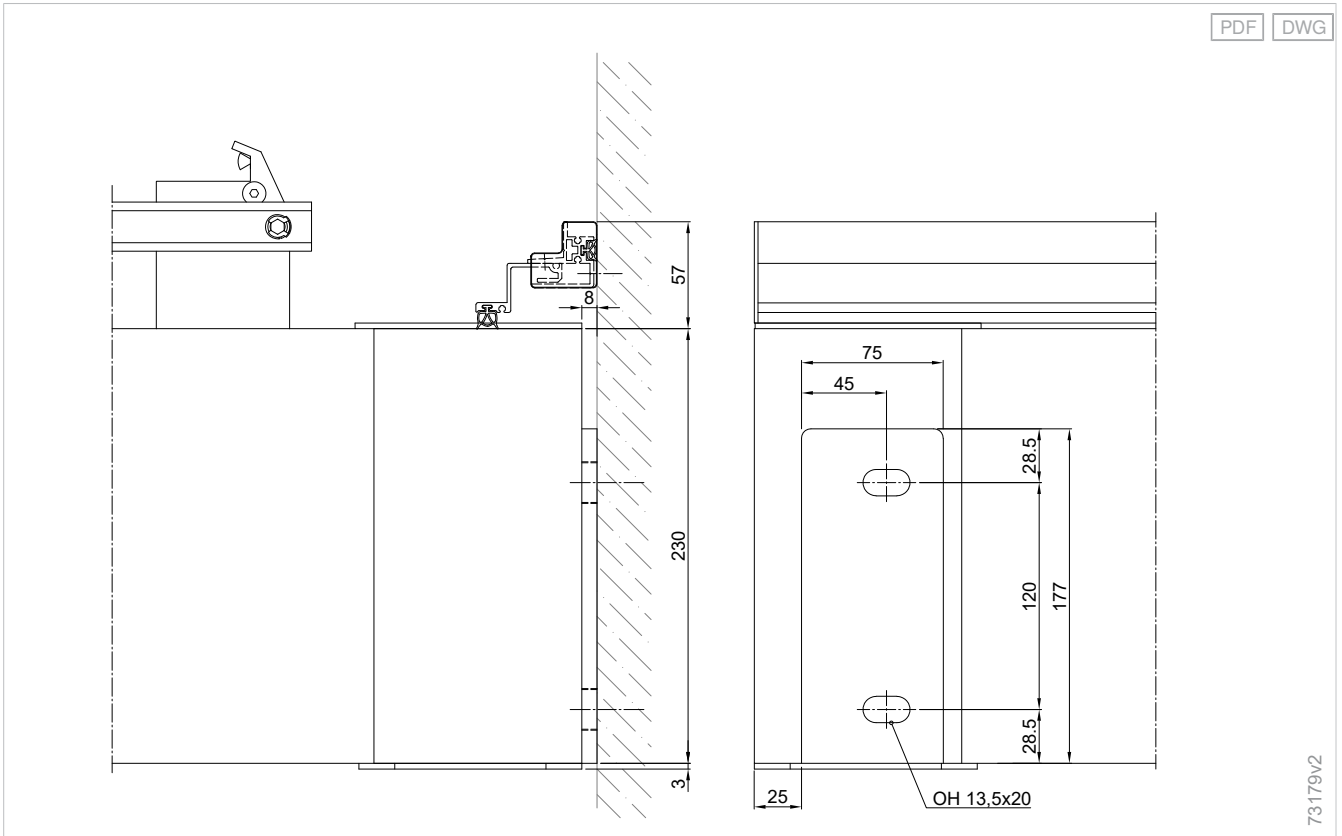

Design radiant heater on crossbeam - L50

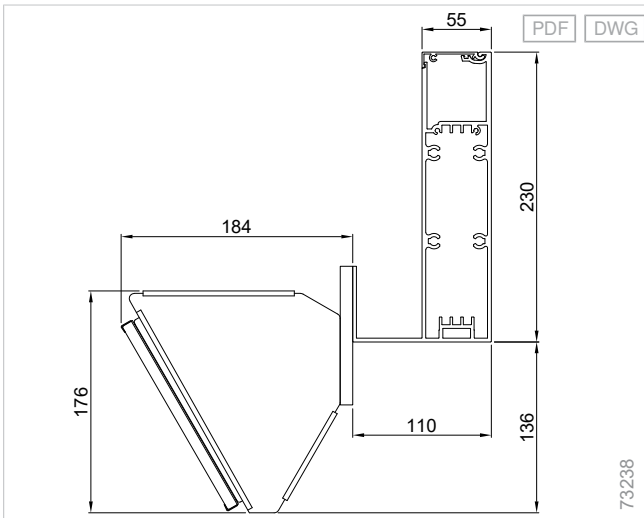

Planning

Slat roofs
Lamaxa

Glass roofs
Lamaxa

Fabric roofs
Lamaxa

Supplementary
accessories

Drive
variants

Standards



Slat roofs Lamaxa

Slat roofs Lamaxa L50 Line

Expansive

Shade very large areas flexibly: With a central pole, several roof systems can be elegantly lined up along the long as well as the short side. Free-standing, with wall connection or in a star shape.

Inviting

Perfect for the catering sector: Plenty of space at all times with an inviting flair for outdoor guests – in the open air or appropriately protected from the sun and rain.

Versatile

Protection in all weather: Depending on the type, the incidence of light can be adjusted to various levels with the pivotable slats – all the way to a complete closure of the slat roof.

Construction limit values

Maximum order width	27000 mm
Maximum order length	36000 mm
Maximum order area	162 m ²

Order here

myWAREMA

[Art.-Nr. 2056682](#)

WAREMA tools

[Sun Shading Planner](#)

[+ see "Navigating the document", Page 5](#)

Components

Lamaxa Line - L50

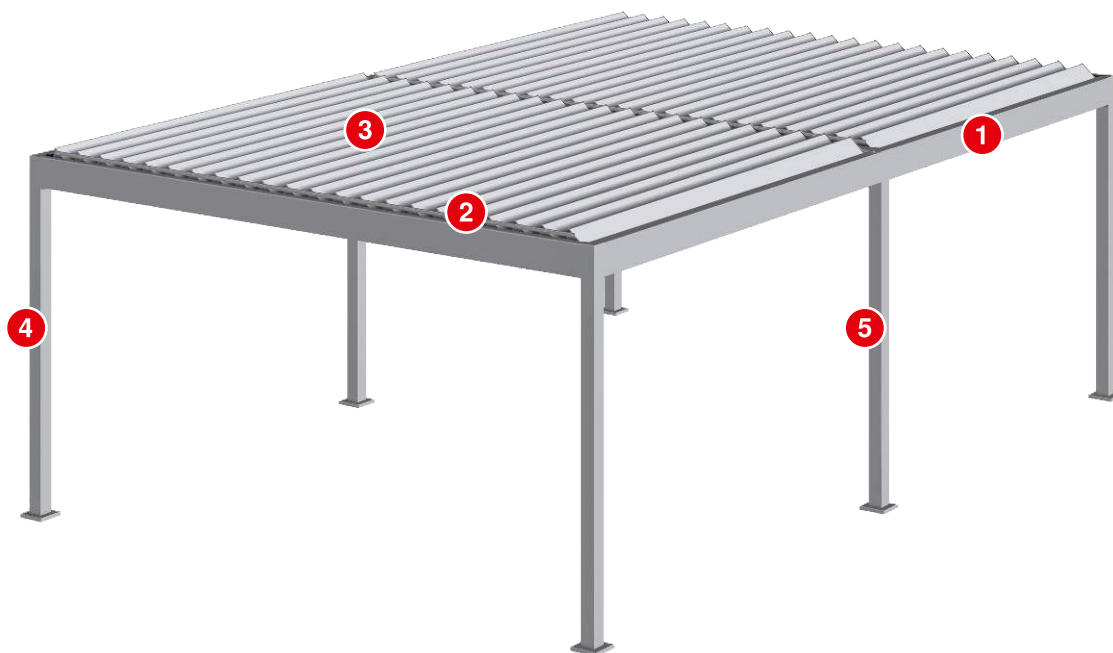

- 1 Crossbeam
- 2 Tilting mechanism via push rod
- 3 Slat with motor

- 4 Pole
- 5 Middle pole

Lamaxa star system - L50

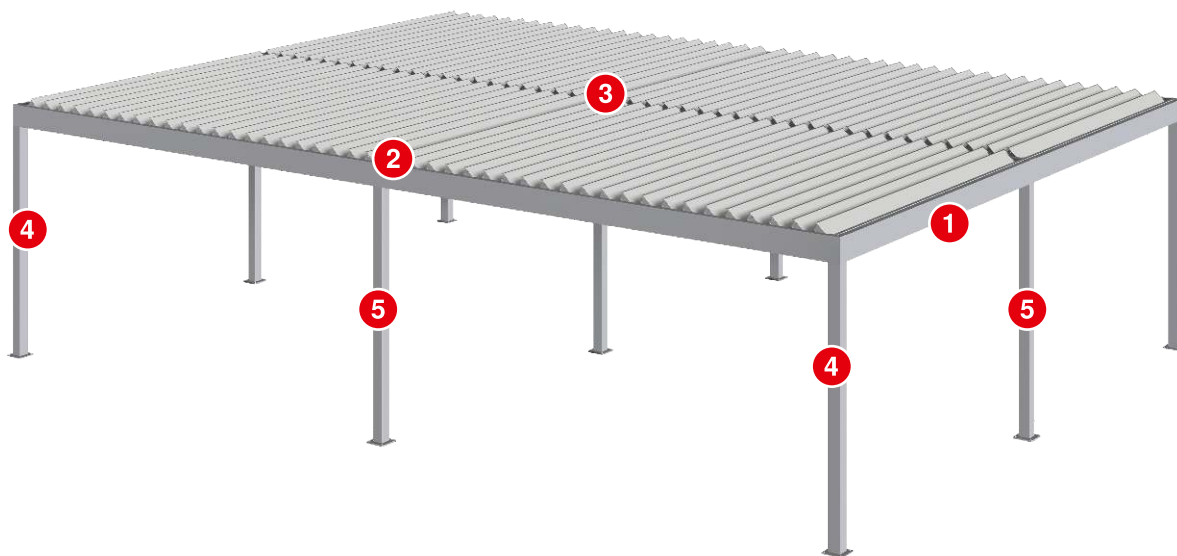

- 1 Crossbeam
- 2 Tilting mechanism via push rod
- 3 Slats

- 4 Pole
- 5 Middle pole

Planning

Slat roofs
Lamaxa

Glass roofs
Lamaxa

Fabric roofs
Lamaxa

Supplementary
accessories

Drive
variants

Standards

Slat

Slat - L50

Material	Aluminium, extruded
Surface	Powder-coated
Width	233 mm
Height	57 mm
Swivelling range	0 - 135 °

Pole

Pole - L50

Material	Aluminium, extruded
Surface	Powder-coated
Material, notes	one-piece
Width	110 mm
Height	110 mm

Installation options:

- Ground installation with frost-proof, on-site foundation.
- The grout for filling the clearance is not included in the scope of delivery when threaded rods are used.

Centre pole - L50 Line

Material	Aluminium, extruded
Surface	Powder-coated
Width	110 mm
Height	110 mm

Base plate

Base plate - L50

Material	Galvanised steel
Surface	Plain
Optional surface	Powder-coated
Width	200 mm
Height	200 mm

Crossbeam

Crossbeam - L50

Material	Aluminium, extruded
Surface	Powder-coated
Width	110 mm
Height	230 mm

Electrical distribution on the crossbeam, field c - L50

Material	Aluminium, folded
Surface	Powder-coated
Width	91,5 mm
Height	155 mm

Used as soon as one or more electronic accessory variants (e.g. LED strips, GranTex with easyZIP guidance) are selected. If no electronic accessories are selected, the connection is made by cable in the crossbeam.

Middle crossbeam - L50 Line

Material	Aluminium, extruded
Surface	Powder-coated
Width	165 mm
Height	230 mm

Drainage

Drainage point in pole - L50 Line

- Drainage through drainpipe in pole
- In order to achieve rain class 2 with an individual unit with closed slats, at least two drainage points are required for a system size > 16 m².
- For a total area of up to 54 m², three drainage points are sufficient to comply with rain class 2.
- In the case of a star system consisting of at least 4 roof crowns (2x2), only a restricted rain class can be achieved, as rain class 2 can no longer be achieved due to design limitations.

Position of drainage outlet:

- Possible on every pole
- Drainage and electronics/connecting lines must always be installed in separate poles.
- On the outsides of the poles or downward
- Min. height.: 120 mm
- Max. height: 200 mm below the headroom

Wall connection profile, optional

Wall connection profile with small rain hood

Material	Aluminium, extruded
Surface	Powder-coated
Width	54 - 65 mm
Height	48 mm
Dimensions, notes	The adjustment range in the depth between rain hood and wall connection profile is up to 11 mm.

The on-site sealing is the responsibility of the specialist partner; if necessary, the commissioning of a plumbing company is recommended.

Field of application:

- Terrea K50
- Terrea K70
- Perea P20 (up to an angle of 10°)
- Lamaxa L50/L60/L70

Console, optional

Wall console - L50

Material	Galvanised steel
Surface	Powder-coated
Width	75 mm
Height	177 mm
Depth	105 mm

- Use in corner as pole replacement.
- A maximum of two poles can be replaced by wall consoles.
- For a concrete mounting substructure; adapter plates are required for other substructures.
- The wall console protrudes 8 mm beyond the order width and order length. This results in a gap of 8 mm between the crossbeam and the wall.

Drive variants

- Motor

Motor

- WMS-LP (WMS)

+ see "Drive variants", Page 201

Colours

- WAREMA Colour World, Highlight category, fine texture surface quality
- WAREMA Colour World, Variation category, fine texture surface quality

Colours, optional:

- WAREMA Colour World

+ see "Colours and finishes", Page 10

Notes

Limit position learning:

The WAREMA Smart programming cable is required to set the motor limit positions.

Operation and control:

To ensure comfortable and fast operation of the slat roof, we recommend WMS WebControl pro (control via smartphone, tablet, etc.) and WMS Weather station plus in order to use the control modes (e.g. sun control). To do so, a sufficiently strong radio reception must be ensured.

Number of optional extras per field:

Only one optional extra is possible per field. Either GranTex with easyZIP guidance, LED on the poles, sliding shutters with wooden or aluminium filling or the SL20e glass sliding system.

Series-mounted units:

- Generally, unit coupling (drive coupling) is not possible.
- Flush closures allow two slat roofs to be centrally mounted in-series on one common pole.
- The two slat roofs can be matched to the order width or order length (L50 Line) or to the order width and order length (L50 star unit).
- The matched roofs all close in the same direction.
- The motor is always positioned in the same place. The connecting rod is therefore always located on the same side of the crossbeam for all roofs.
- The order length or order width is dimensioned to the centre axis of the centre pole.
- The wall console can be used at any mounting point. The number of wall consoles must not exceed the number of poles.
- If the middle mounting point is selected as the wall console, a wall console is used to seat 3 crossbeams.
- The mounting of a GranTex with easyZIP guidance or LED on any side of the pole is possible. Neither is possible below the double crossbeam.
- RGB lighting of both units can be learned in to an RGB hand-held transmitter.

+ see "Planning requirements - L50 Line and Star unit", Page 23

Supplementary accessories

- Design radiant heater
- Lamaxa lighting
- GranTex with easyZIP guidance
- Glass sliding system SL20e
- Sliding shutters - L50/L60/L70
- Additional pole - L50
- Protection profile
- Power socket

+ see "Supplementary accessories", Page 143

Construction limit values

Configuration variants	Minimum order width	Maximum order width	Minimum order length	Maximum order length	Maximum order area	Minimum headroom	Maximum headroom
Slat							
Slat - L50	2500 mm	27000 mm	2000 mm	36000 mm	162 m ²	800 mm	2700 mm

Dimension determination

The headroom of each pole can be ordered individually (e.g. in case of a sloping finished floor).

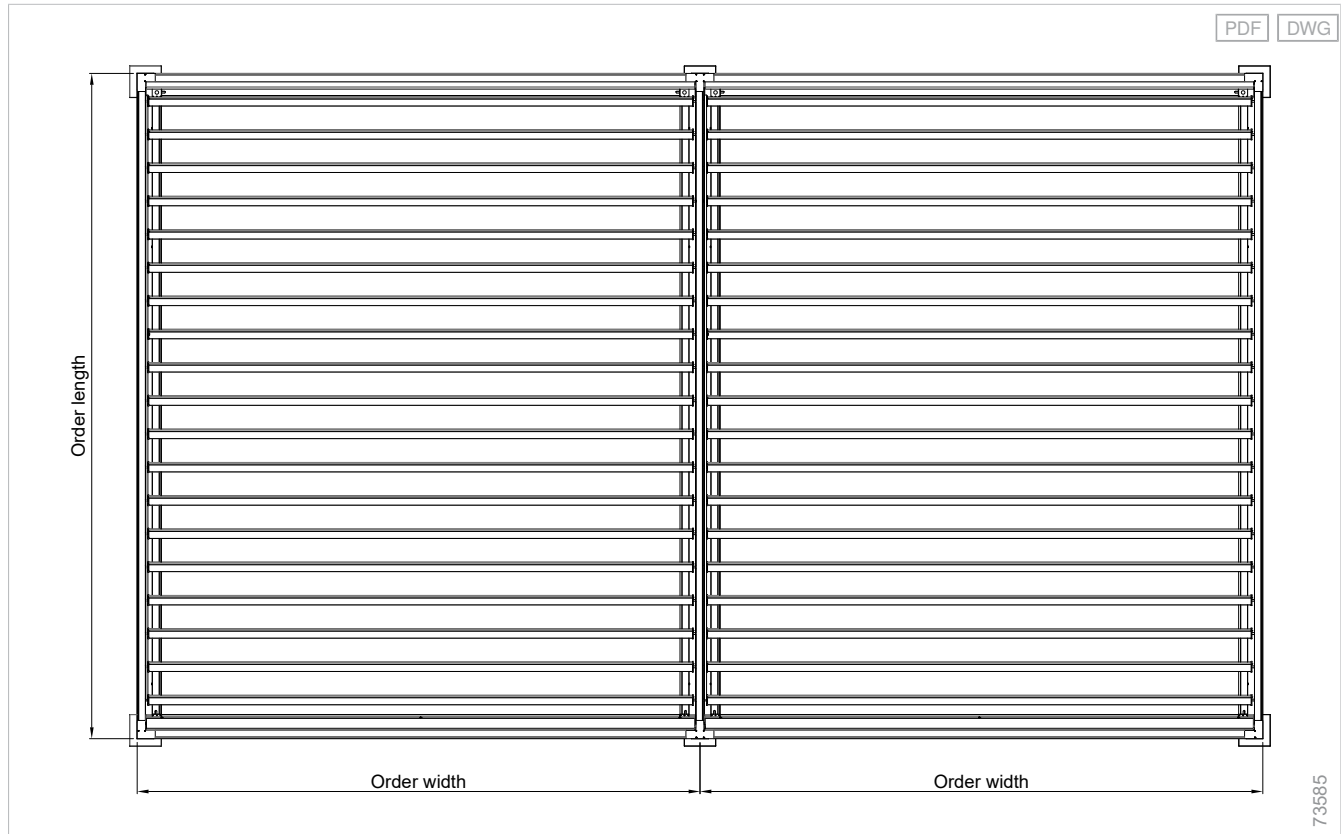

Top view of the position/connection points - Lamaxa Line L50/L60/L70

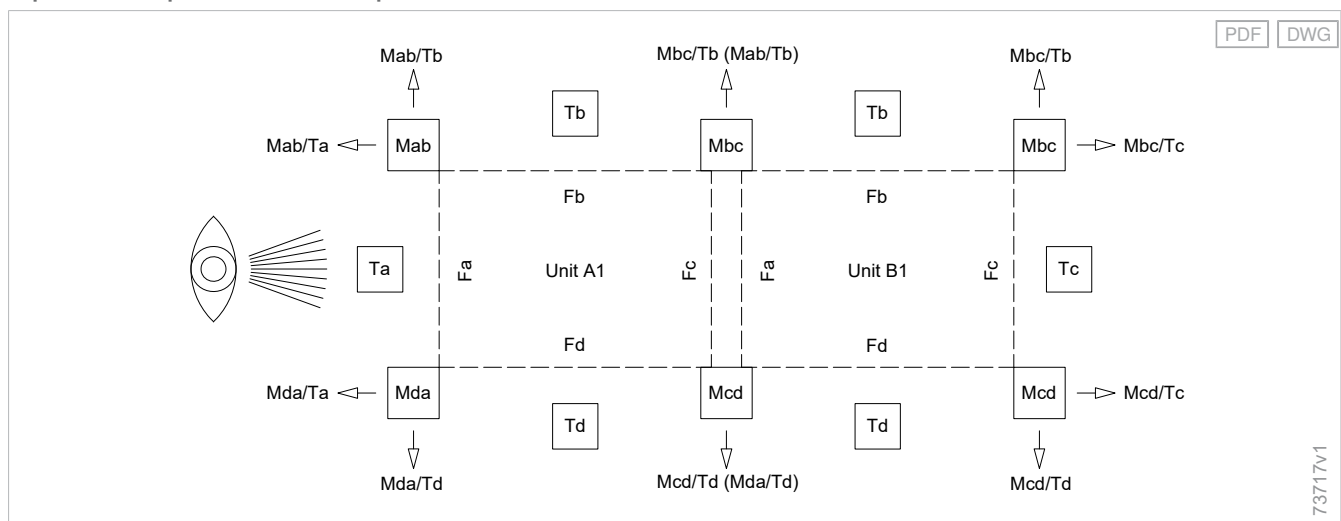

- F Field
- M Point of installation (pole or wall connection)
- T Crossbeam

Top view of the position/connection points - Lamaxa Line L50/L60/L70

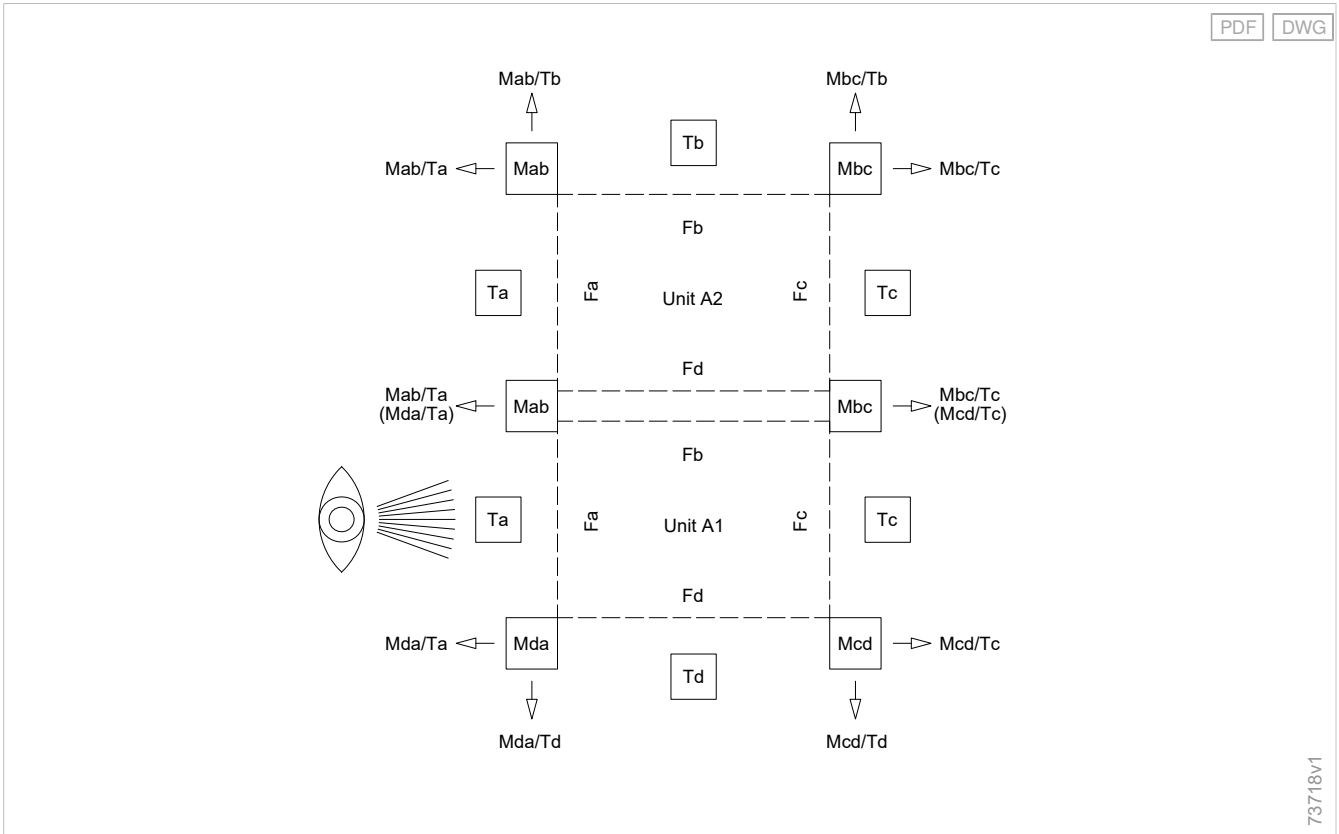

Planning

Slat roofs
Lamaxa

Glass roofs
Lamaxa

Side view of wall connection with wall console - L50

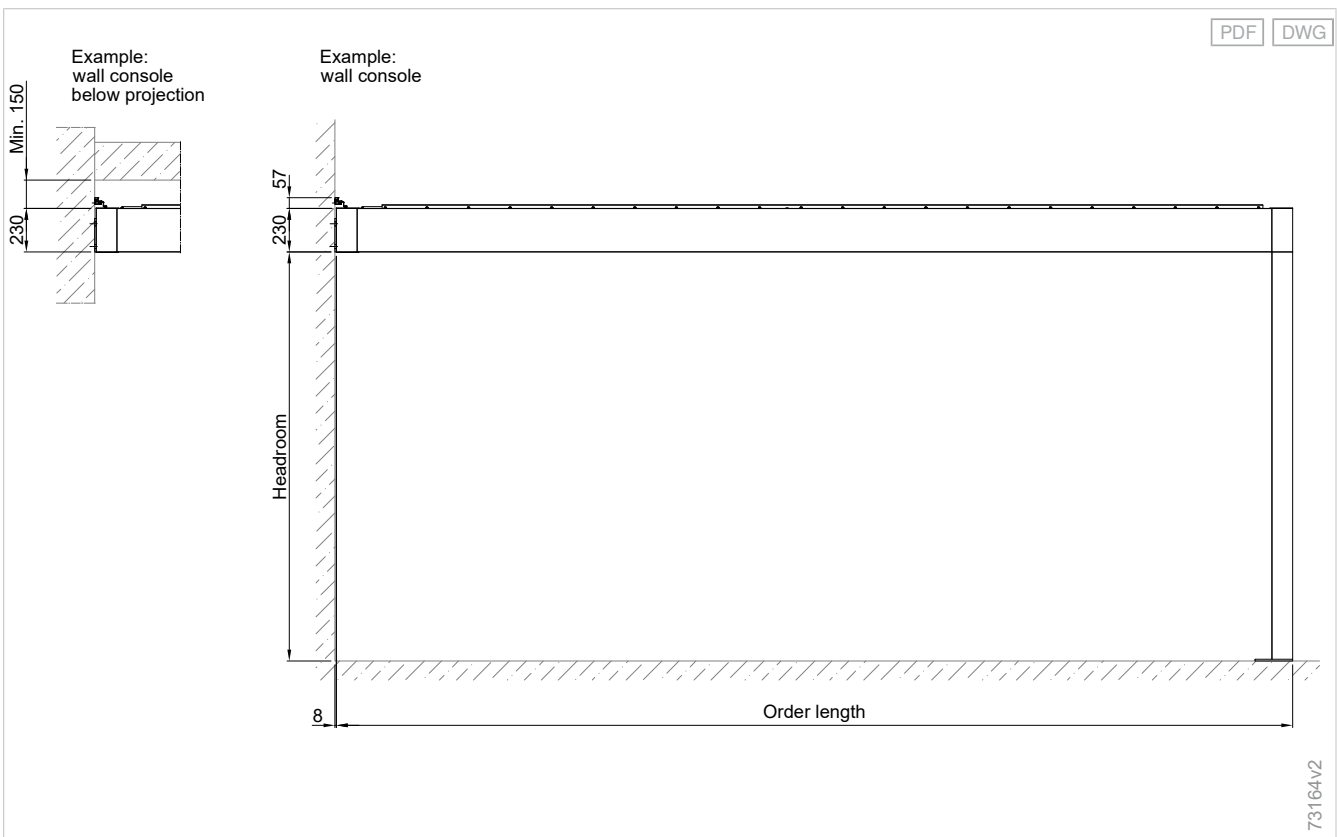

Fabric roofs
Lamaxa

Supplementary
accessories

Drive
variants

Standards

Optimum order length - Lamaxa L50 Line/star unit

System X: Order length in mm	System Y: Order length in mm	Number of slats
2033	2005	8
2253	2225	9
2473	2445	10
2693	2665	11
2913	2885	12
3133	3105	13
3353	3325	14
3573	3545	15
3793	3765	16
4013	3985	17
4233	4205	18
4453	4425	19
4673	4645	20
4893	4865	21
5113	5085	22
5333	5305	23
5553	5525	24
5773	5745	25
5993	5965	26
6000	6000	26

The order length in the table is the dimension with the smallest possible length compensation plates and corresponds to the optimum order dimension (except order length 6000 mm). To determine the optimal order length for the L50 Line and star units, please use the following sketches for dimension determination.

L50 Line - 2 units

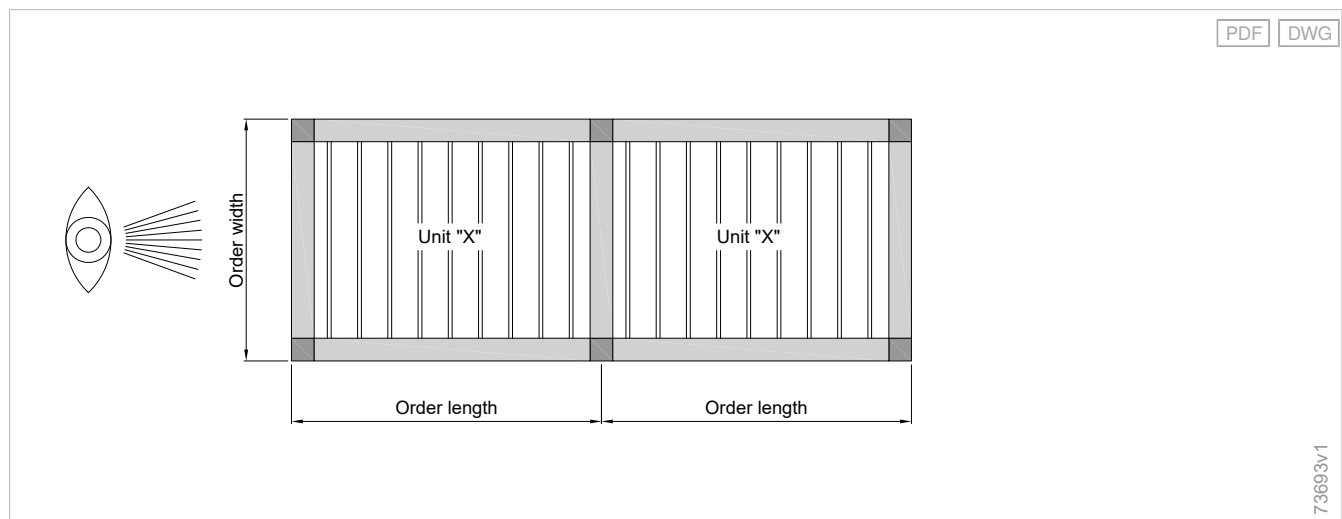

L50 Line - 3 to 6 units

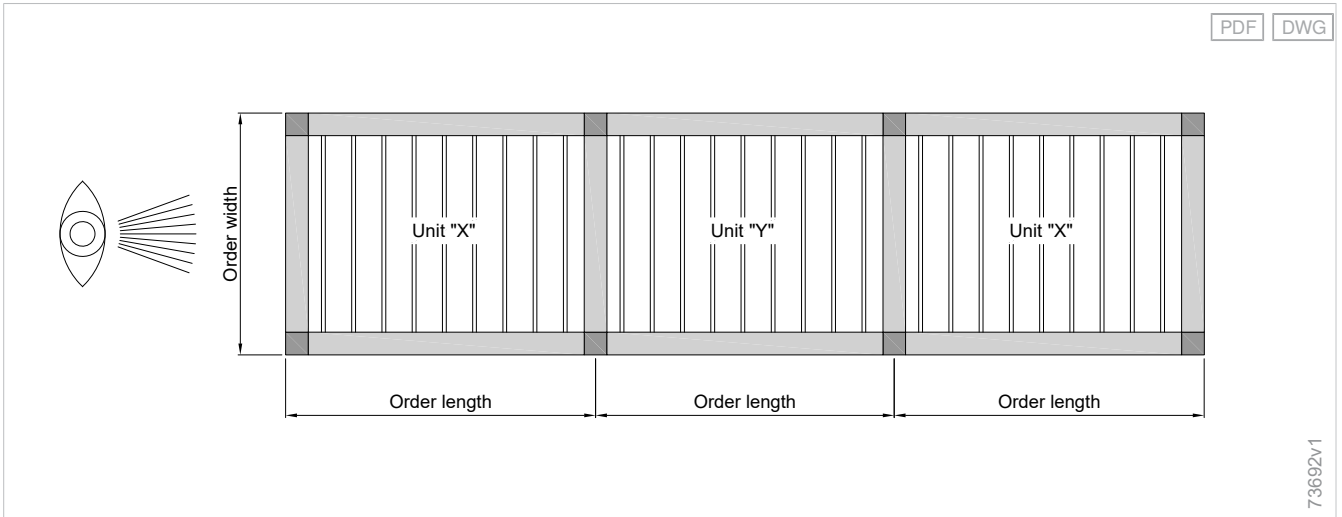

Planning

Slat roofs
Lamaxa

Details

Length comparison (with connection box) - L50

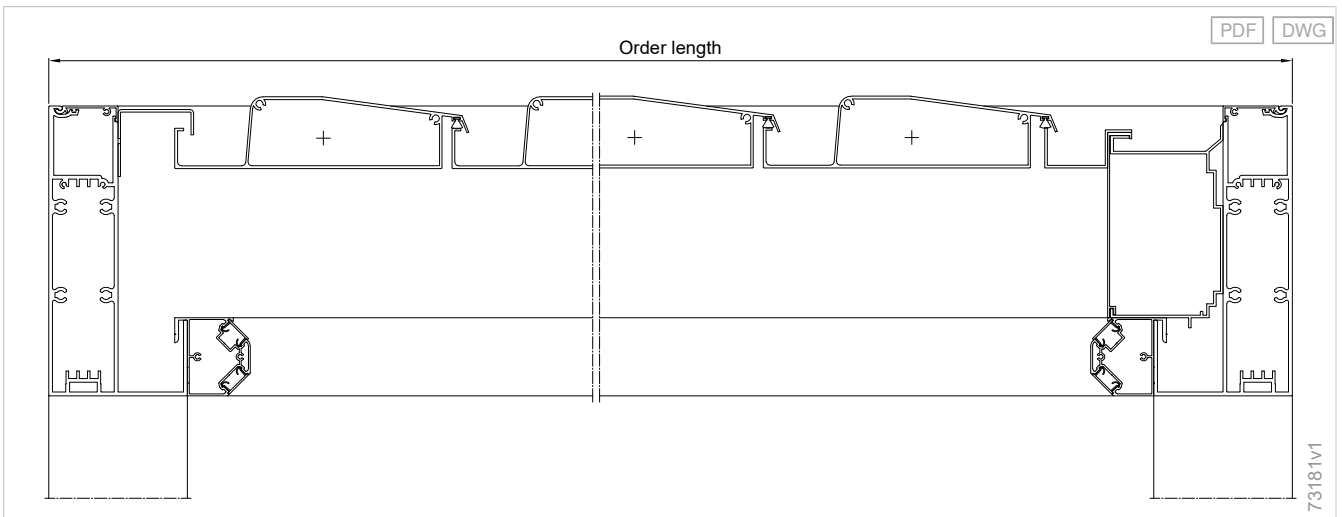

Glass roofs
Lamaxa

Fabric roofs
Lamaxa

Joint order width - L50 Line

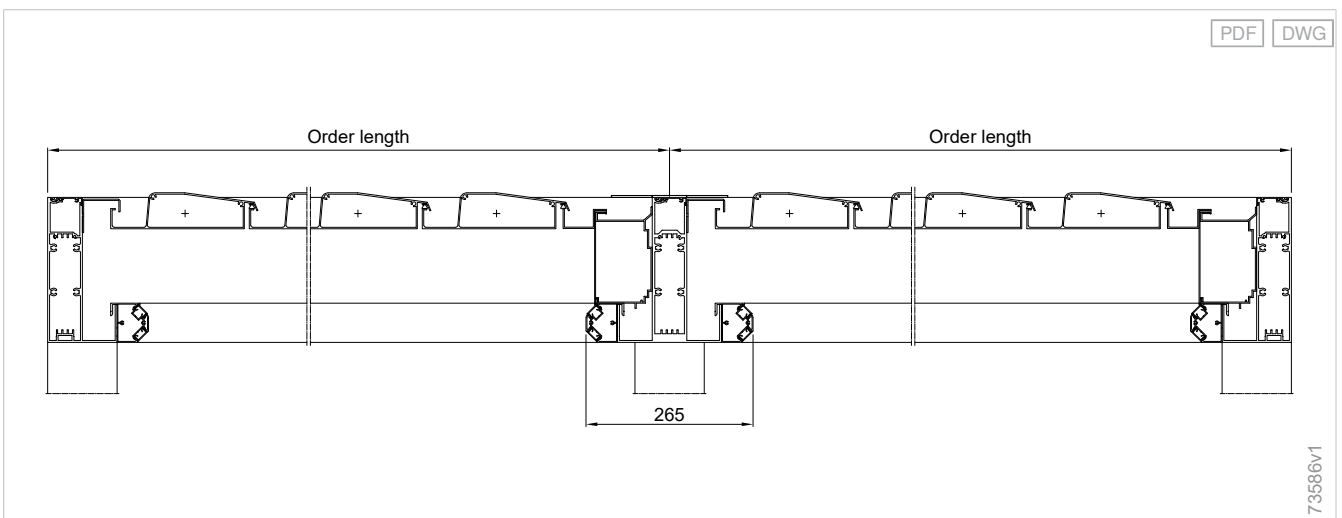

Supplementary
accessories

Drive
variants

Standards

Joint order length - L50 Line

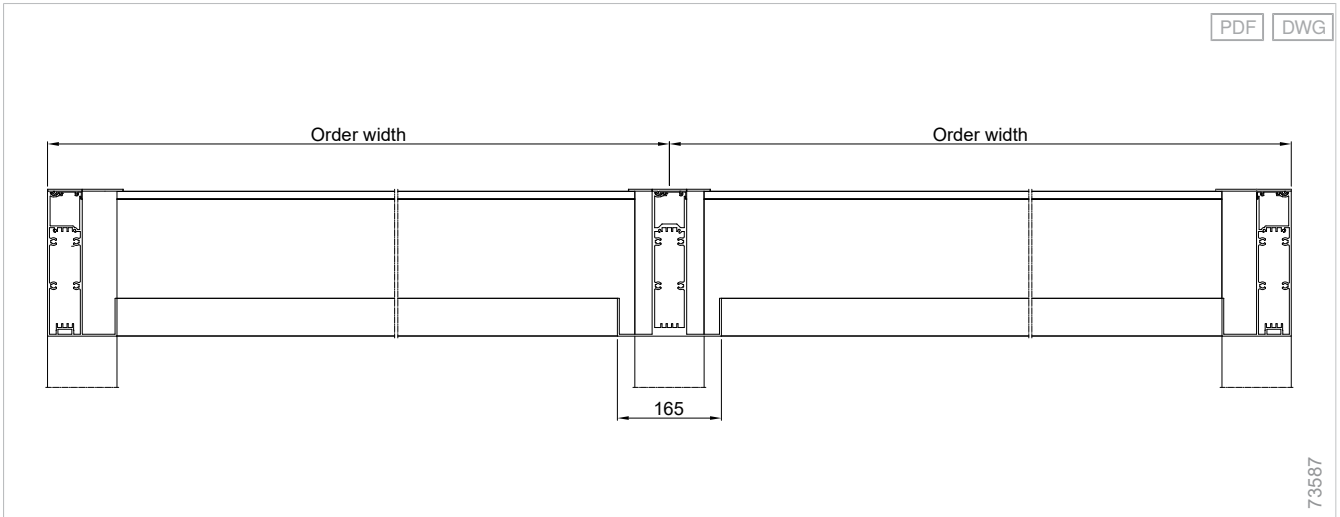

Middle crossbeam - L50 Line

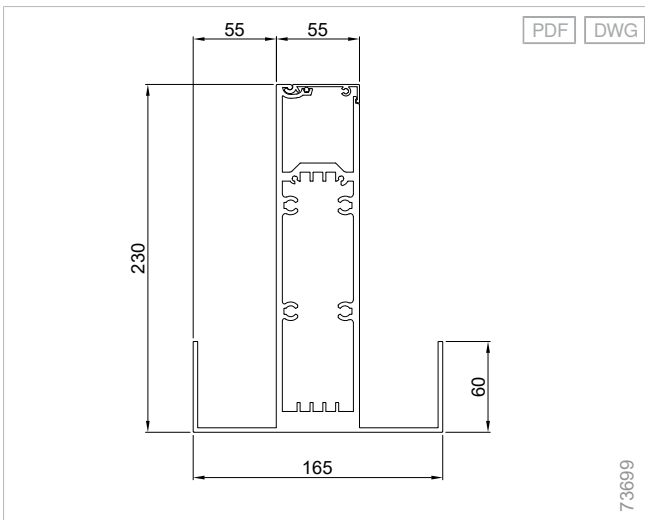

Wall console - L50 Line

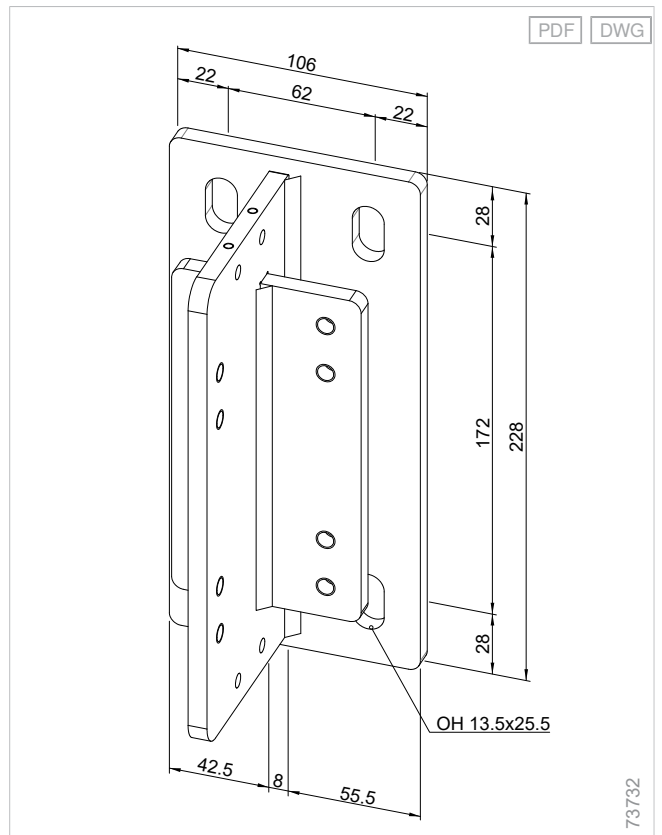

Mounting examples

Joint order width - Lamaxa Line L50/L60

PDF DWG

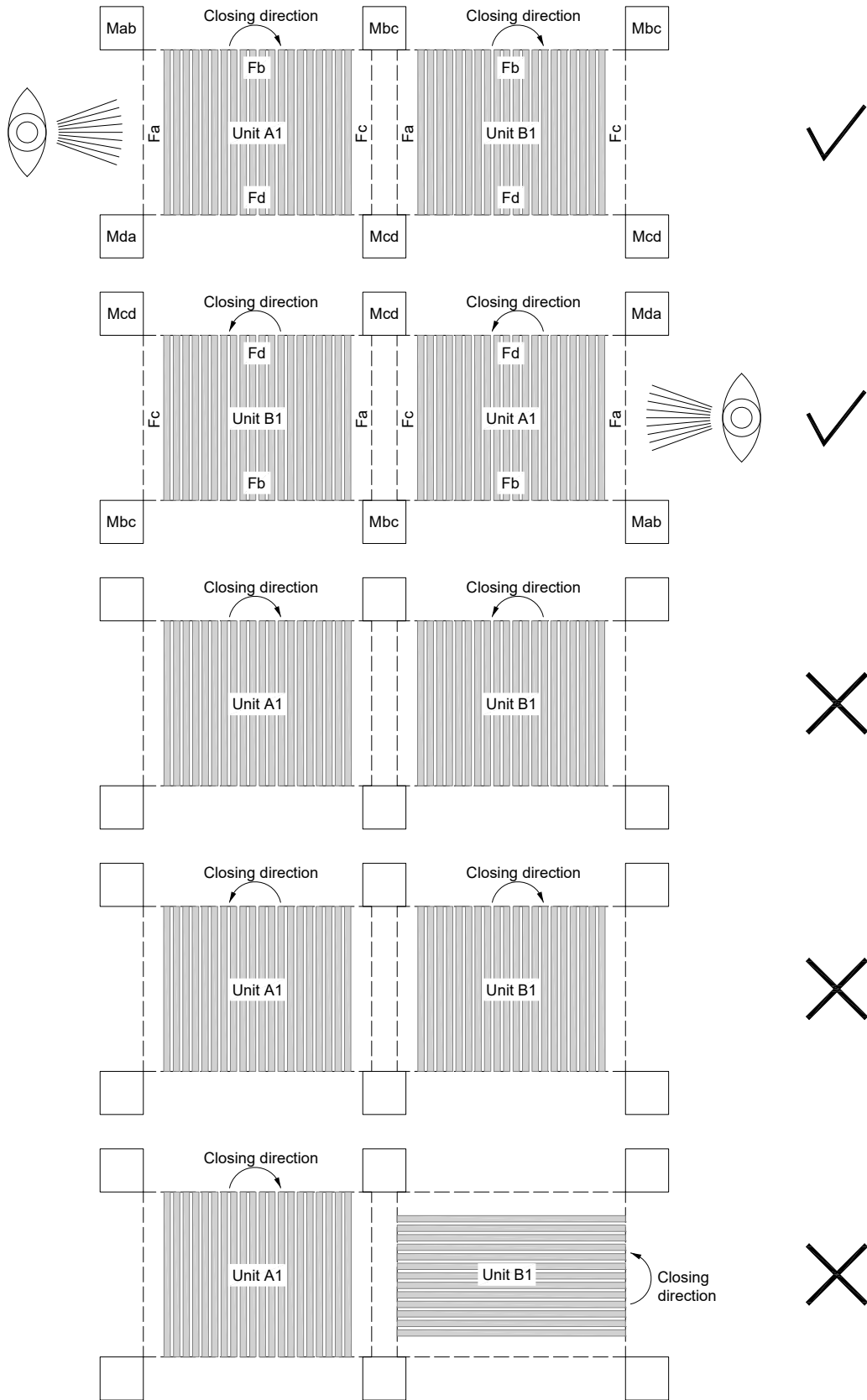

73576v1

Planning

Slat roofs Lamaxa

Glass roofs Lamaxa

Fabric roofs Lamaxa

Supplementary accessories

Drive variants

Standards

Joint order length - Lamaxa Line L50/L60

PDF DWG

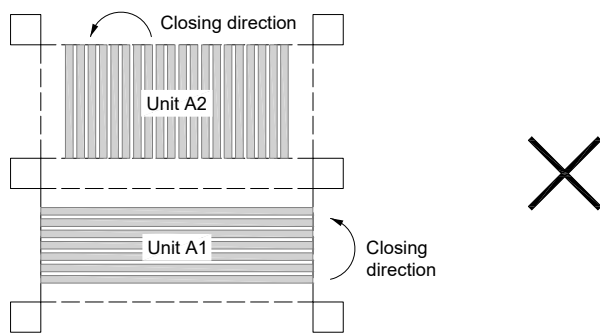
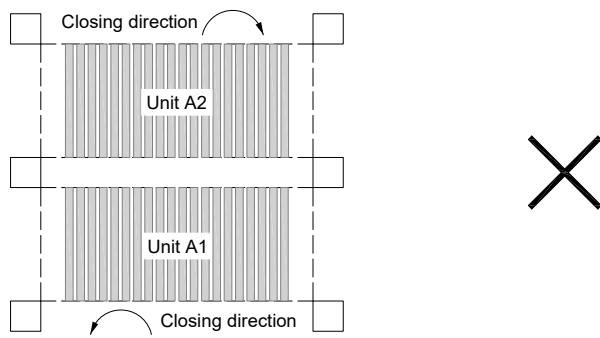
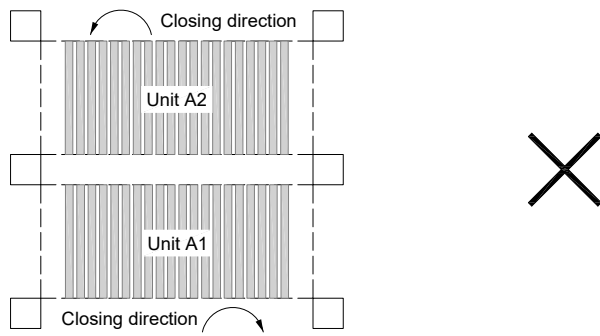
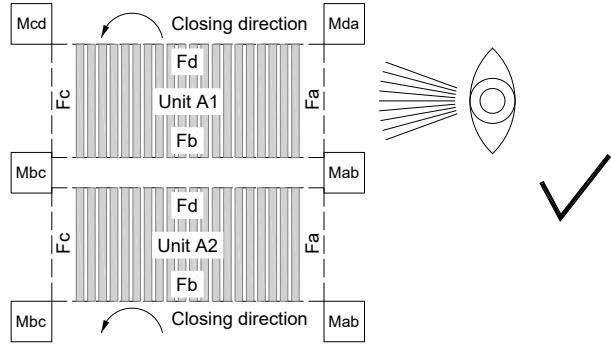
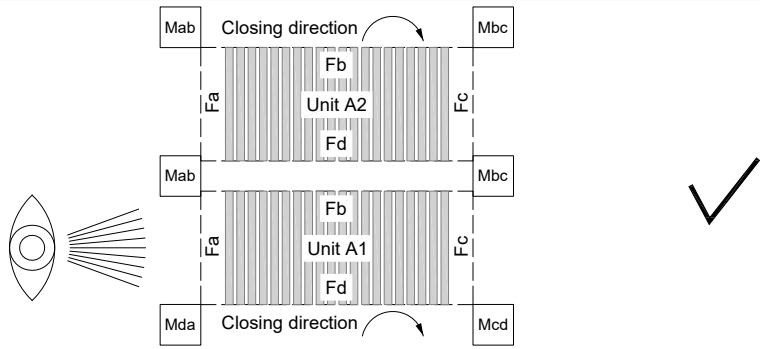

73577v1

Side view of wall connection - L50 Line/star unit

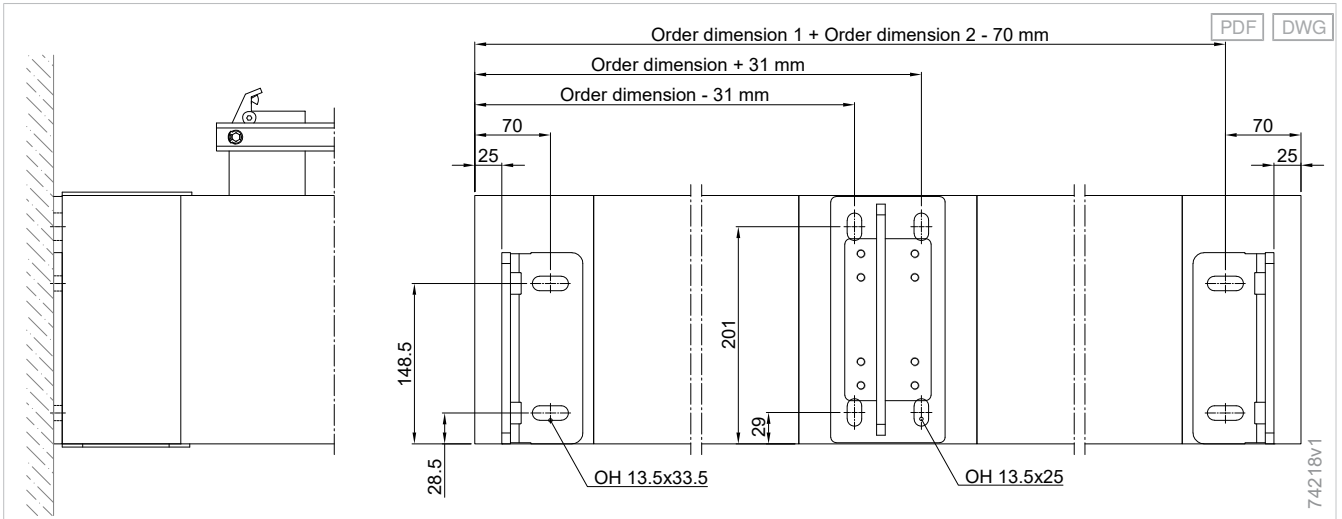

Starting point positioning example 1 - L50 Line

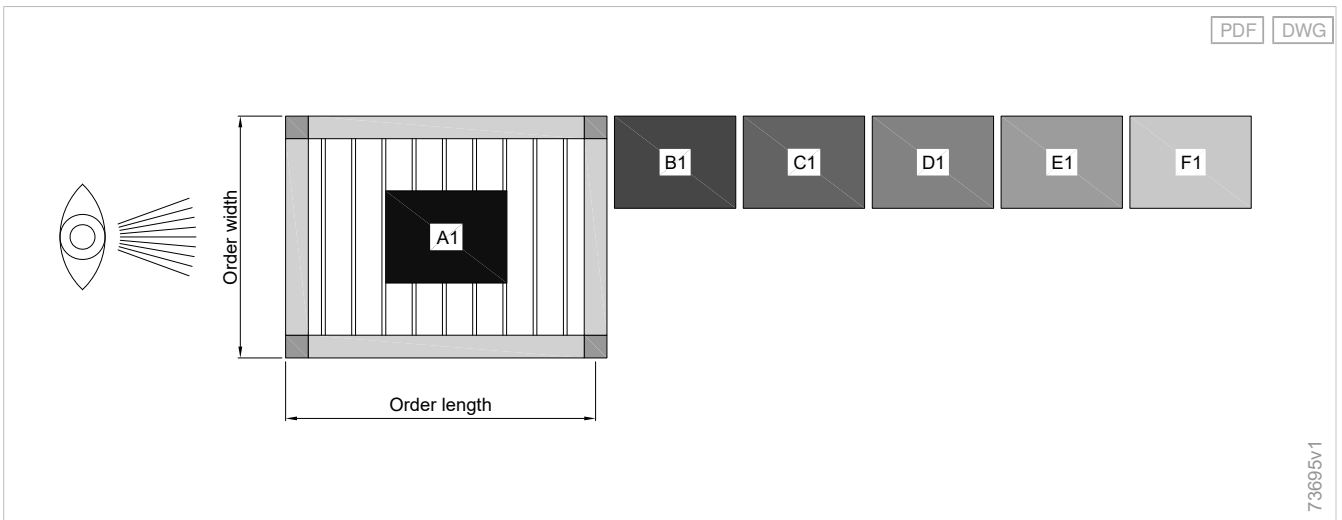

Planning

Slat roofs
Lamaxa

Glass roofs
Lamaxa

Fabric roofs
Lamaxa

Supplementary
accessories

Drive
variants

Standards

Starting point positioning example 2 - L50 Line

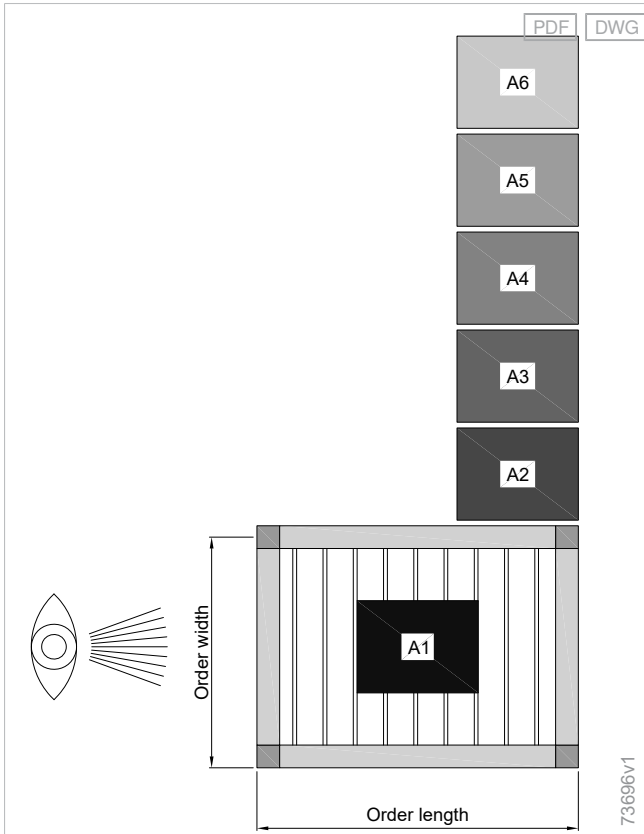

Starting point positioning example 3 - L50 star system

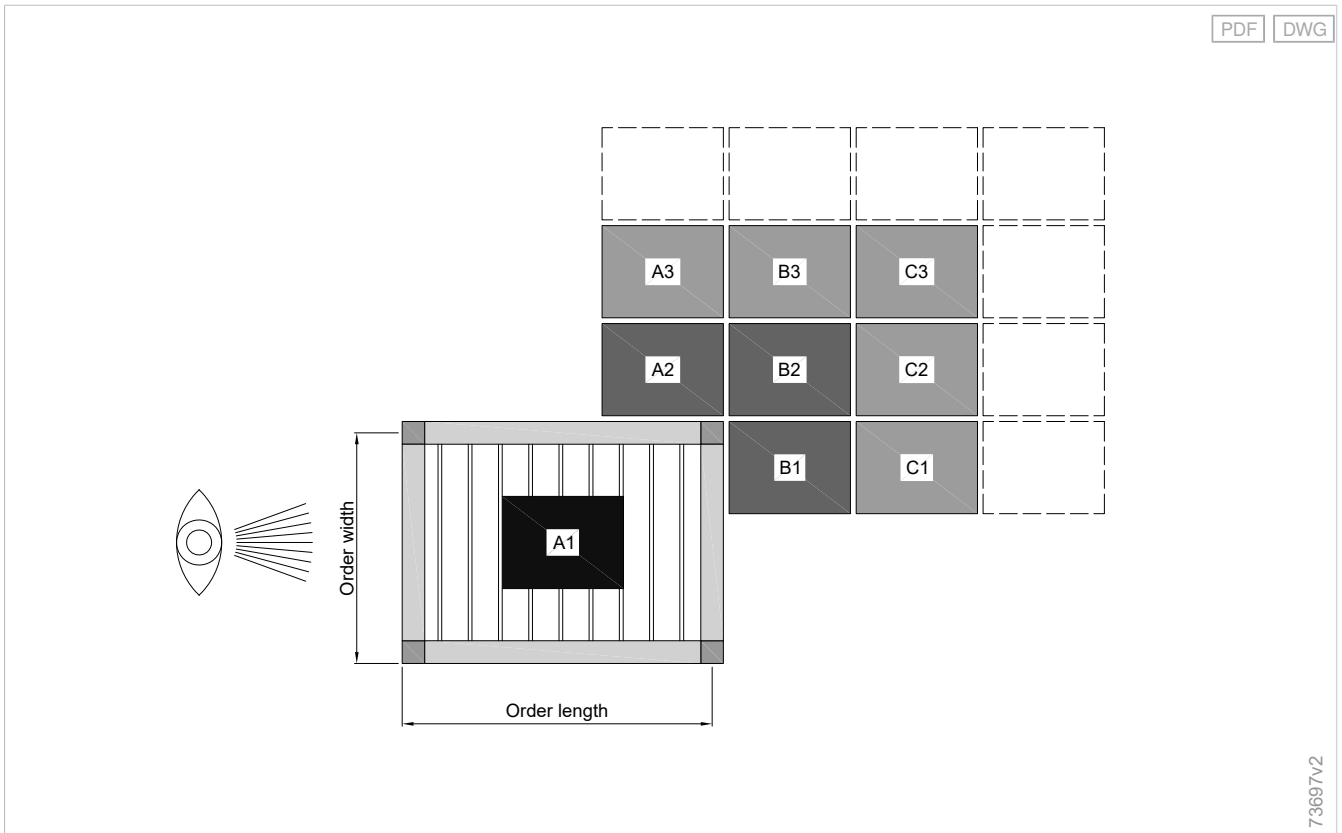

Contents

Glass roofs Lamaxa

Glass roofs Lamaxa L50 View..... 114

Planning

Slat roofs
Lamaxa

Glass roofs
Lamaxa

Fabric roofs
Lamaxa

Supplementary
accessories

Drive
variants

Standards



Glass roofs Lamaxa

Glass roofs Lamaxa L50 View

Design-focused

Year-round weather protection with style: The Cubic Line offers the most slender cubic roof on the market - complemented by perfectly coordinated brackets as well as a custom-fit awning.

Expansive

Large protected area with lots of light: The self-supporting glass roof covers areas up to 6 m in width and 4.5 m in length - with 4 poles or with 2 poles when connected to the wall.

Optional additions

Lateral protection and lighting as a practical addition: Flush integration of glass sliding systems, sliding shutters or textile GranTex with easyZIP guidance protect the glazed area from prying eyes, wind and weather. Flush-mounted LEDs in the rafter optimally illuminate the area.

Construction limit values

Maximum order width	7000 mm
Maximum order length	4500 mm
Maximum order area	31.5 m ²

Order here

myWAREMA

[Art.-Nr. 2040239](#)

WAREMA tools

[Sun Shading Planner](#)

[+ see "Navigating the document", Page 5](#)

Components

Glass roof Lamaxa L50 View

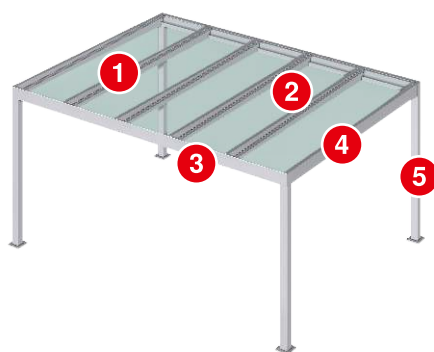

- | | | | |
|---|--------------------------------------------------------|---|-------------|
| 1 | Rafters | 4 | Edge rafter |
| 2 | Glass covering (not included in the scope of delivery) | 5 | Pole |
| 3 | Crossbeam | | |

Rafters

Rafter - L50 View

Material	Aluminium, extruded
Surface	Powder-coated
Material, notes	With glass support profile for 10 mm or 12 mm laminated safety glass.
Width	55 mm
Length	200 mm

Edge rafter - L50 View

Material	Aluminium, extruded
Surface	Powder-coated
Material, notes	With glass support profile for 10 mm or 12 mm laminated safety glass.
Width	108 mm
Height	200 mm

Pole

Pole - L50

Material	Aluminium, extruded
Surface	Powder-coated
Material, notes	one-piece
Width	110 mm
Height	110 mm

Installation options:

- Ground installation with frost-proof, on-site foundation.
- The grout for filling the clearance is not included in the scope of delivery when threaded rods are used.

Base plate

External base plate - L50 View

Material	Galvanised steel
Surface	Plain
Width	200 mm
Height	200 mm

Reinforced corner base plate - L50 View

Material	Galvanised steel
Surface	Plain
Optional surface	Powder-coated
Width	375 mm
Height	375 mm

Crossbeam

Crossbeam - L50 View

Material	Aluminium, extruded
Surface	Powder-coated
Width	110 mm
Height	200 mm

As soon as one or more electronic accessory variants (e.g. LED strips, GranTex with easyZIP guidance) are selected, the electrical distribution is performed in a plane on crossbeam a that does not convey water.

Drainage

Drainage point in pole - L50 View

- Drainage through drainpipe in pole
- In order to achieve rain class 2, at least one drainage point is required for a unit size smaller than 16 m² and at least two drainage points for a unit size ≥ 16 m². If the minimum number of drainage points is not observed, rain class 2 is not achieved.

Position of drainage outlet:

- Possible on every pole in field c
- Drainage and electronics/connecting lines must always be installed in separate poles.
- On the outsides of the poles or downward
- Height: 120 mm to 200 mm
- From 300 mm to 200 mm below the headroom

Wall connection profile, optional

Wall connection profile with small rain hood

Material	Aluminium, extruded
Surface	Powder-coated
Width	54 - 65 mm
Height	48 mm
Dimensions, notes	The adjustment range in the depth between rain hood and wall connection profile is up to 11 mm.

The on-site sealing is the responsibility of the specialist partner; if necessary, the commissioning of a plumbing company is recommended.

Field of application:

- Terrea K50
- Terrea K70
- Perea P20 (up to an angle of 10°)
- Lamaxa L50/L60/L70

Colours

- WAREMA Colour World, Individual category, fine texture surface quality
- WAREMA Colour World, Highlight category, fine texture surface quality
- WAREMA Colour World, Variation category, fine texture surface quality

Colours, optional:

- WAREMA Colour World

⊕ see "Colours and finishes", Page 10

Notes

Cleaning:

Due to the cubic shape, regular cleaning of the roof is necessary.

Operation and control:

To ensure comfortable and fast operation of accessory equipment such as a Climara W10 or W20, the slat roof, we recommend WMS WebControl pro (control via smartphone, tablet, etc.) and WMS Weather station plus in order to use the control modes (e.g. sun control). To do so, a sufficiently strong radio reception must be ensured.

Number of optional extras per field:

Only one optional extra is possible per field. Either GranTex with easyZIP guidance, LED on the poles, sliding shutters with wooden or aluminium filling or the SL20e glass sliding system.

Supplementary accessories

- Design radiant heater
- GranTex with easyZIP guidance
- Additional pole - L50
- Glass sliding system SL20e
- Sliding shutters - L50/L60/L70
- Lamaxa lighting
- Conservatory awnings Climara W10
- Conservatory awnings Climara W20

⊕ see "Supplementary accessories", Page 143

Construction limit values

Configuration variants	Snow load	Minimum order width	Maximum order width	Minimum order length	Maximum order length	Maximum order area	Minimum headroom	Maximum headroom
Lamaxa glass roofs								
Glass roofs Lamaxa L50 View	85 kg/m ²	2500 mm	7000 mm	2000 mm	4500 mm	31,5 m ²	800 mm	2700 mm
Glass roofs Lamaxa L50 View	125 kg/m ²	2500 mm	7000 mm	2000 mm	4500 mm	31,5 m ²	800 mm	2700 mm
Glass roofs Lamaxa L50 View	200 kg/m ²	2500 mm	6000 mm	2000 mm	4500 mm	27 m ²	800 mm	2700 mm
Glass roofs Lamaxa L50 View	400 kg/m ²	2500 mm	6000 mm	2000 mm	4200 mm	25,2 m ²	800 mm	2700 mm

Following enquiry, deviations from the standard construction limit values are possible (within limits), versions with snow loads of 200 kg/m² and up to 400 kg/m² are also possible on enquiry.

Snow load:

- Snow load 85 kg/m²: from an order width of 6001 mm, a third pole is required.
- Snow load 125 kg/m²: from an order width of 5501 mm, a third pole is required.
- Snow load 200 kg/m²: from an order width of 4701 mm, a third pole is required.
- Snow load 400 kg/m²: from an order width of 3701 mm, a third pole is required.

Headroom/pole height:

- The minimum height for poles with drainage is 800 mm.
- The minimum height for poles without drainage is 800 mm.
- The maximum pole height (headroom plus floor recess) is ≤ 3000 mm.

Dimension determination

Field definition - L50 View

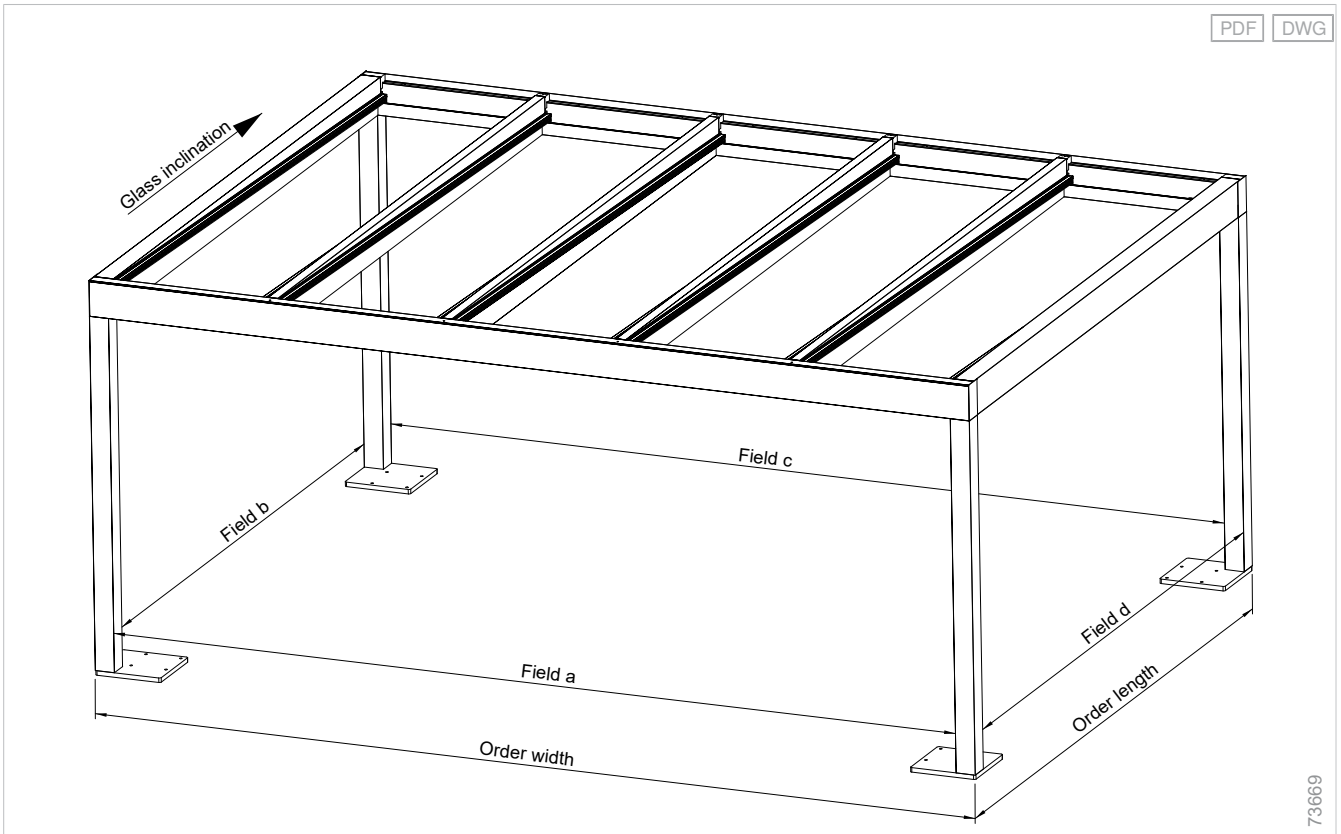

Planning

Slat roofs
Lamaxa

Glass roofs
Lamaxa

Top view of fields and poles - L50 View

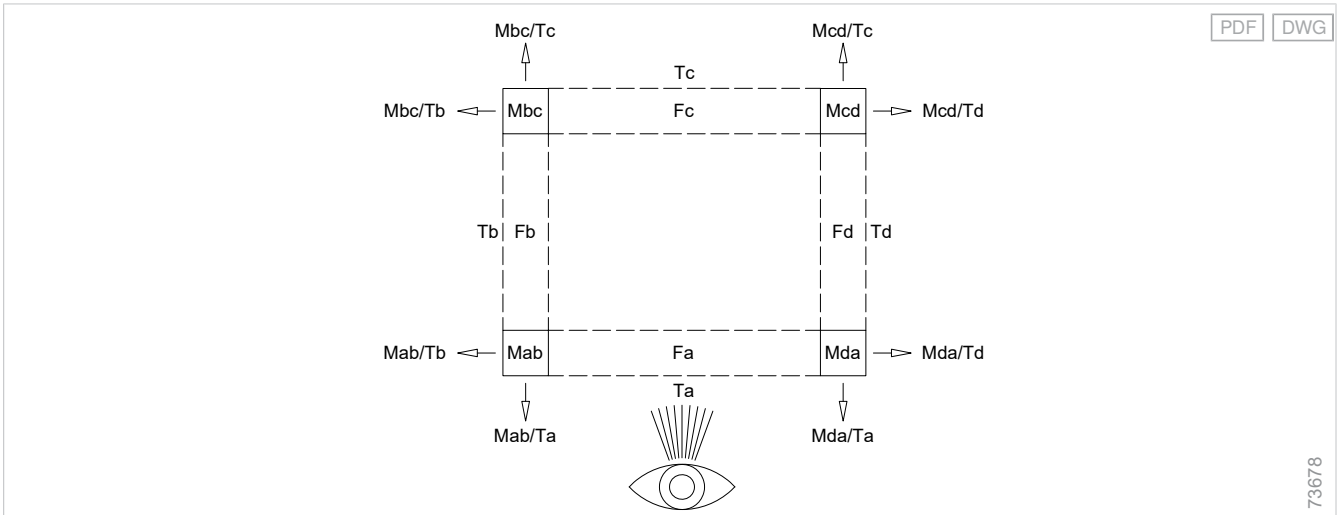

Fabric roofs
Lamaxa

Supplementary
accessories

Drive
variants

Standards

Permissible offsets for additional pole - L50 View

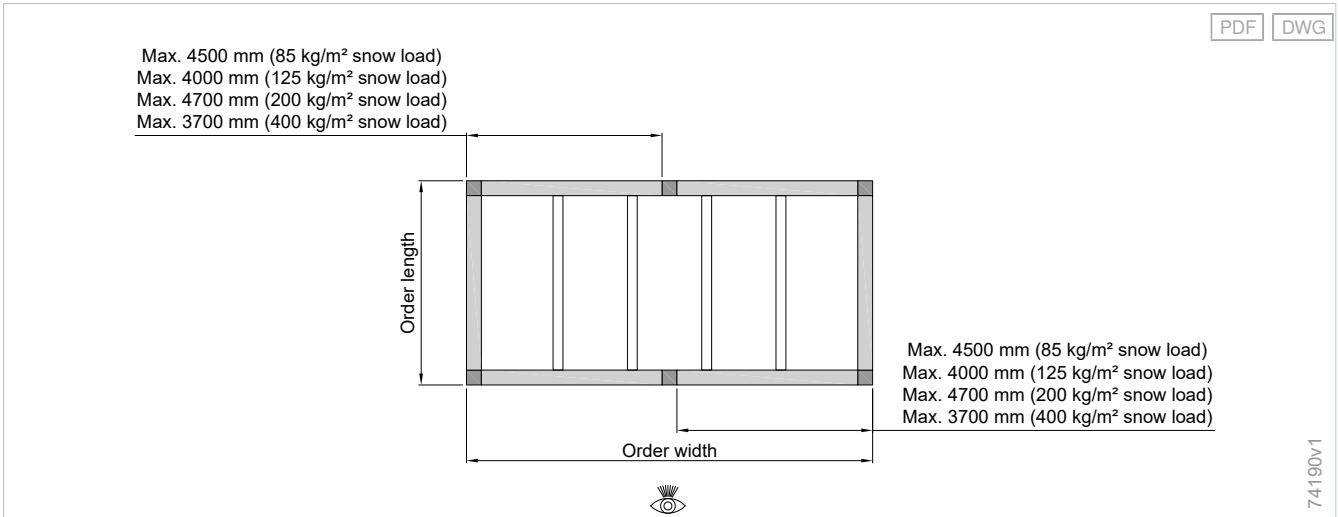

Side view - L50 View

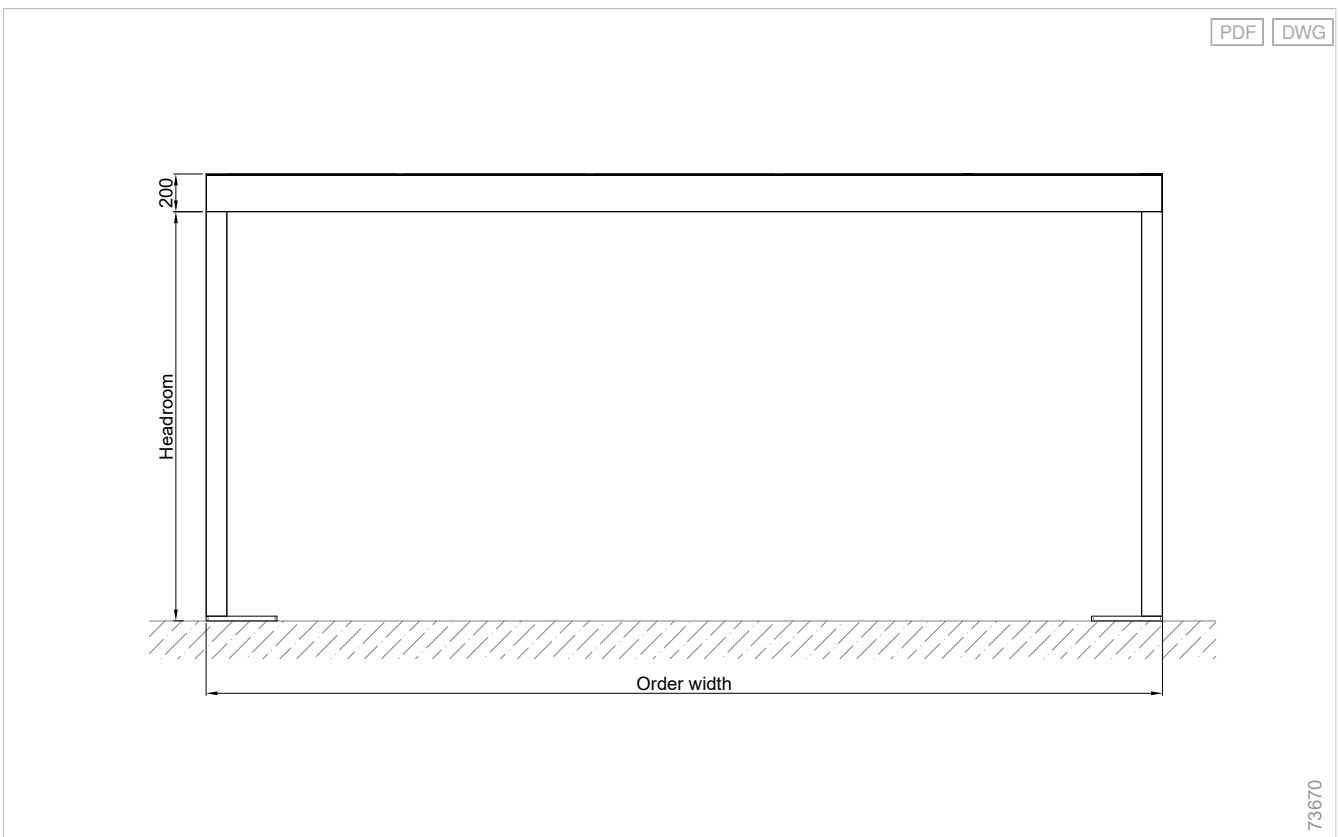

Side view of wall connection - L50 View

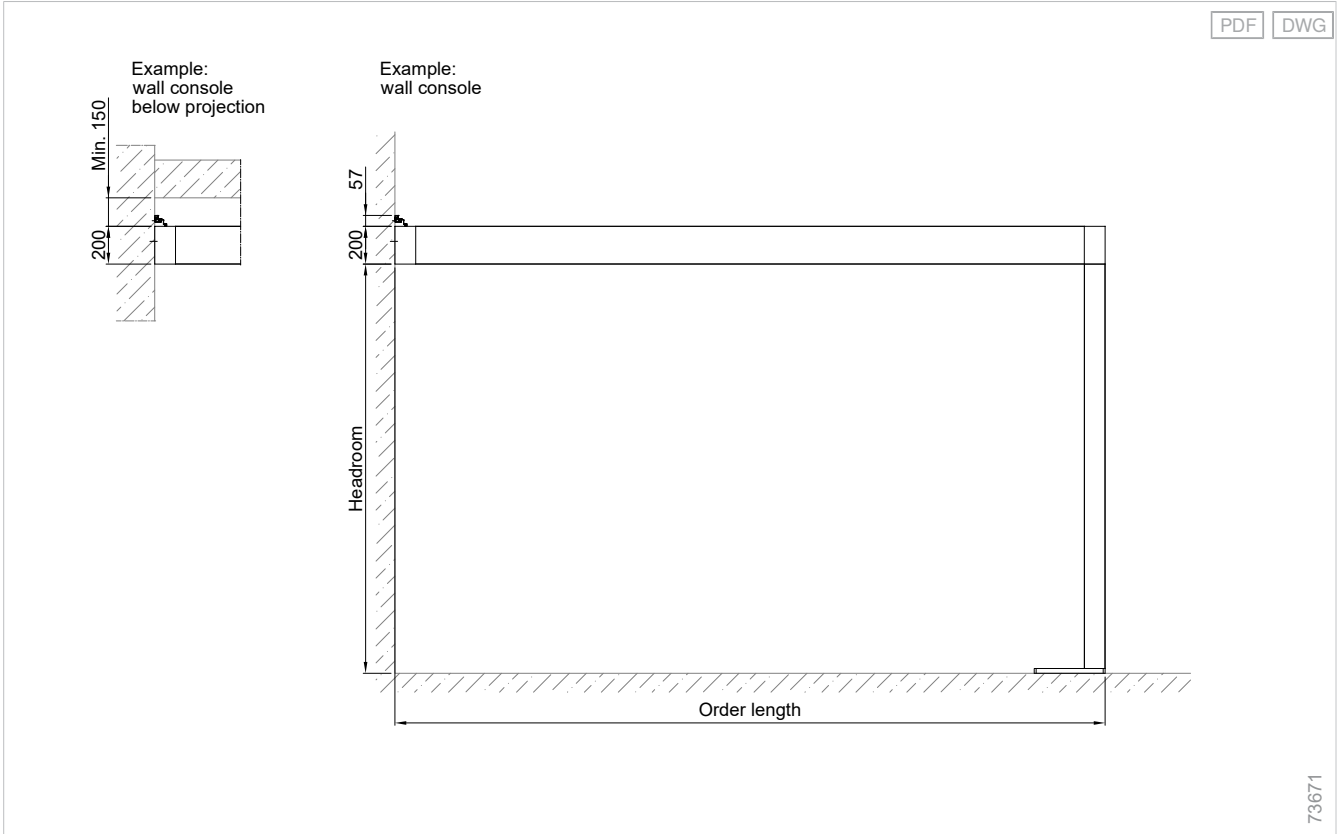

73671

Planning

Slat roofs
Lamaxa

Glass roofs
Lamaxa

Top view for individual units - L50 View

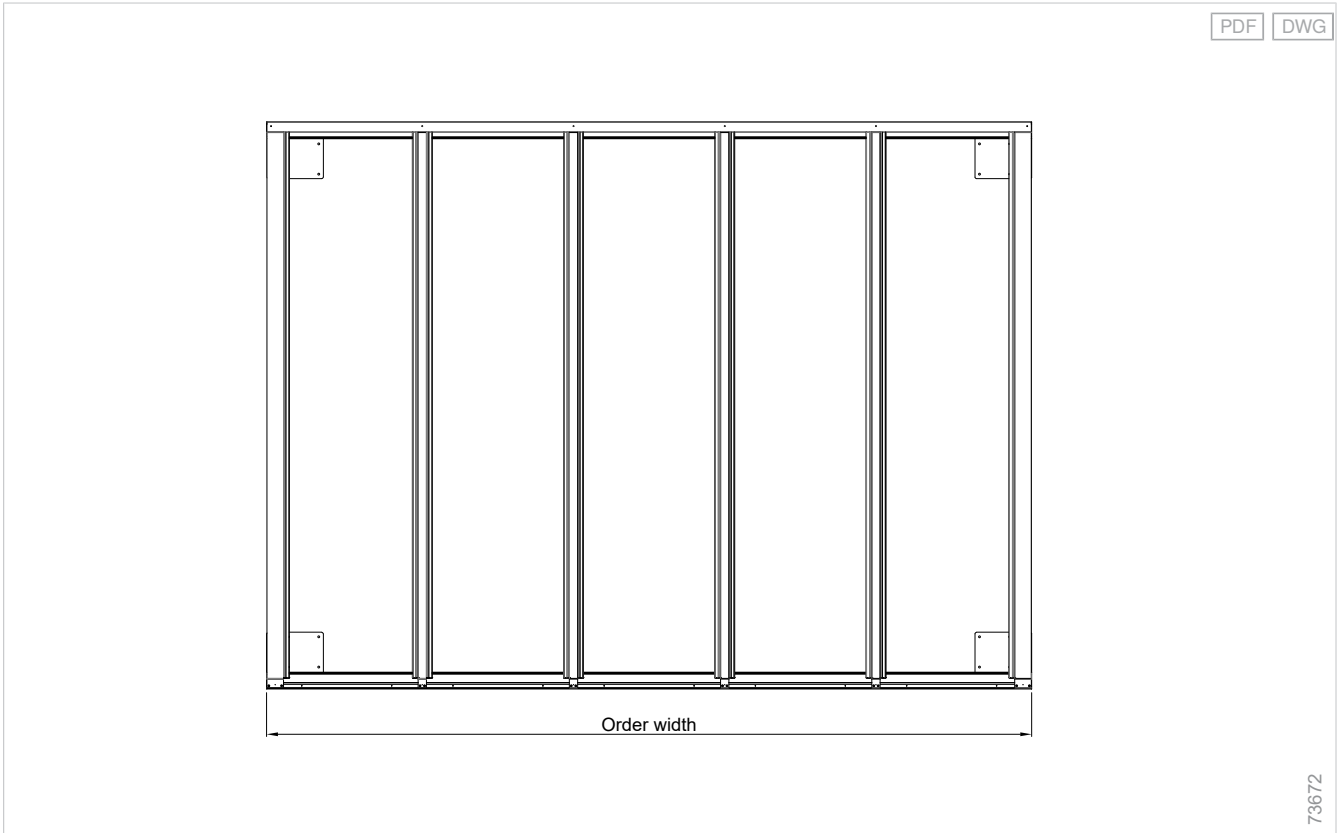

73672

Fabric roofs
Lamaxa

Supplementary
accessories

Drive
variants

Standards

Connection of conservatory awning W10 to L50 View free-standing

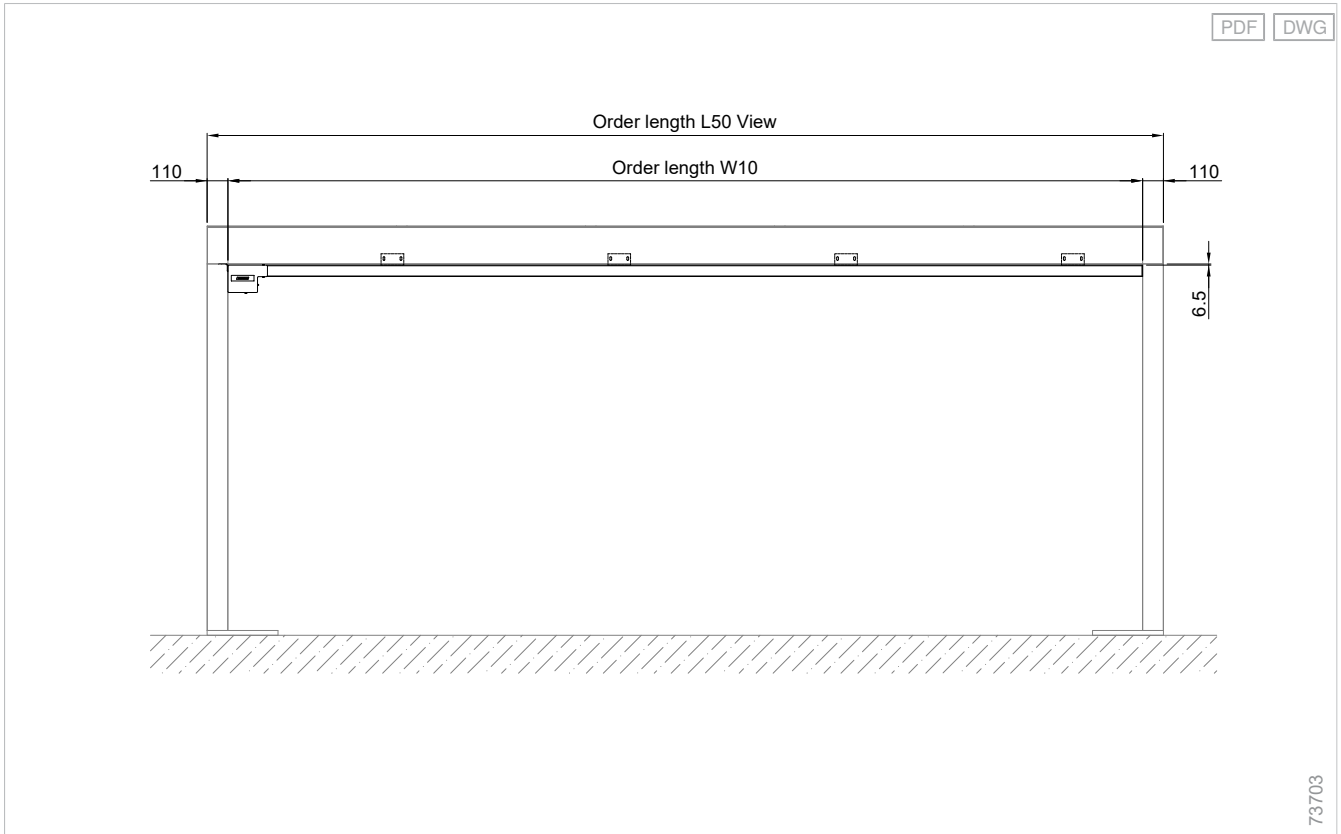

Vertical installations are possible.

Top view of conservatory awning W10 on L50 View free-standing

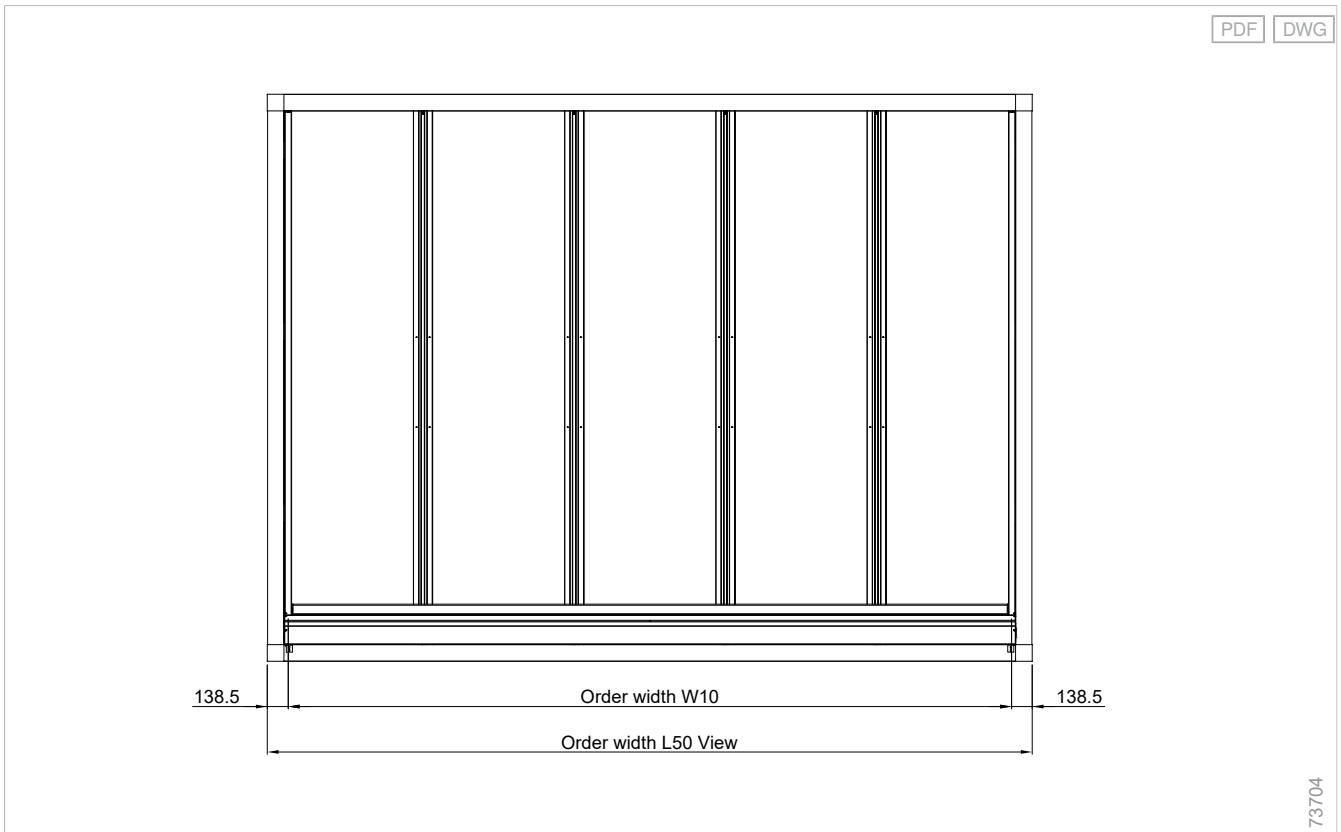

Vertical installations are possible.

Connection of conservatory awning W10 to L50 View wall connection

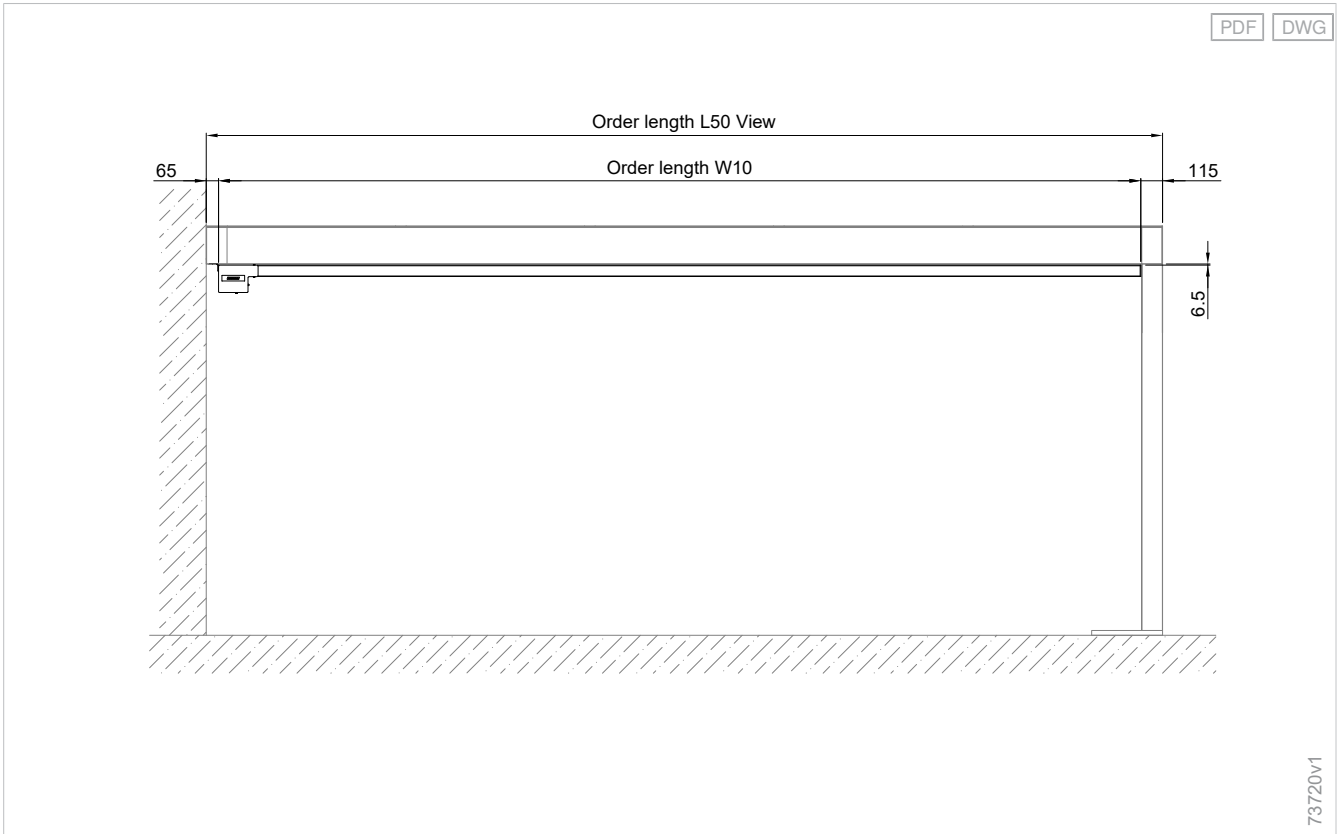

No vertical lateral installations possible.

Top view of conservatory awning W10 on L50 View wall connection

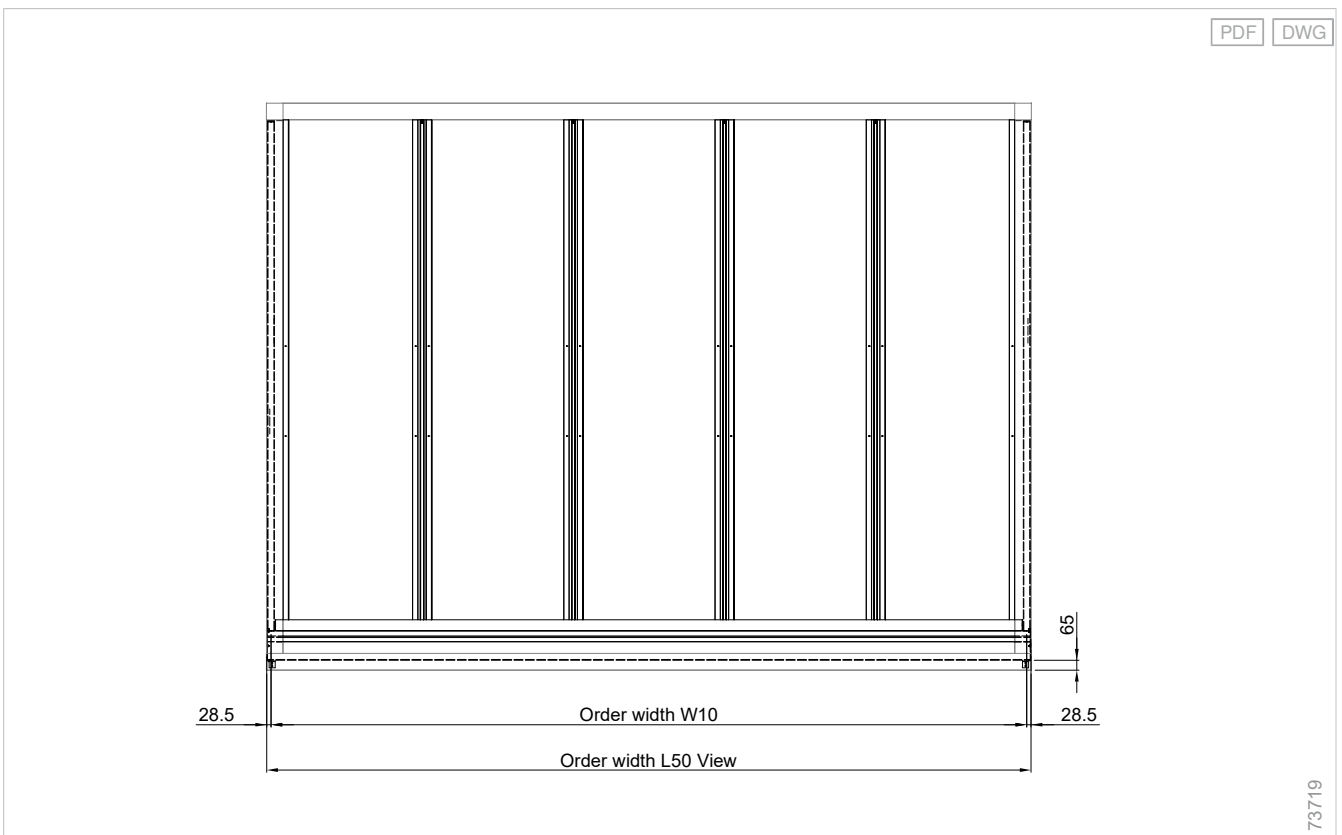

No vertical lateral installations possible.

Planning

Slat roofs
Lamaxa

Glass roofs
Lamaxa

Fabric roofs
Lamaxa

Supplementary
accessories

Drive
variants

Standards

Side view of connection of conservatory awning W10 to L50 View with wall connection

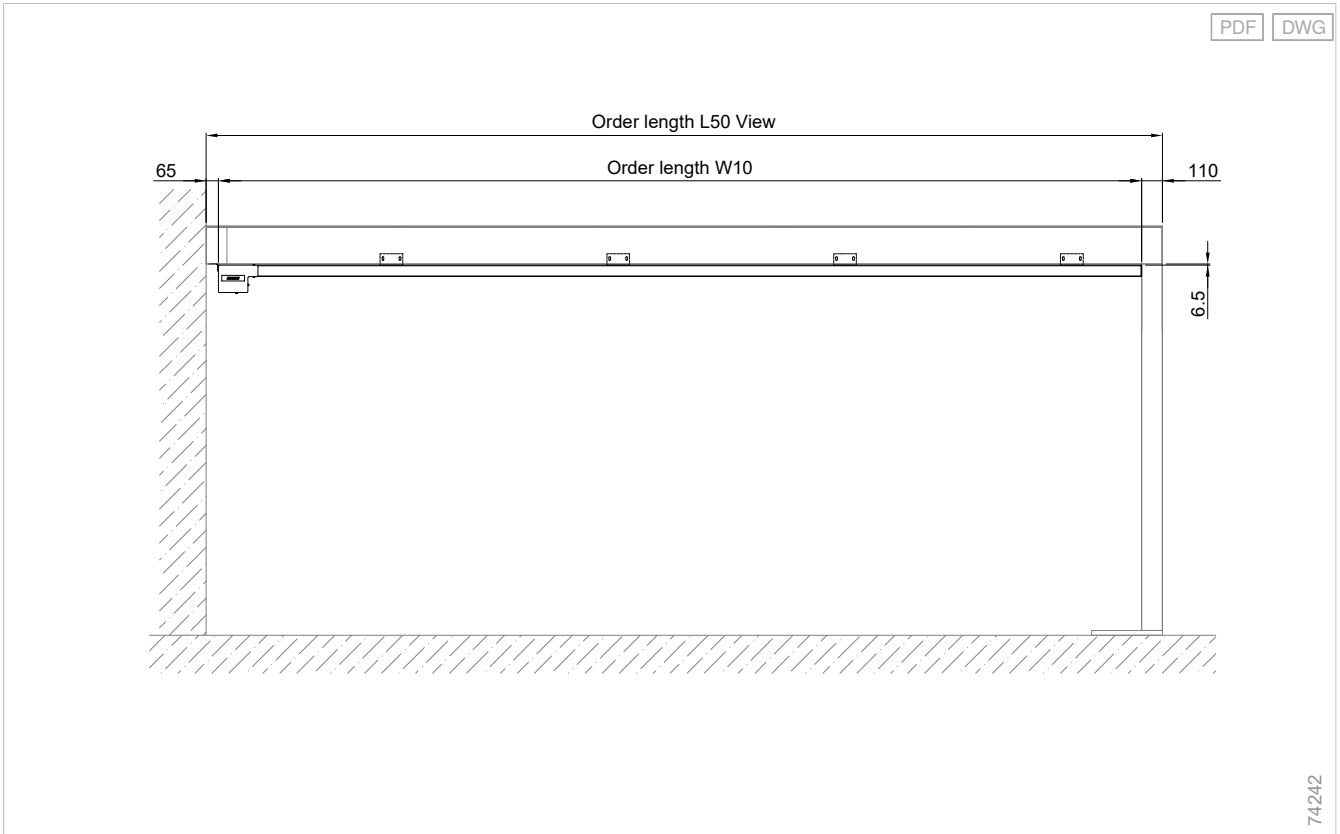

Vertical installations are possible.

Connection of conservatory awning W10 to L50 View with wall connection

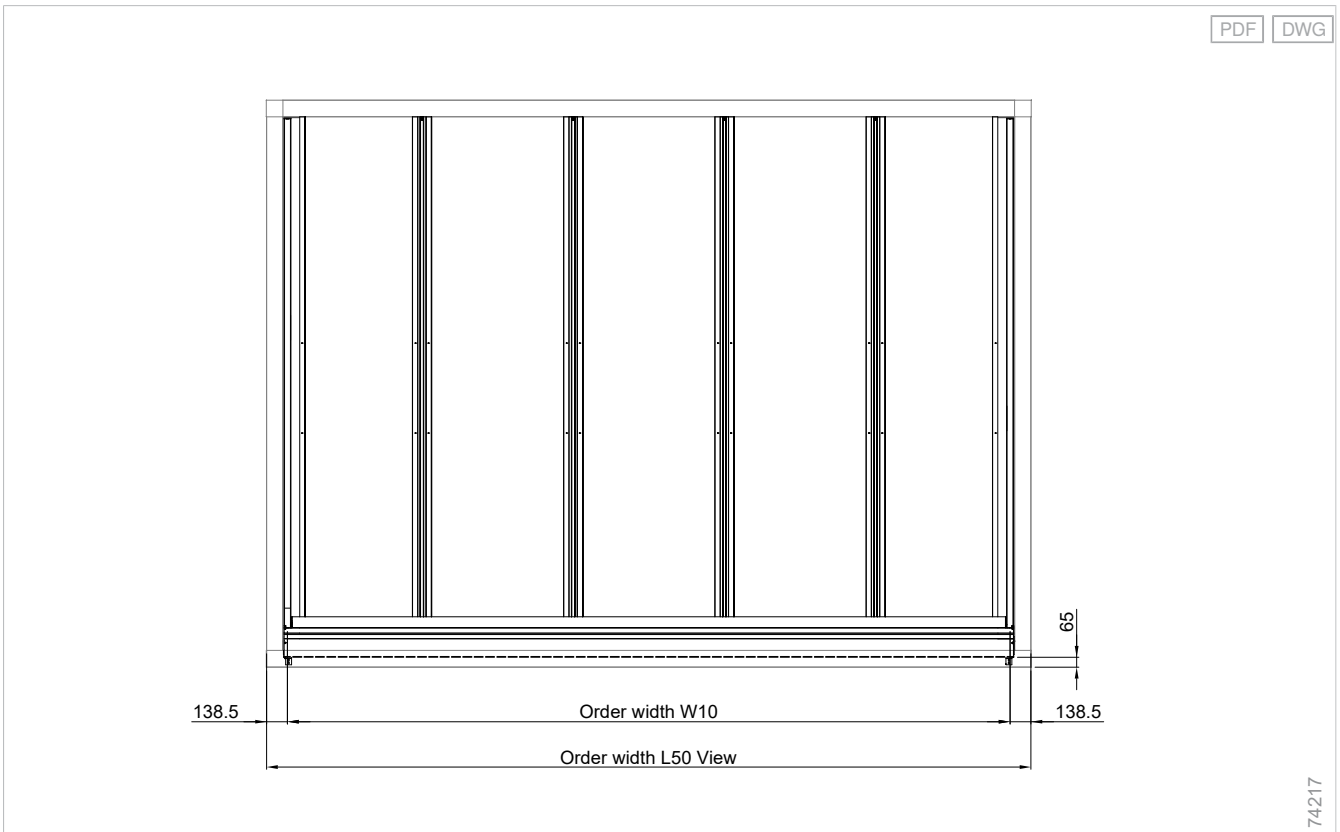

Vertical installations are possible.

Connection of conservatory awning W20 to L50 View free-standing

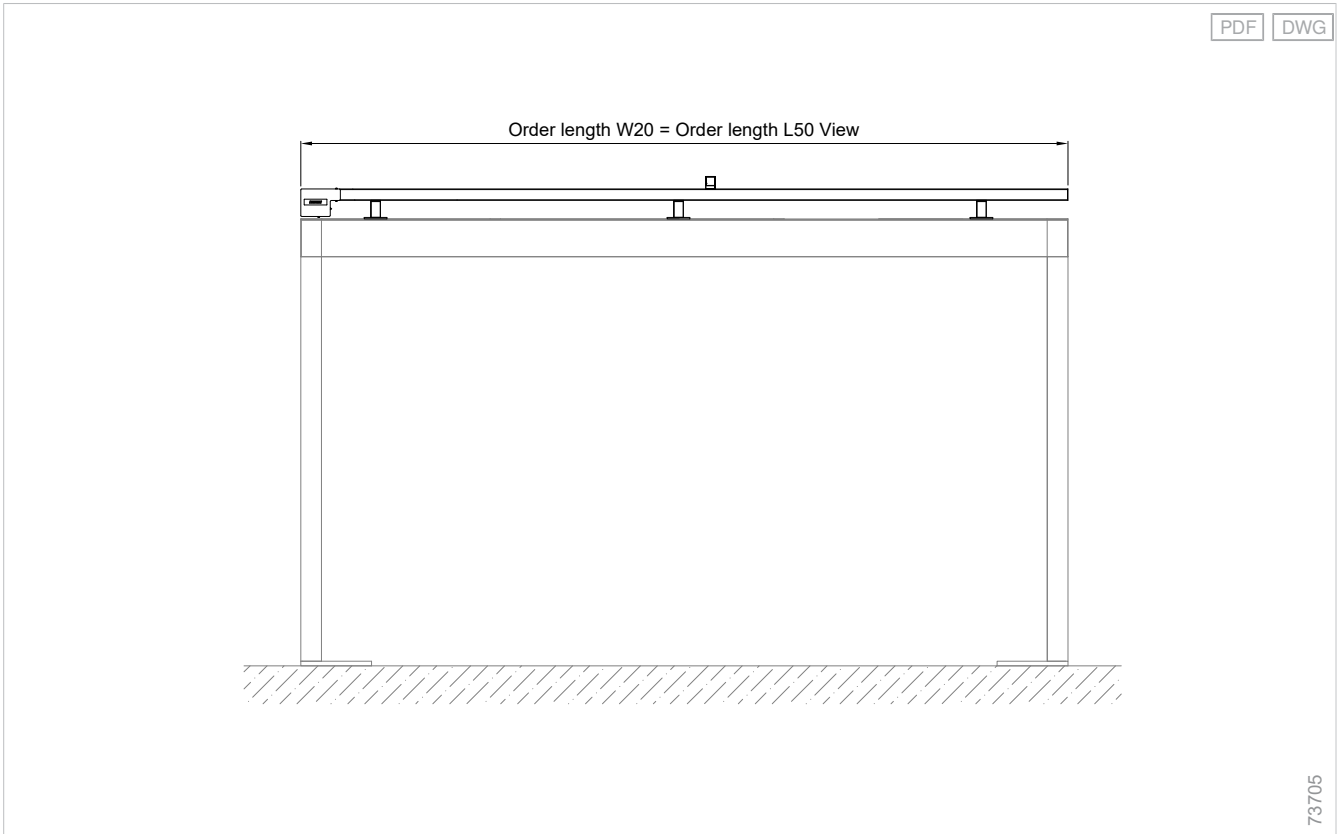

Connection of conservatory awning W20 to L50 View with wall connection analogue.

Top view of conservatory awning W20 on L50 View free-standing

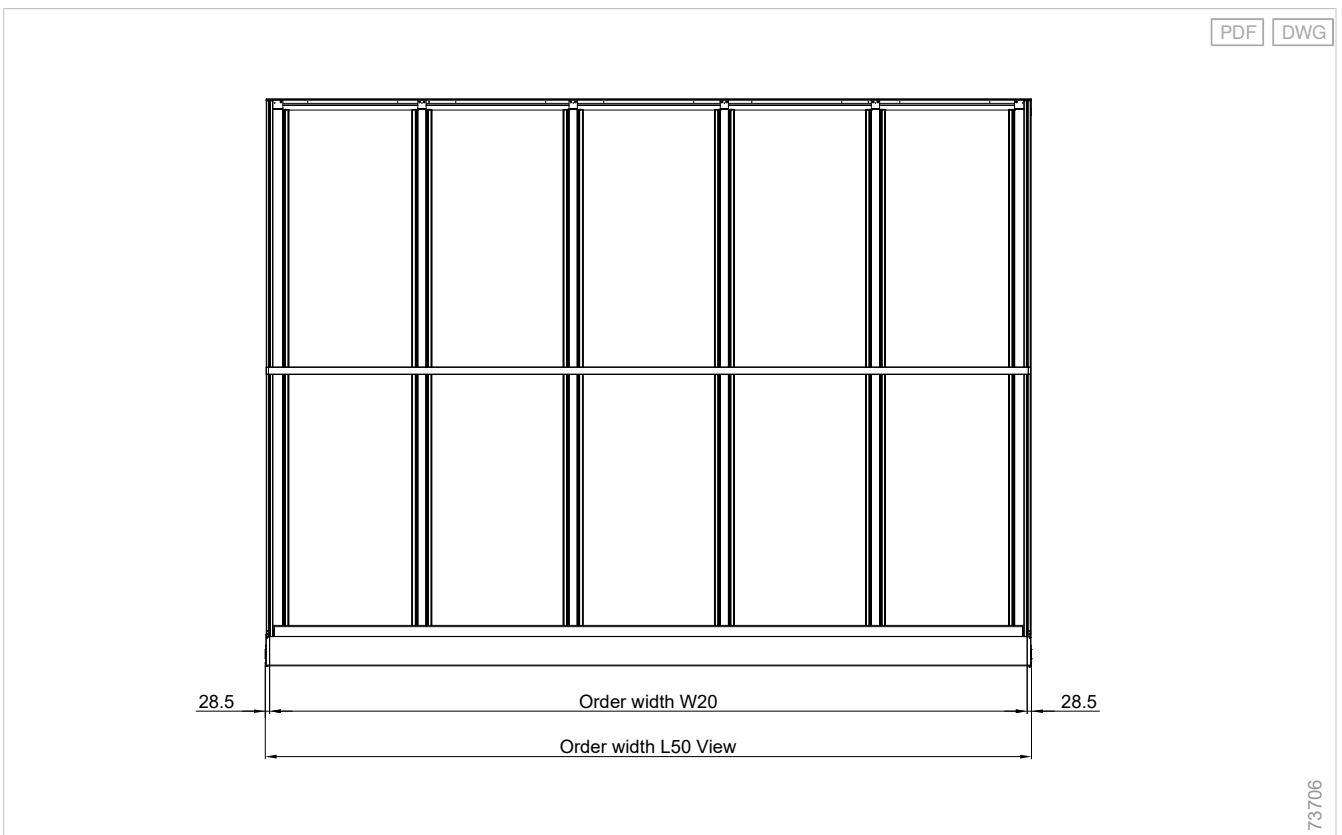

Connection of conservatory awning W20 to L50 View with wall connection analogue.

Planning

Slat roofs
Lamaxa

Glass roofs
Lamaxa

Fabric roofs
Lamaxa

Supplementary
accessories

Drive
variants

Standards

Weight assessment

Weight assessment for roof systems

Order length	Order width									
	2500 mm	3000 mm	3500 mm	4000 mm	4500 mm	5000 mm	5500 mm	6000 mm	6500 mm	7000 mm
2000 - 2500 mm	272 kg	280 kg	303 kg	311 kg	334 kg	342 kg	350 kg	373 kg	381 kg	404 kg
2501 - 3000 mm	278 kg	286 kg	310 kg	318 kg	343 kg	351 kg	359 kg	383 kg	391 kg	416 kg
3001 - 3500 mm	284 kg	292 kg	318 kg	326 kg	352 kg	360 kg	368 kg	394 kg	402 kg	428 kg
3501 - 4000 mm	290 kg	298 kg	325 kg	333 kg	361 kg	369 kg	377 kg	404 kg	412 kg	440 kg
4001 - 4500 mm	296 kg	304 kg	333 kg	341 kg	370 kg	378 kg	386 kg	415 kg	423 kg	456 kg

Please note that the weights refer to a roof without glass covering.

Details

Rafter - L50 View

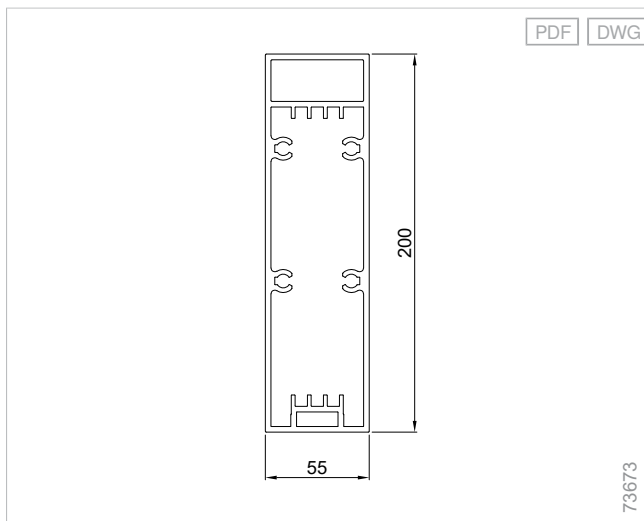

Crossbeam with drainage - L50 View

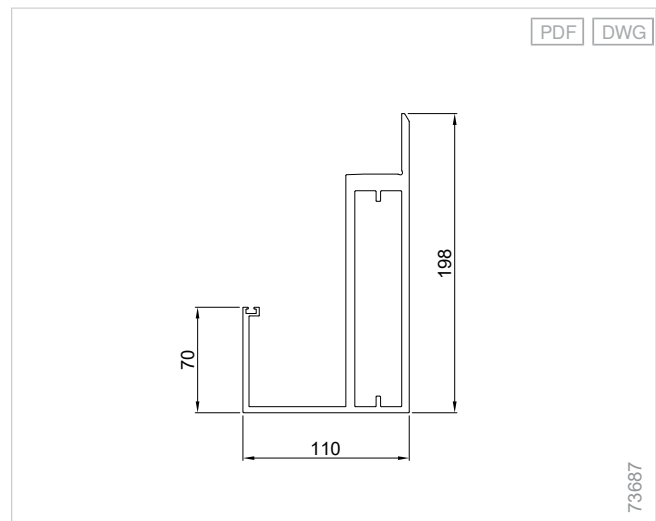

Crossbeam - L50 View

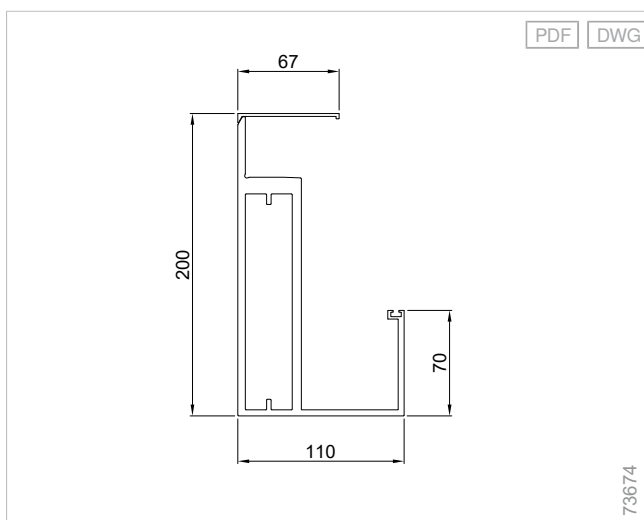

Edge rafter - L50 View

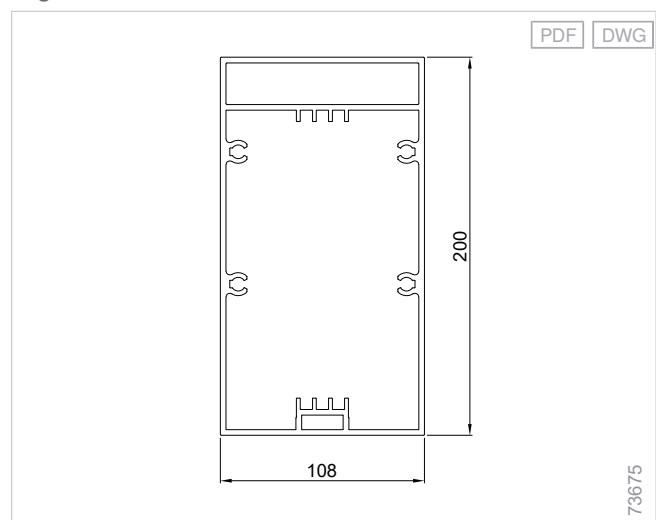

Pole - L50

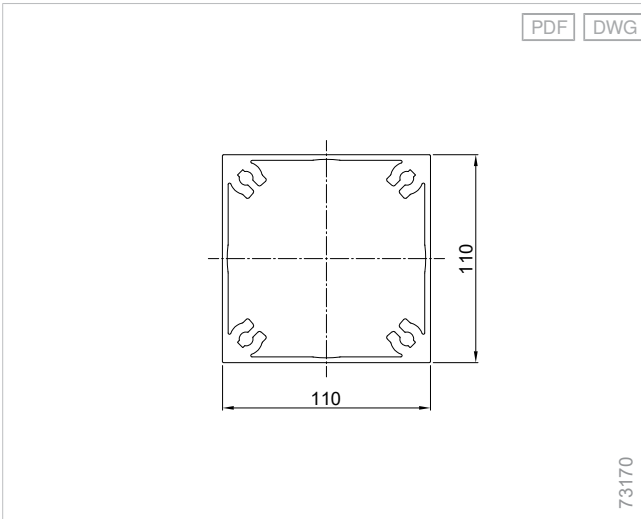

Side view with visible glass course along the rafter - L50 View

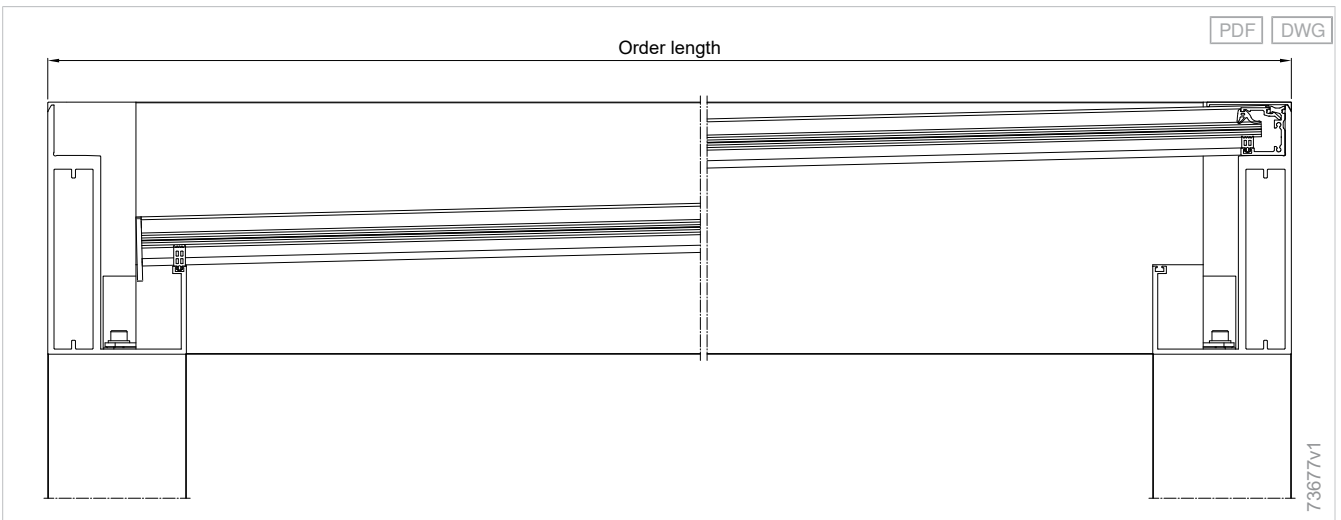

Front view of the profile cross sections - L50 View

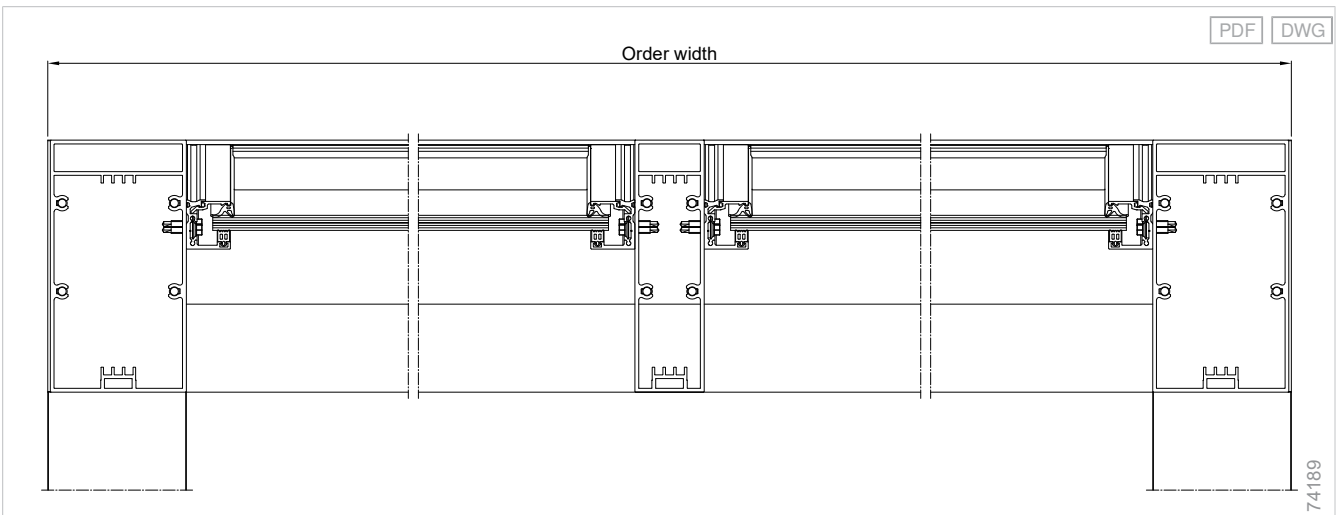

Planning

Slat roofs
Lamaxa

Glass roofs
Lamaxa

Fabric roofs
Lamaxa

Supplementary
accessories

Drive
variants

Standards

L50, position of drainage, on-site

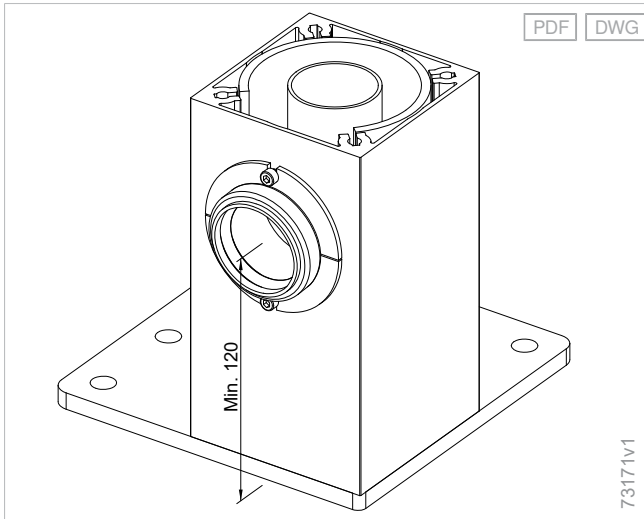

External base plate with L50 View drainage

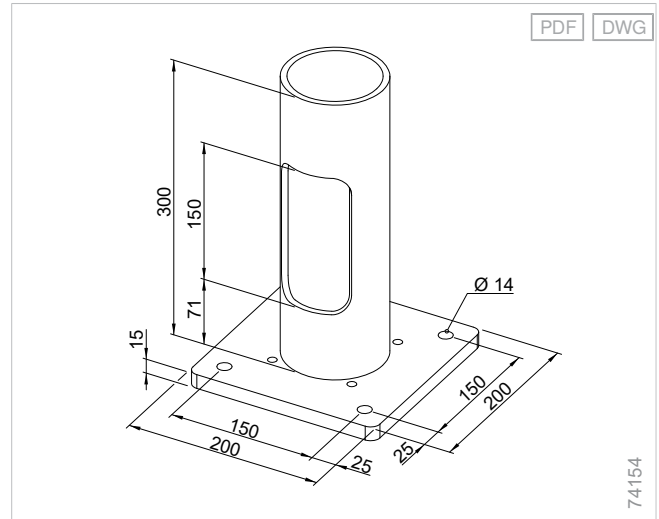

L50, rectangular drainage

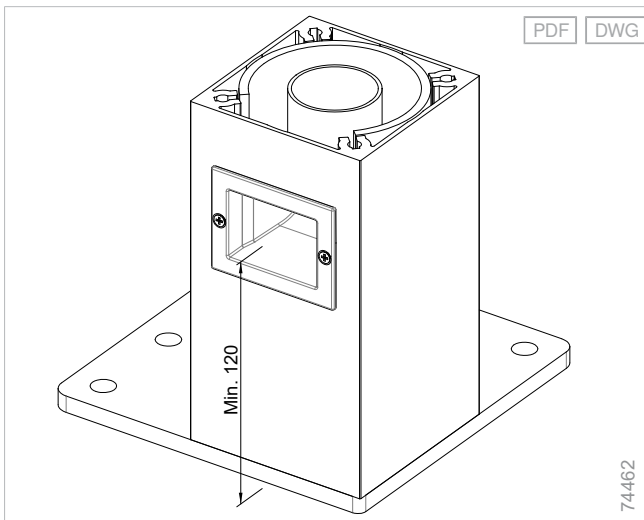

The cover for the external base plate with drainage is available on request.

Reinforced corner base plate - L50 View

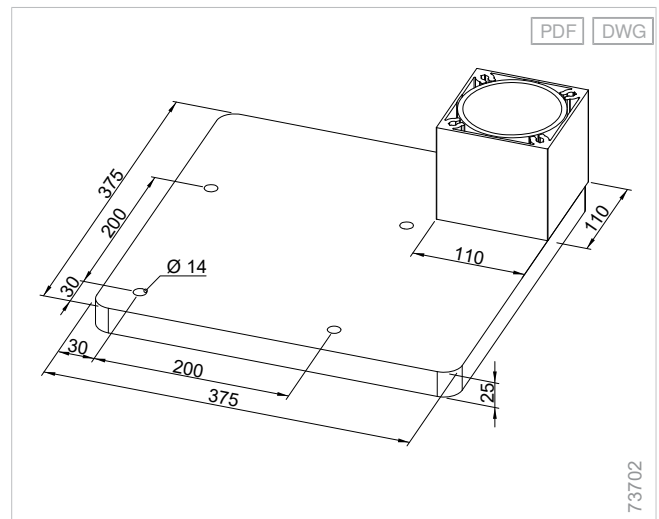

L50, rectangular drainage, optional waterspout

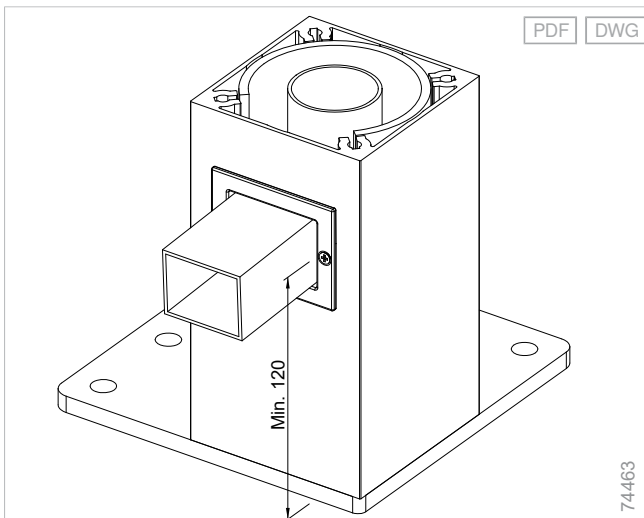

The cover for the reinforced corner base plate is available on request.

Wall connection profile with small rain hood - L50/L60/L70

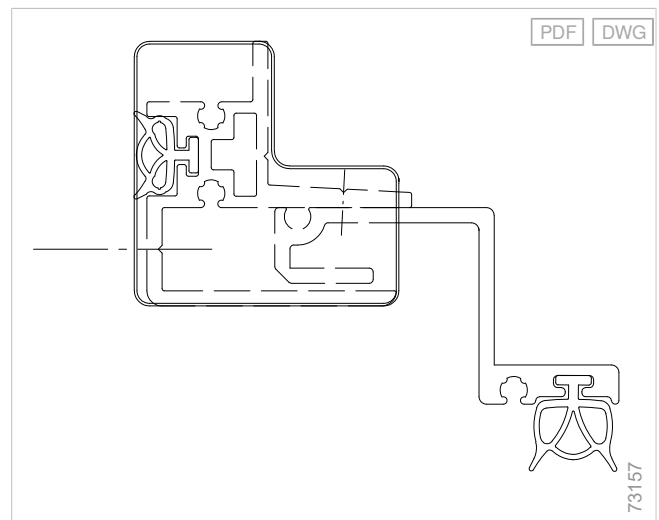

Fixing on concrete foundation (corner installation)

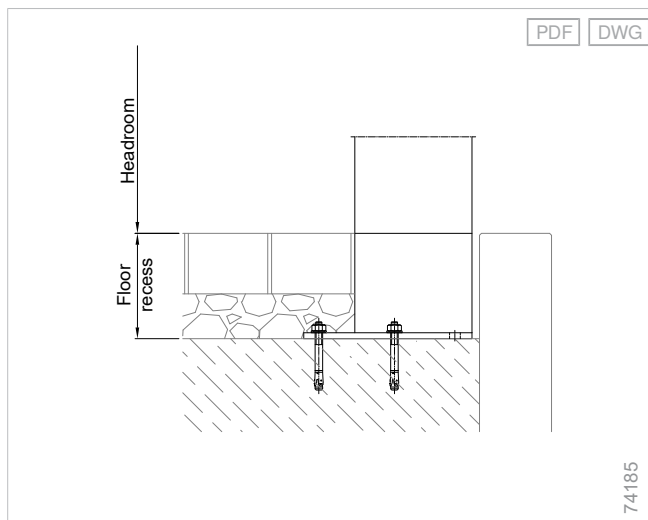

Additional product information

Optimum order width in mm (for maximum field size)

Snow load	Laminated safety glass	2 fields	3 fields	4 fields	5 fields	6 fields	7 fields
85	10	2071	3024	3977	4930	5883	6836
85	12	2401	3519	4637	5755	6873	-
125	12	2291	3354	4417	5480	6543	-
200	12	2111	3084	4057	5030	6000	-
400	12	1831	2664	3497	4330	5163	5996

- Laminated safety glass 10 mm from 2 x 5 mm TVG PVB plastic film 0.76 mm
- Laminated safety glass 12 mm from 2 x 6 mm TVG PVB plastic film 0.76 mm

Snow load: 85 kg/m²

Snow load: 85 kg/m²

Width	1000 - 4500 mm	4501 - 5000 mm	5001 - 6000 mm	6001 - 7000 mm
Depth 1000 - 4500 mm	2 x poles or 3 x poles	1 x steel or 3 x poles	2 x steel or 3 x poles	3 x poles

Snow load: 125 kg/m²

Snow load: 125 kg/m²

Width	1000 - 4000 mm	4001 - 4500 mm	4501 - 5500 mm	5501 - 7000 mm
Depth 1000 - 4500 mm	2 x poles or 3 x poles	1 x steel or 3 x poles	2 x steel or 3 x poles	3 x poles

Snow load: 200 kg/m²

Snow load: 200 kg/m²

Width	1000 - 4700 mm	4701 - 6000 mm
Depth 1000 - 4500 mm	2 x steel	2 x steel and 3 x poles

Snow load: 400 kg/m²

Snow load: 400 kg/m²

Width	1000 - 3700 mm	3701 - 6000 mm
Depth 1000 - 4200 mm	2 x steel	2 x steel and 3 x poles

Mounting examples

Application reinforced corner base plate corner mounting - L50 View

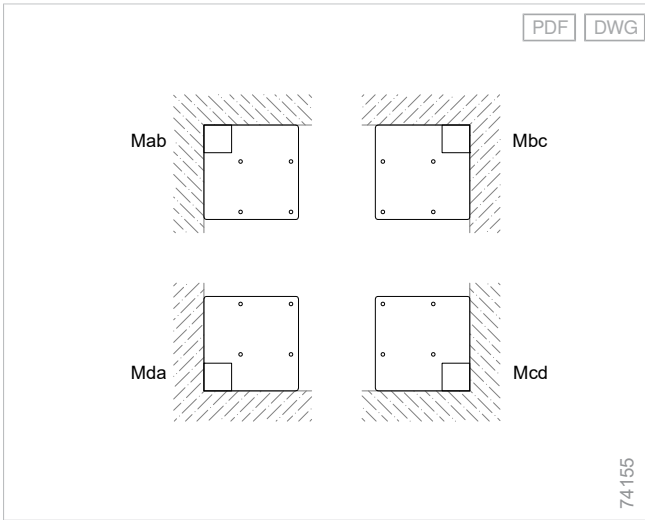

Fixing on concrete foundation (no clearance)

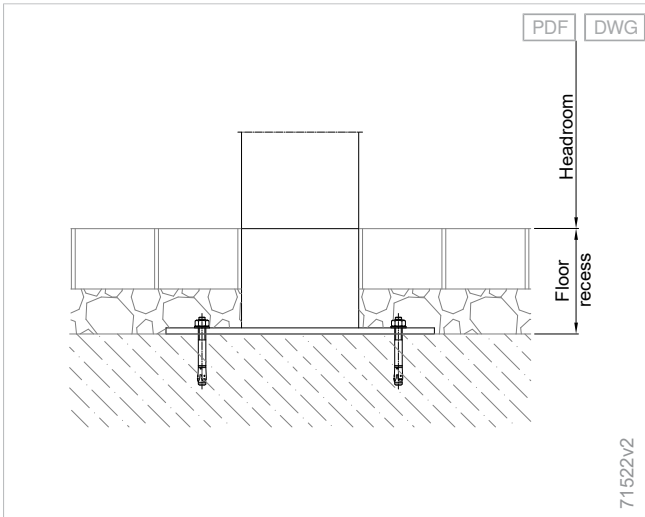

Fixing on concrete foundation (with clearance)

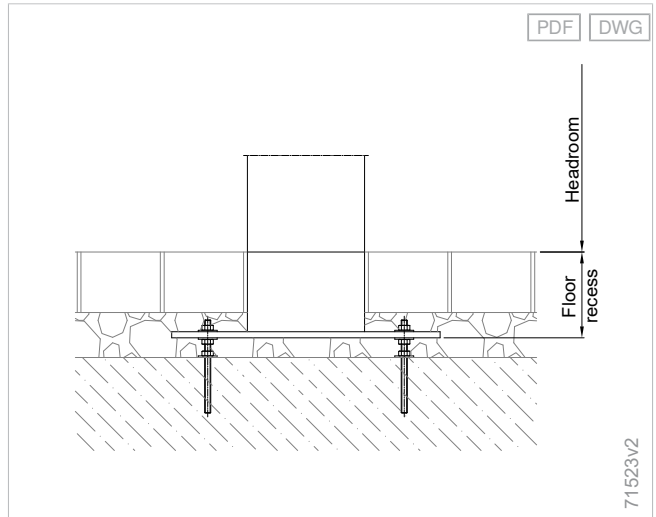

Wall connection - L50 View

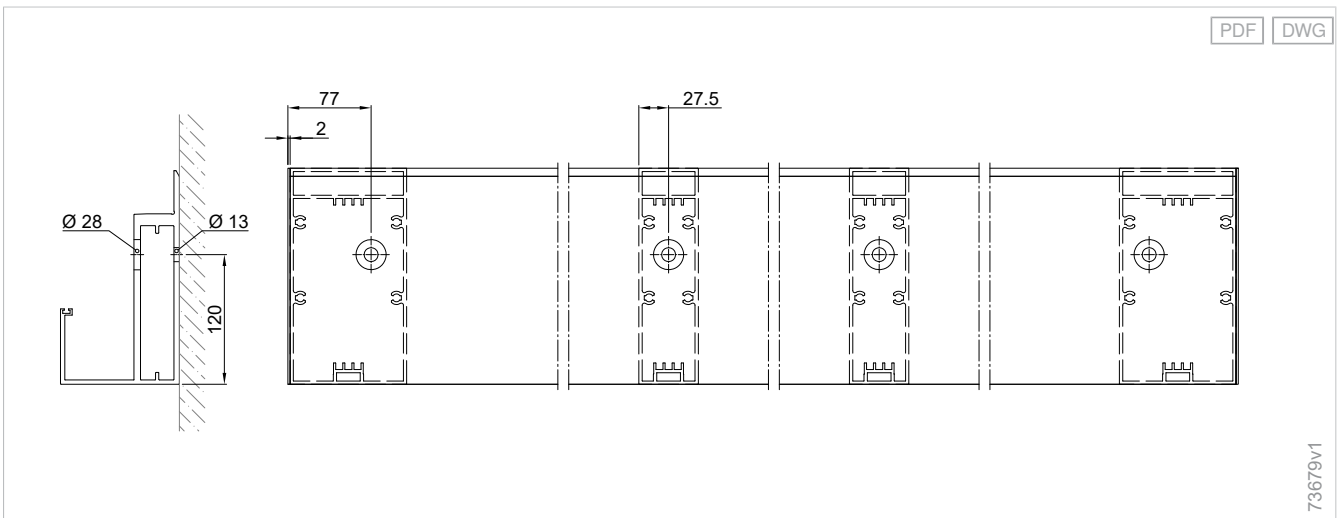

Unilateral wall connection - L50 View

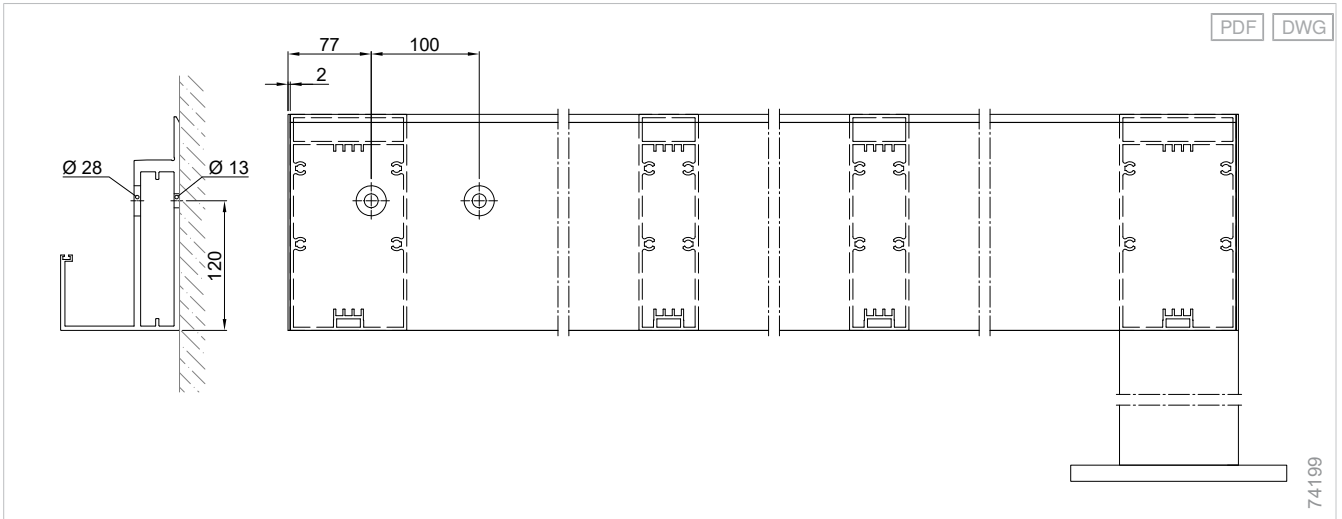

Planning

Slat roofs
Lamaxa

Glass roofs
Lamaxa

Fabric roofs
Lamaxa

Supplementary
accessories

Drive
variants

Standards

Contents

Fabric roofs Lamaxa

Fabric roofs Lamaxa L50 Tex..... 132

Planning

Slat roofs
Lamaxa

Glass roofs
Lamaxa

Fabric roofs
Lamaxa

Supplementary
accessories

Drive
variants

Standards



Fabric roofs Lamaxa

Fabric roofs Lamaxa L50 Tex

Protective

Shading can be regulated along the path of the roof product and lateral light gaps are prevented thanks to the tried and tested secudrive® guidance.

Stylish

Smart sun shading system as an eye catcher: the Lamaxa slat roof system with fabric makes quite an impression with its sleek design. A wide range of frame and fabric colours makes the combination a functional design element.

Combined

Flair with variety: the combination of different roof systems, such as the L50 Tex with fabric and the L50 with slats, generates different lighting effects and creates a varied, individually designed atmosphere. The area can be used in a more versatile way.

Construction limit values

Maximum order width	4000 mm
Maximum order length	6000 mm
Maximum order area	24 m ²

Order here

myWAREMA

[Art.-Nr. 2040238](#)

WAREMA tools

[Sun Shading Planner](#)

[+ see "Navigating the document", Page 5](#)

Components

Lamaxa L50 Tex

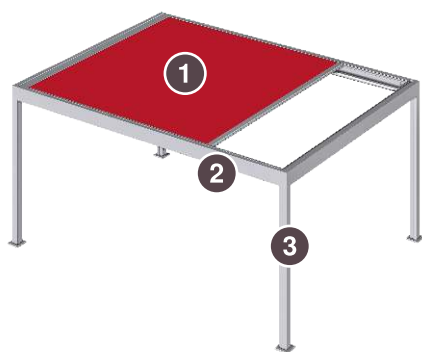

- 1 Awning fabric 3 Pole
2 Crossbeam

Pole

Pole - L50

Material	Aluminium, extruded
Surface	Powder-coated
Material, notes	one-piece
Width	110 mm
Height	110 mm

Installation options:

- Ground installation with frost-proof, on-site foundation.
- The grout for filling the clearance is not included in the scope of delivery when threaded rods are used.

Base plate

Base plate - L50

Material	Galvanised steel
Surface	Plain
Optional surface	Powder-coated
Width	200 mm
Height	200 mm

Crossbeam

Crossbeam - L50

Material	Aluminium, extruded
Surface	Powder-coated
Width	110 mm
Height	230 mm

Electrical distribution on the crossbeam, field c - L50

Material	Aluminium, folded
Surface	Powder-coated
Width	91,5 mm
Height	155 mm

Used as soon as one or more electronic accessory variants (e.g. LED strips, GranTex with easyZIP guidance) are selected. If no electronic accessories are selected, the connection is made by cable in the crossbeam.

Drainage

Drainage in pole - L50

- Drainage through drainpipe in pole.

Position of drainage outlet:

- Possible on every pole.
- Drainage and electronics/connecting lines must always be installed in separate poles.
- On the outsides of the poles or downward.
- Min. height.: 120 mm.
- Max. height: 200 mm below the headroom.

Wall connection profile, optional

Wall connection profile with small rain hood

Material	Aluminium, extruded
Surface	Powder-coated
Width	54 - 65 mm
Height	48 mm
Dimensions, notes	The adjustment range in the depth between rain hood and wall connection profile is up to 11 mm.

The on-site sealing is the responsibility of the specialist partner; if necessary, the commissioning of a plumbing company is recommended.

Field of application:

- Terrea K50
- Terrea K70
- Perea P20 (up to an angle of 10°)
- Lamaxa L50/L60/L70

Console, optional

Wall console - L50

Material	Galvanised steel
Surface	Powder-coated
Width	75 mm
Height	177 mm
Depth	105 mm

- Use in corner as pole replacement.
- A maximum of two poles can be replaced by wall consoles.
- For a concrete mounting substructure; adapter plates are required for other substructures.
- The wall console protrudes 8 mm beyond the order width and order length. This results in a gap of 8 mm between the crossbeam and the wall.

Drive variants

- Motor

Motor

- WMS-LP (WMS)

+ see "Drive variants", Page 201

Colours

- WAREMA Colour World, Individual category, fine texture surface quality
- WAREMA Colour World, Highlight category, fine texture surface quality
- WAREMA Colour World, Variation category, fine texture surface quality

Colours, optional:

- WAREMA Colour World

+ see "Colours and finishes", Page 10

Fabric qualities

- Acrylic fabric

Notes

Limit position learning:

The WAREMA Smart programming cable is required to set the motor limit positions.

Operation and control:

To ensure convenient and fast operation of the product, we recommend WMS WebControl pro (control via smartphone, tablet, etc.) and WMS Weather station plus in order to use the control modes (e.g. sun control). To do so, a sufficiently strong radio reception must be ensured.

Number of optional extras per field:

Only one optional extra is possible per field. Either GranTex with easyZIP guidance, LED on the poles, sliding shutters with wooden or aluminium filling or the SL20e glass sliding system.

Supplementary accessories

- Design radiant heater
- GranTex with easyZIP guidance
- Glass sliding system SL20e
- Sliding shutters - L50/L60/L70
- Lamaxa lighting
- Offset pole - L50/L50 Tex
- Additional pole - L50

+ see "Supplementary accessories", Page 143

Construction limit values

Configuration variants	Minimum order width	Maximum order width	Minimum order length	Maximum order length	Maximum order area	Minimum headroom	Maximum headroom
Fabric qualities							
Acrylic fabric	2500 mm	4000 mm	2000 mm	6000 mm	24 m ²	800 mm	2700 mm

Following enquiry, deviations from the standard construction limit values are possible (within limits).

Headroom/pole height:

- The minimum height for poles with drainage is 800 mm.
- The minimum height for poles without drainage is 800 mm.
- The maximum pole height (headroom plus floor recess) is ≤ 3000 mm.

Dimension determination

Field definition - L50 Tex

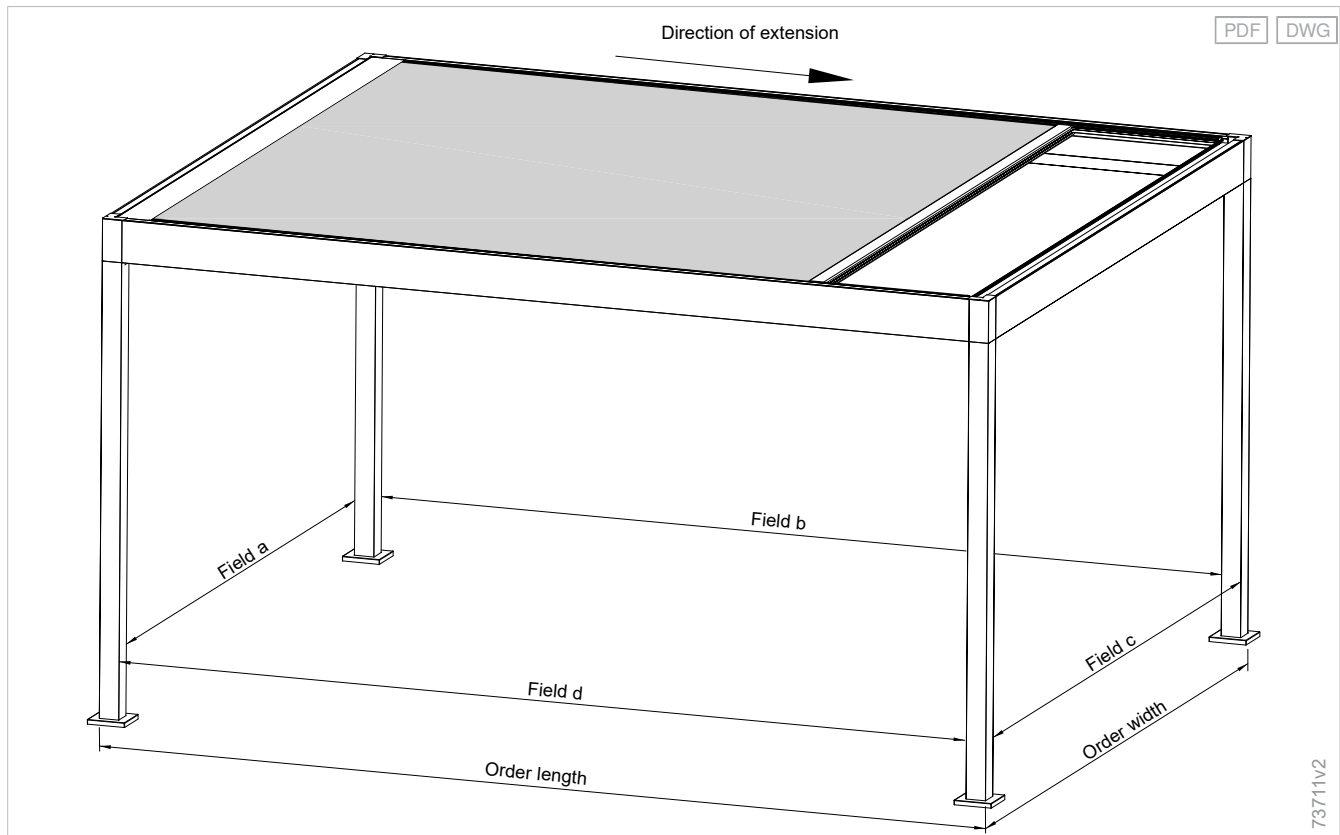

Top view of the position/connection points - L50/L60/L70

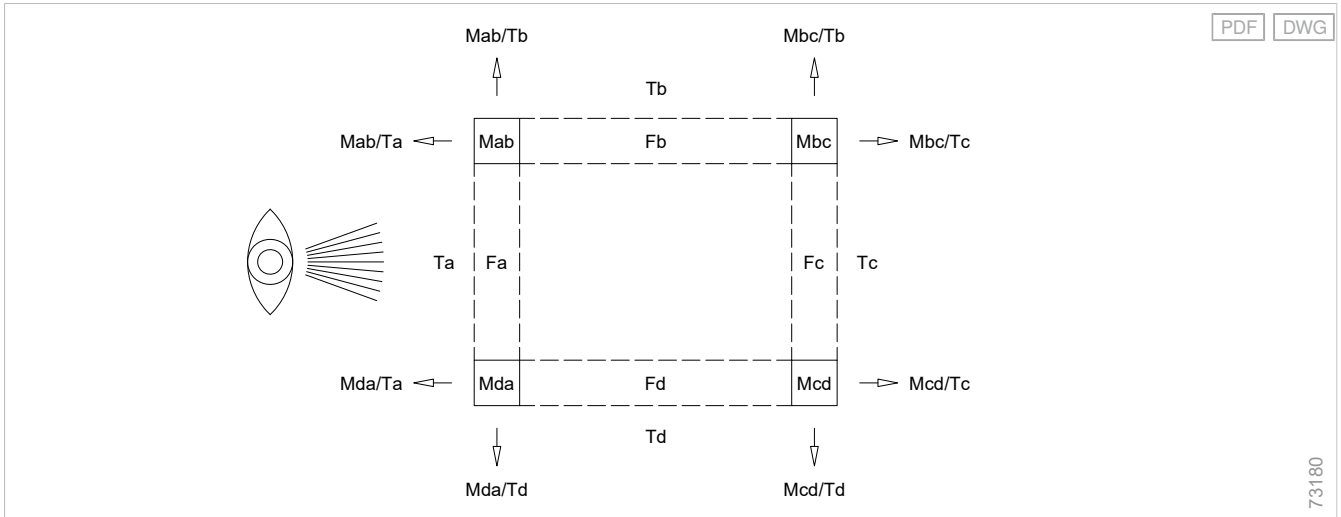

F Field T Crossbeam
M Point of installation (pole or wall connection)

Side view - L50 Tex



Side view of wall connection with wall console - L50 Tex

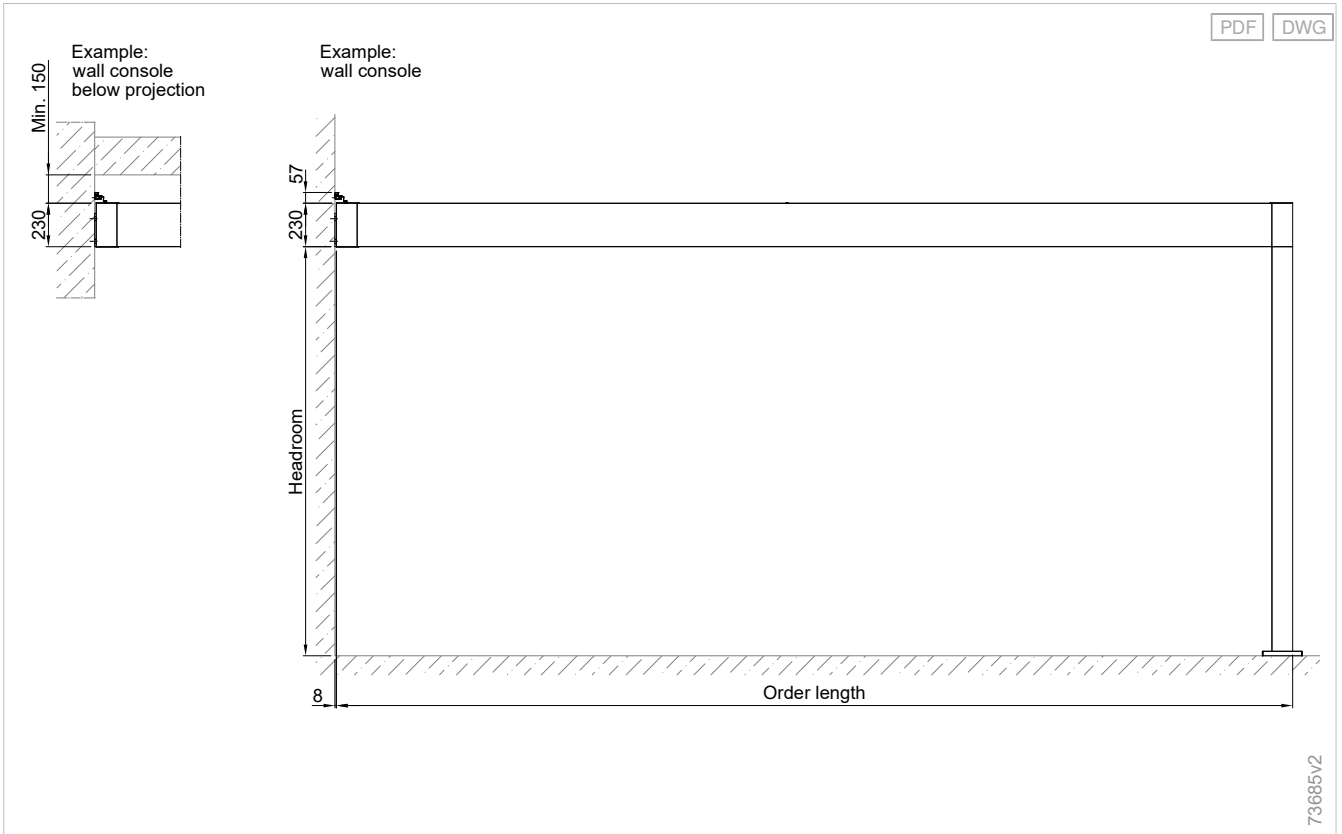

Planning

Slat roofs
Lamaxa

Glass roofs
Lamaxa

Top view for individual units - L50 Tex

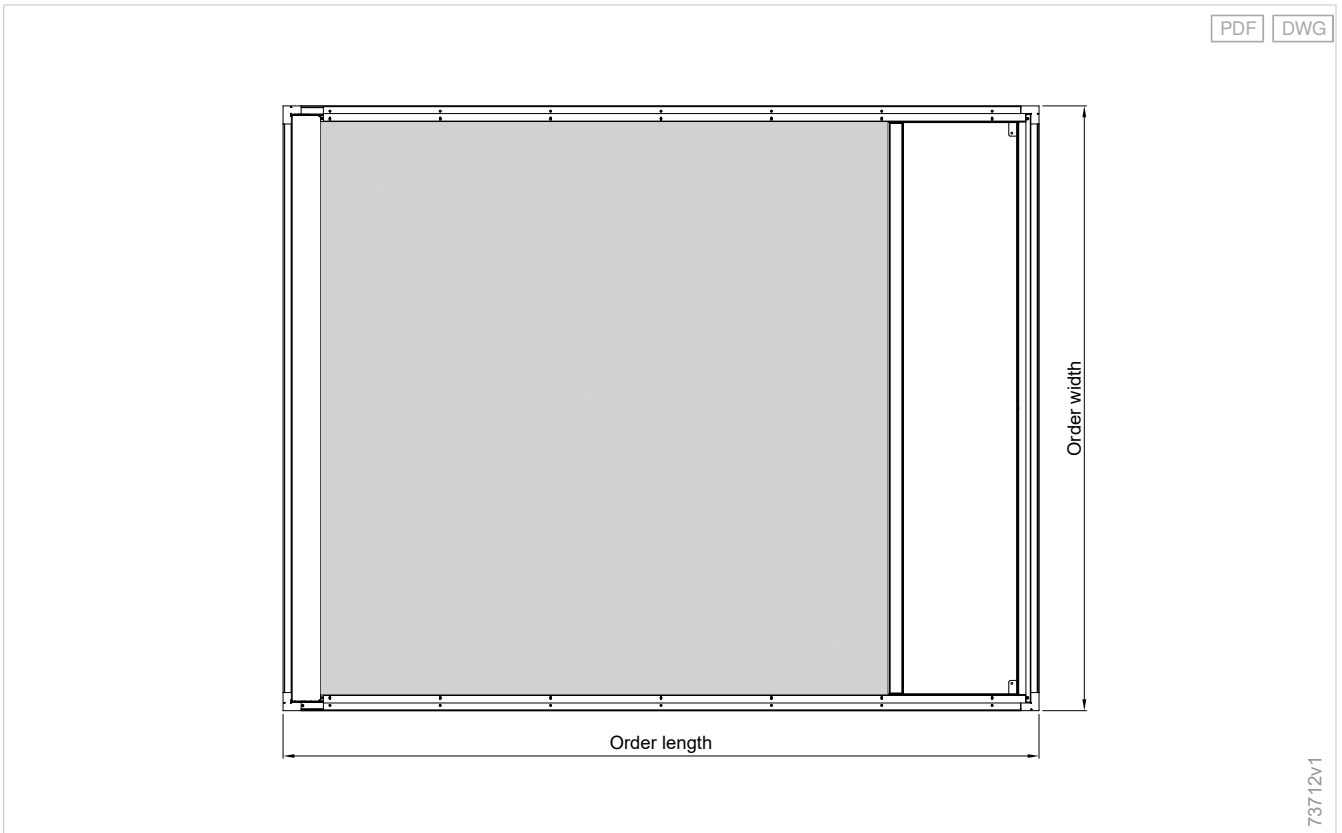

Fabric roofs
Lamaxa

Supplementary
accessories

Drive
variants

Standards

Weight assessment

Weight assessment for roof systems

Order length	Order width			
	2000 - 2500 mm	2501 - 3000 mm	3001 - 3500 mm	3501 - 4000 mm
2500 mm	159 kg	171 kg	183 kg	195 kg
3000 mm	170 kg	182 kg	194 kg	207 kg
3500 mm	182 kg	194 kg	206 kg	218 kg
4000 mm	194 kg	206 kg	218 kg	230 kg
4500 mm	205 kg	218 kg	230 kg	242 kg
5000 mm	217 kg	229 kg	242 kg	254 kg
5500 mm	229 kg	241 kg	253 kg	266 kg
6000 mm	240 kg	253 kg	265 kg	278 kg

Details

Rectangular cover panel and front rail

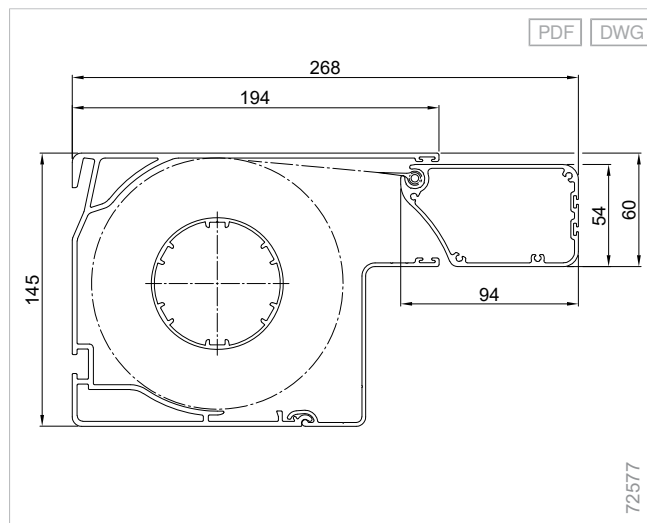

Crossbeam with LED profile - L50

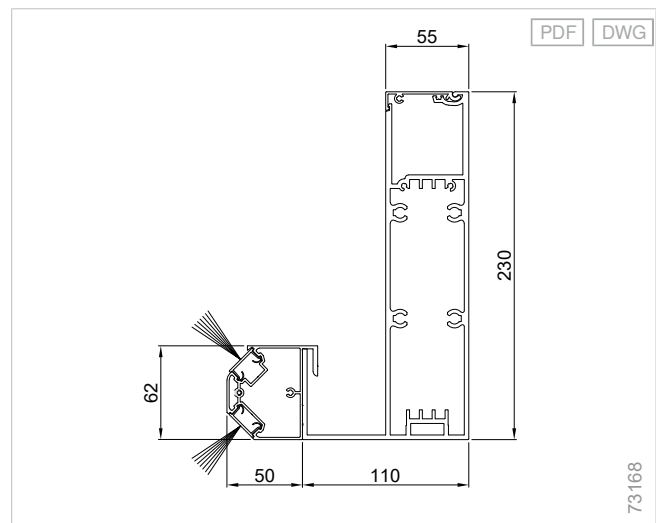

Crossbeam - L50

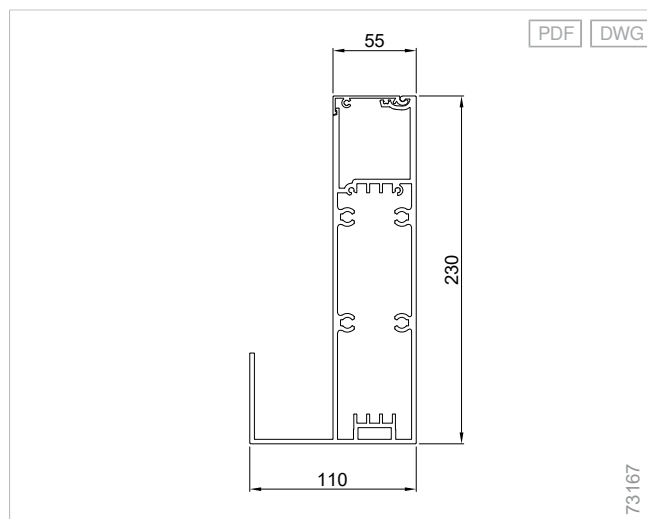

Connection box (electrical distribution on the crossbeam) - L50 Tex

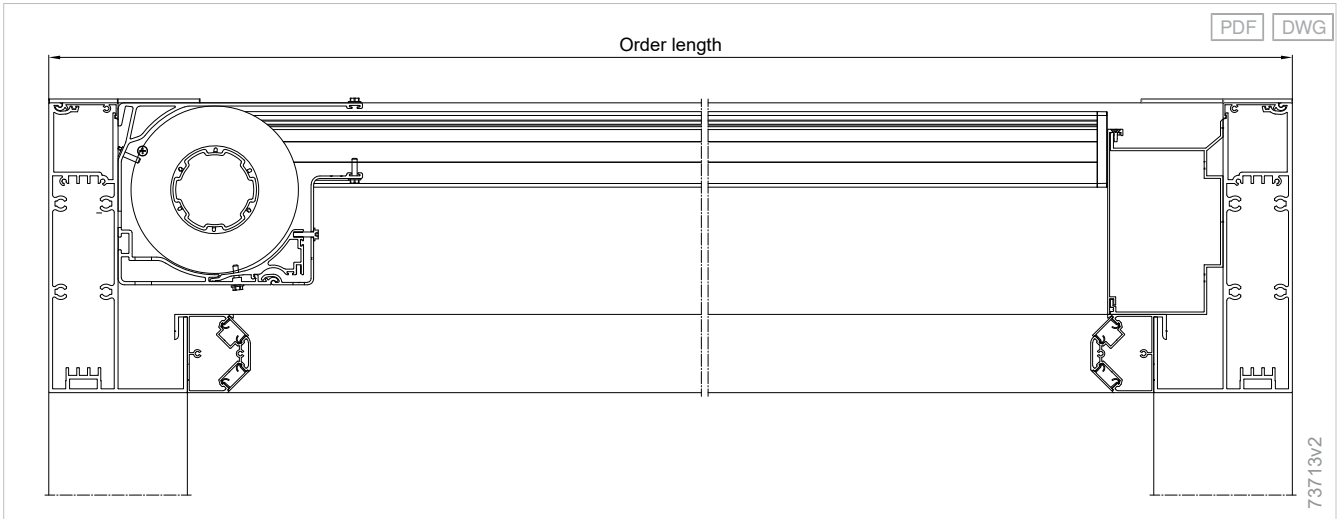

Pole - L50

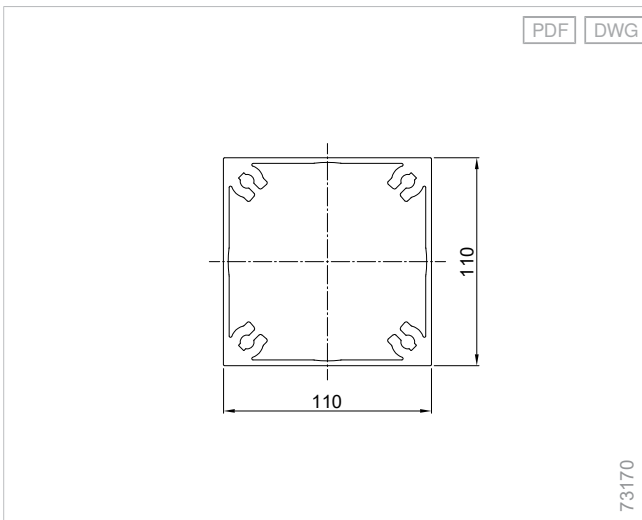

L50, rectangular drainage

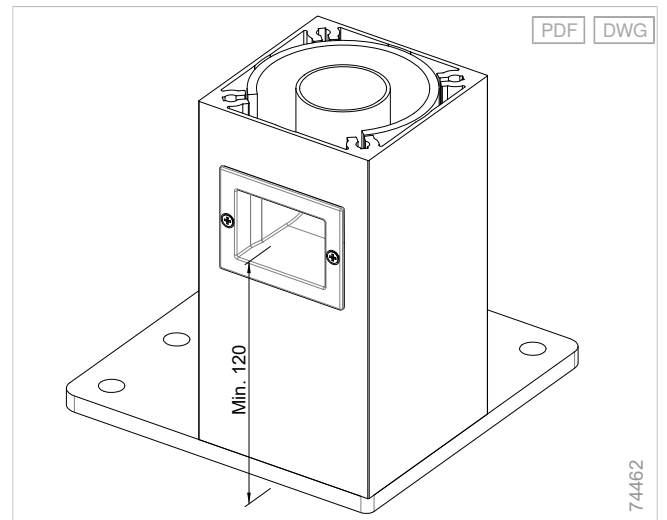

L50, position of drainage, on-site

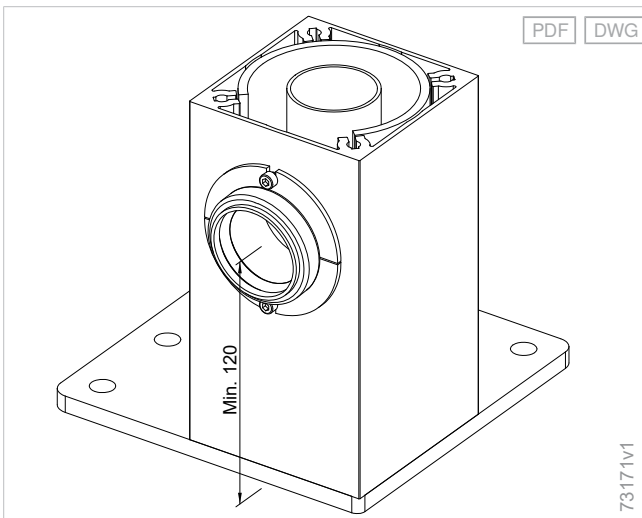

L50, rectangular drainage, optional waterspout

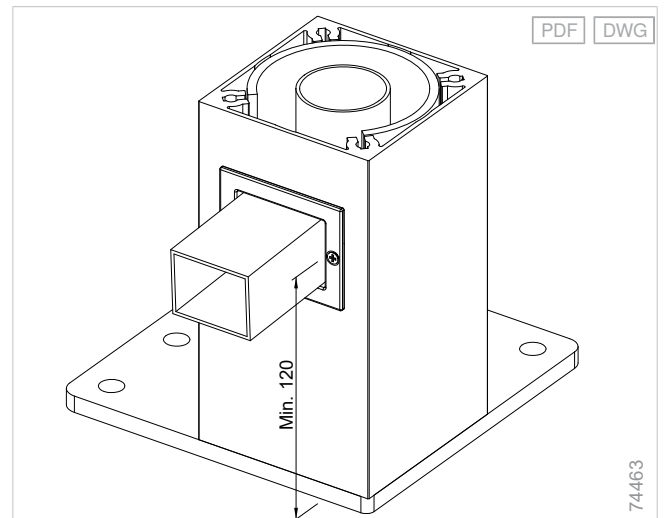

Planning

Slat roofs
Lamaxa

Glass roofs
Lamaxa

Fabric roofs
Lamaxa

Supplementary
accessories

Drive
variants

Standards

Base plate - L50

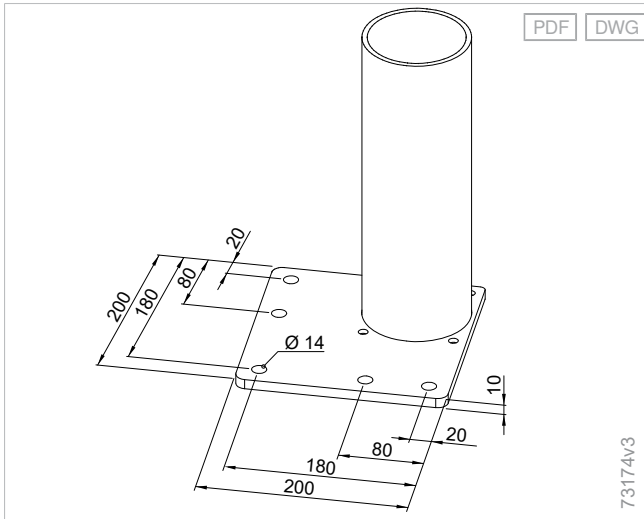

Wall connection profile with small rain hood - L50/L60/L70

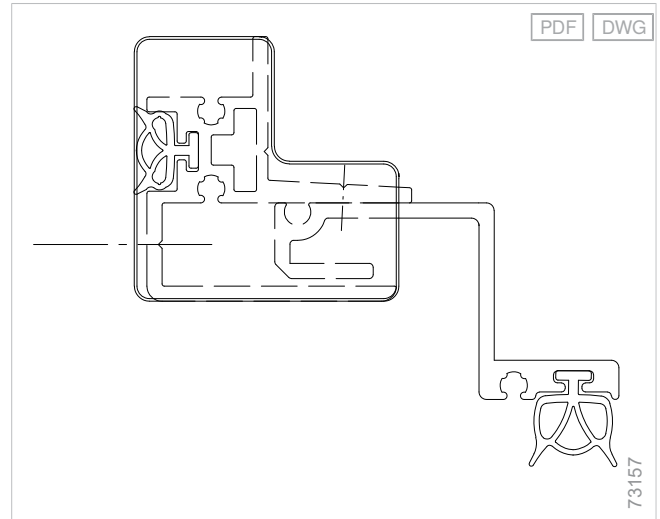

Corner installation base cover - L50

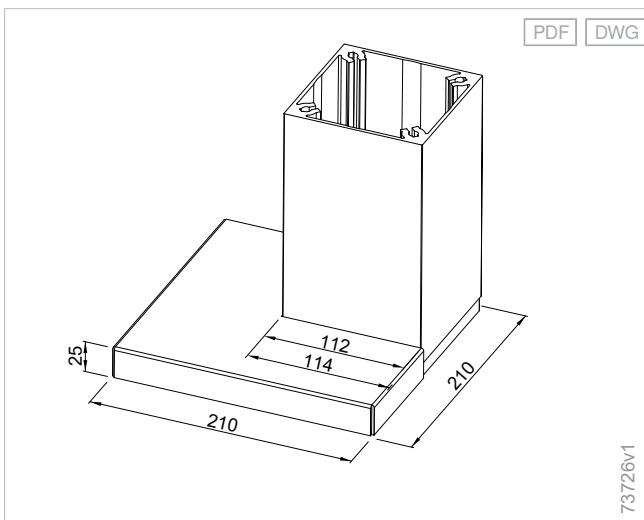

Recess installation base cover - L50

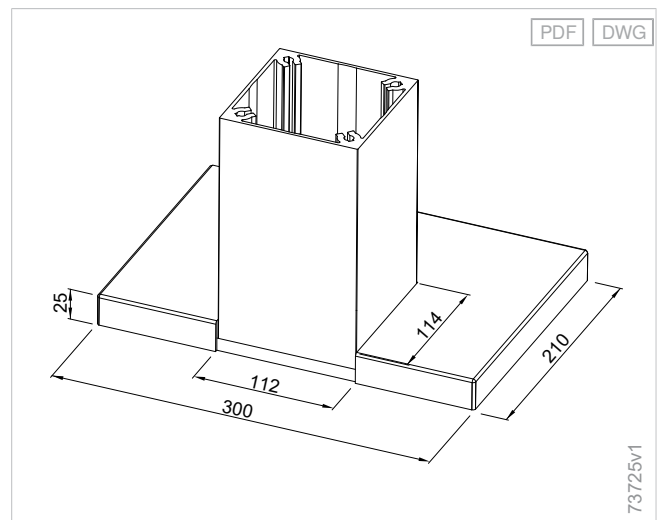

External base cover - L50

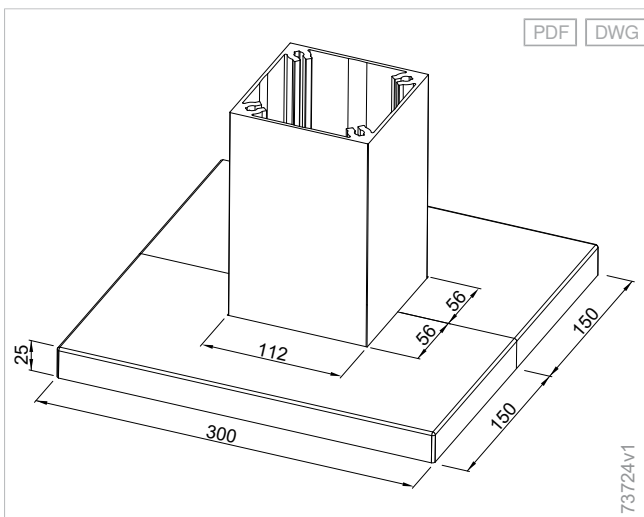

Additional product information

Pole installation options

Ground installation with frost-proof on-site foundation, see slat roof guidelines (IVRSA).

Mounting examples

Application of base plate for recess installation - L50

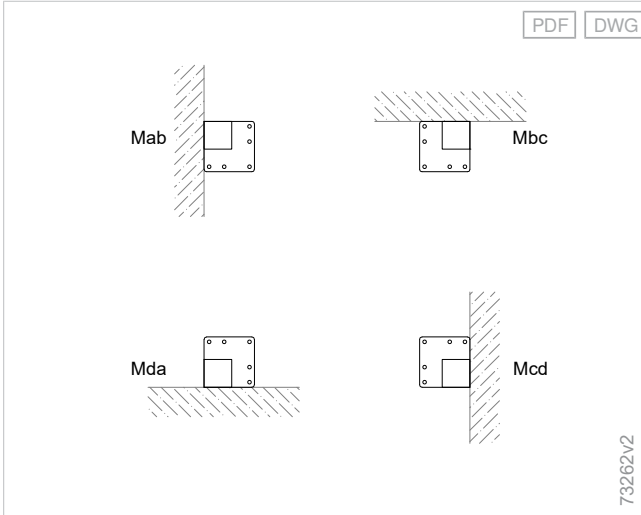

M Point of installation (pole or wall connection)

Application of corner installation base plate - L50

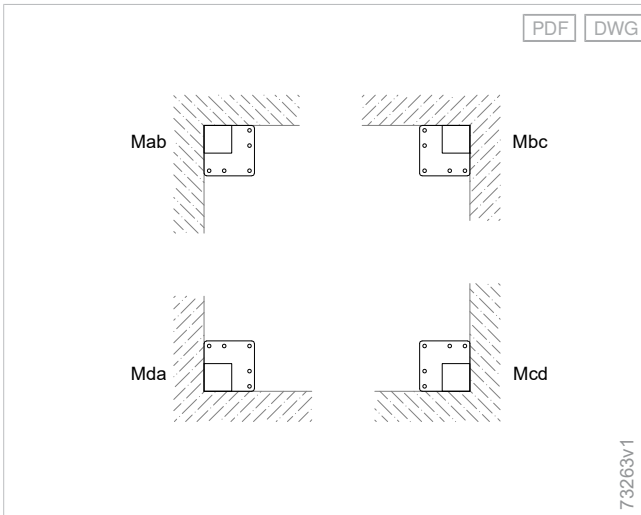

M Point of installation (pole or wall connection)

Fixing on concrete foundation

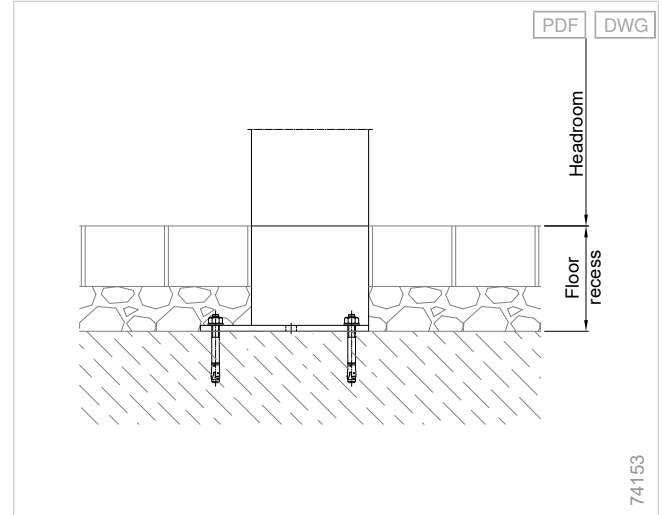

Fixing on concrete foundation (corner installation)

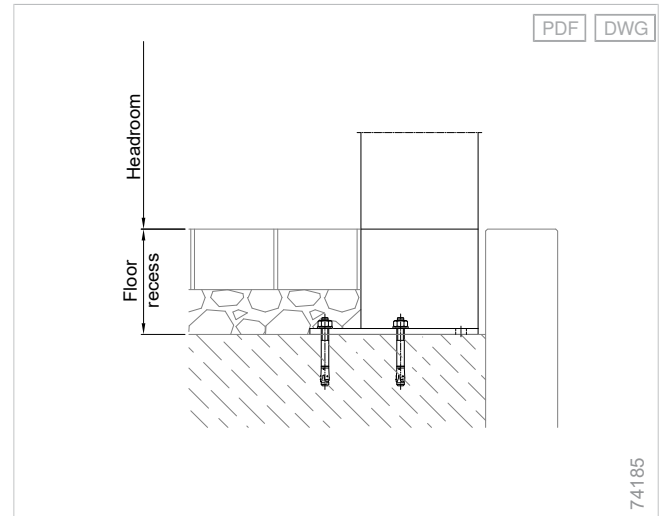

Design radiant heater on crossbeam - L50

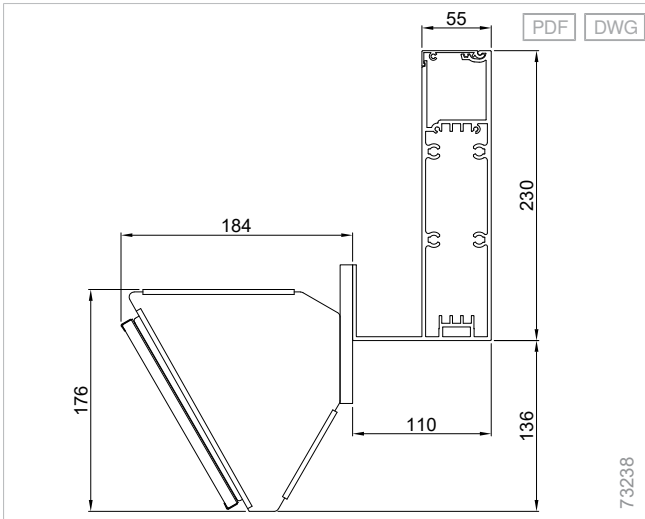

Side view of wall connection - L50 Tex

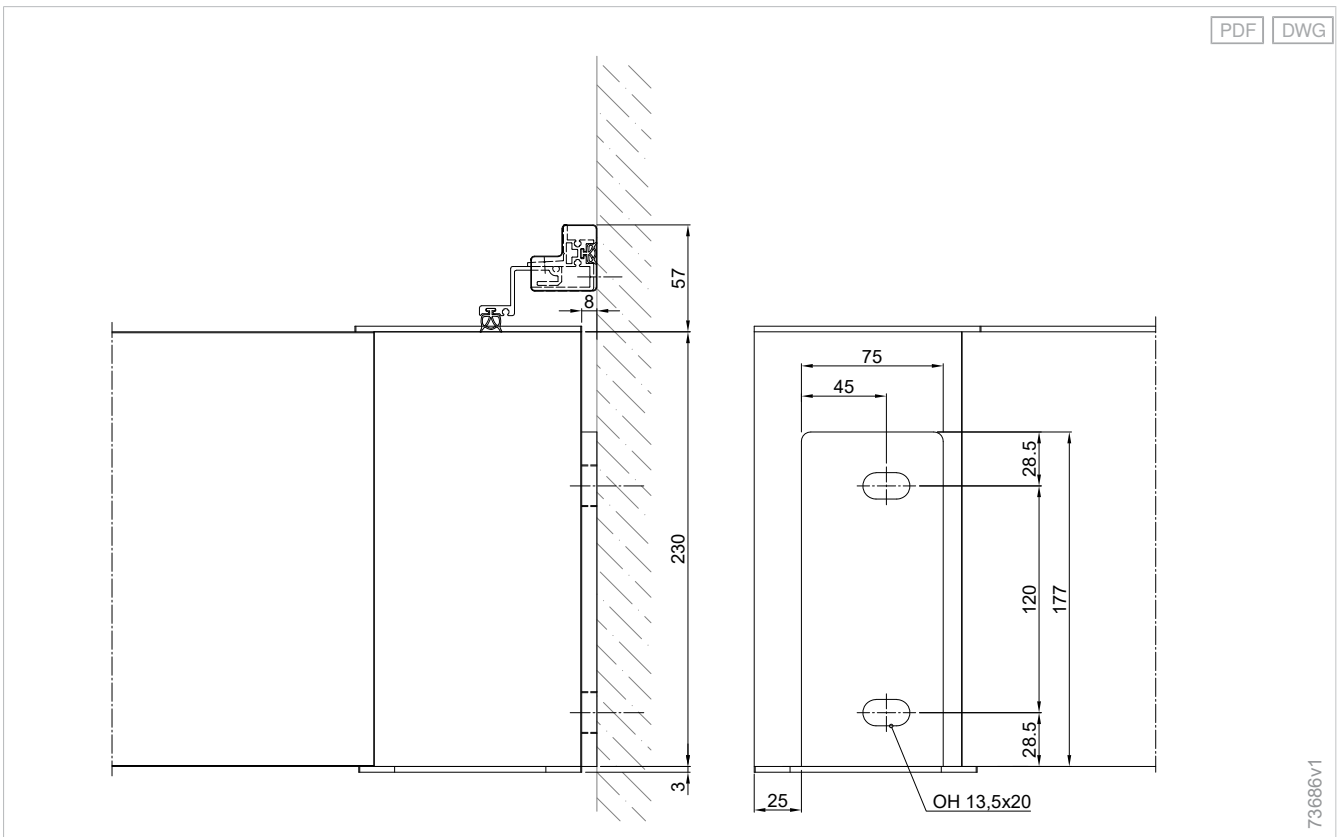

Contents

Supplementary accessories

Design radiant heater.....	144
Lamaxa lighting.....	148
LED lighting - L50/L60/L70.....	149
RGB lighting - L50/L60/L70.....	152
Shading systems.....	154
Integrated awnings with easyZIP guidance.....	155
GranTex with easyZIP guidance.....	157
Components.....	162
Conservatory awnings Climara W10.....	164
Conservatory awnings Climara W20.....	168
Sash frames.....	172
Glass sliding system SL20e - L50/L60/L70.....	173
Sliding shutters L50/L60/L70.....	179
Additional pole.....	186
Additional pole - L60/L70.....	187
Additional pole - L50.....	190
Offset pole.....	192
Offset pole - L60/L70.....	193
Offset pole - L50/L50 Tex.....	195
Power socket.....	196
Protection profile.....	198

Planning

Slat roofs
Lamaxa

Glass roofs
Lamaxa

Fabric roofs
Lamaxa

Supplementary
accessories

Drive
variants

Standards



Supplementary accessories

Design radiant heater

Modern

With its tinted glass ceramics and the flat housing, the Design radiant heater has an especially modern look.

Coordinated

Harmonious colour coordination: The entire WAREMA Colour World is available for your Design radiant heater. The colour of the housing can be matched to your sun shading product.

Efficient

With a width of 974 mm and output of 2200 watts, the Design radiant heater quickly and effectively warms patio areas.

Can be used for:

- Terrea articulated arm and cassette awnings
- Perea pergola awnings
- Climara conservatory awnings
- Lamaxa slat roofs



Product characteristics

- Optional dimming function
- Attractive design
- Operation via hand-held transmitter



Colours

- WAREMA Colour World

+ see "Colours and finishes", Page 10

Product characteristics

Power	2200 W
Operation	Optionally with switch or WMS radio remote control.
Attachment	Possible on the slat roof or the building wall.
Operating voltage	230 V AC
Degree of protection	IP 65
Width	974 mm
Height	176 mm
Weight	8 kg
Inclination angle	30 - 40 °

Product characteristics

- Infrared short wave radiant heater
- Reduced red light radiation thanks to black glass ceramic cover
- Powder-coated housing
- Can optionally be dimmed via WMS dimmer 0-10 V

Notes

Minimum distance:

- In the lighting area, the minimum distance to flammable materials must be at least 1000 mm.
- For awnings with a valance or valance roller blind, the radiant heater may only be operated when the awning is extended.
- The use of a radiant heater with awnings with a superordinate electronic control and a manual valance roller blind, for example, is not recommended.
- The radiant heater is only suitable for outdoor use and must be mounted horizontally.
- Please observe the safety instructions in the installation and operating instructions.

Fuse required: Please note when planning that a separate fuse C16 is required for radiant heaters.

Quantity:

- L50: max. 2 Design radiant heaters (crossbeam a and/or c)
- L60/L70: max. 4 Design radiant heaters (crossbeam a, b, c and/or d)

Max. 2x radiant heaters or 1x radiant heater in combination with 1x power socket can be directly connected to the Lamaxa electrical distribution. Anything beyond this must be implemented on-site (separate connecting line).

Radiant heater in combination with LED/RGB profile:

The radiant heater cannot be combined with the LED/RGB profile on the crossbeam.

Radiant heater in combination with protection profile:

The radiant heater cannot be combined with the protection profile.

Power socket in combination with radiant heater: The power socket can be combined with a maximum of one radiant heater! A separate connecting line is required if more than one radiant heater is installed.

Details

Design radiant heater

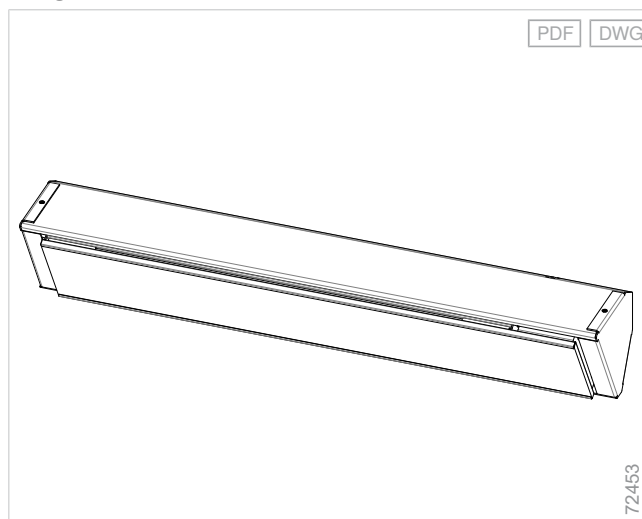

Mounting examples

Wall installation - design radiant heater

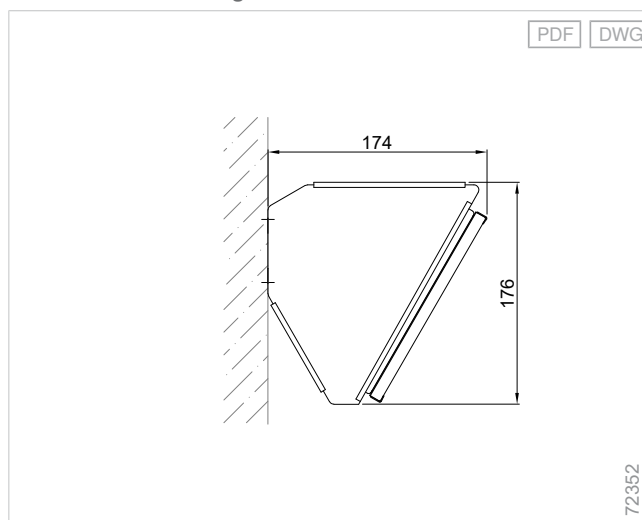

Design radiant heater mounting position

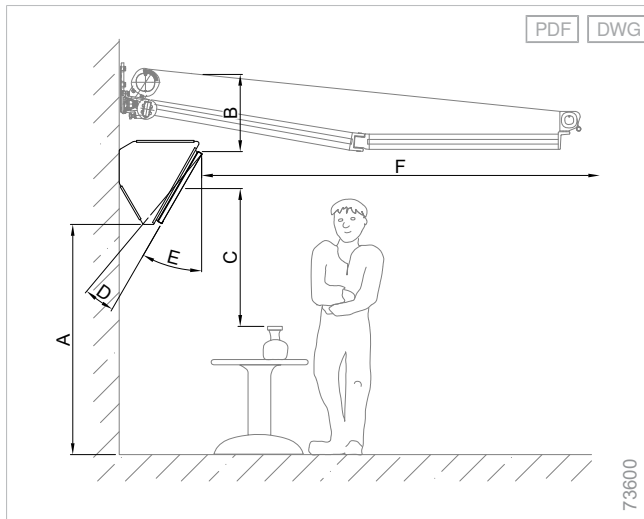

- | | | | |
|---|----------------------------------------------------------------------|---|--------------------------------|
| A | Minimum distance from the floor is 2100 mm | D | Continuously adjustable to 40° |
| B | Minimum distance toward the top is 240 mm and to the sides is 600 mm | E | Standard inclination 30° |
| C | Minimum distance downward to flammable material is 1000 mm | F | Distance forward is 1500 mm |



Supplementary accessories

Lamaxa lighting

Dimmable

For individual lighting moods: The WMS dimmer sets the LED strips to the desired brightness, ranging from soft ambient lighting to bright reading lighting.

Smart

Wireless operation: The lighting can be switched on and off and dimmed using a hand-held transmitter.

Colourful

Coloured lighting to match your mood: The indirect RGB lighting can be set to any colour.

Can be used for:

- Lamaxa L70
- Lamaxa L60
- Lamaxa L50



Product characteristics

- Depending on the type of slat roof, the LED lighting can be attached in a number of ways. For example, integrated or surface-mounted models with direct and/or indirect attachment are available.
- The RGB lighting, which can be used for indirect lighting, adjusts the light colour to suit the mood.

LED lighting - L50/L60/L70

Can be used for:

- Lamaxa L70
- Lamaxa L60
- Lamaxa L50

Set

Lens - LED strips

LED strip

Operating voltage	24 V DC
Total power of light	400 running metre per metre, 4.8 W/m
Degree of protection	IP 67
Durability	Approx. 10000 operating hours
Colour temperature	3000 K

LED strip profile

Material	Aluminium, extruded
Surface	Powder-coated
Width	50 mm
Height	62 mm

Power supply unit - integrated lighting Lamaxa

Degree of protection	IP 54
----------------------	-------

Notes

Notes on product configuration

L50: If LED or RGB lighting is selected, a junction box on the crossbeam is absolutely necessary for electrical distribution (see surcharge for L50).

Unlit area: The RGB strips are assembled in increments of 50 mm. This can lead to an unlit area of max. 100 mm per side.

Radiant heater in combination with LED/RGB profile:

The radiant heater cannot be combined with the LED/RGB profile on the crossbeam.

Dimension determination

Top view of the position/connection points - L50/L60/L70

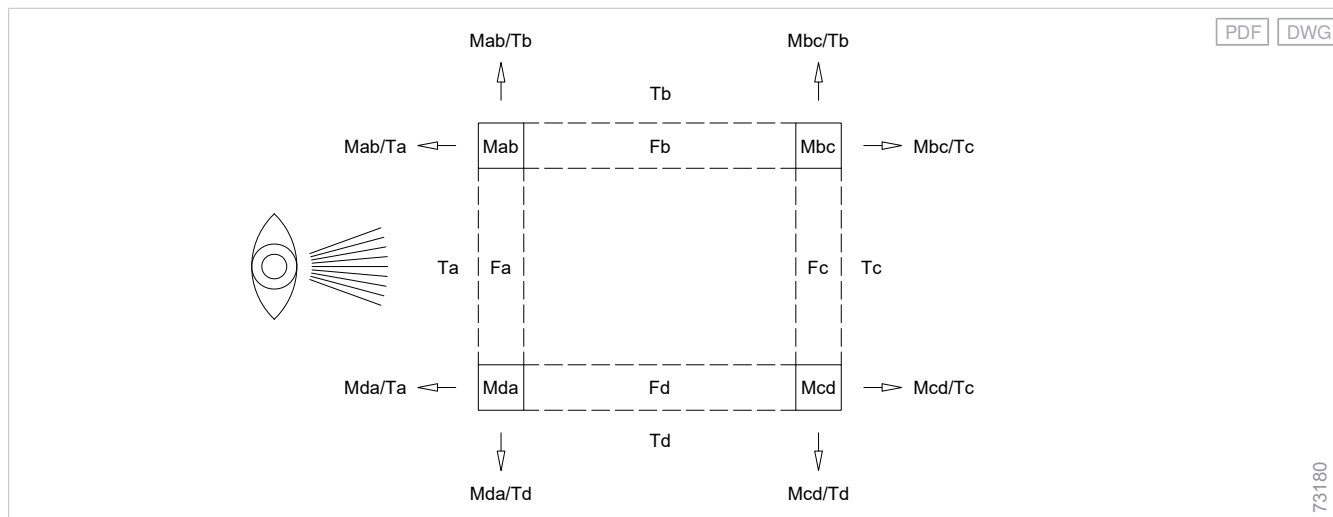

F Field
M Point of installation (pole or wall connection)
T Crossbeam

Crossbeam with LED profile - L50

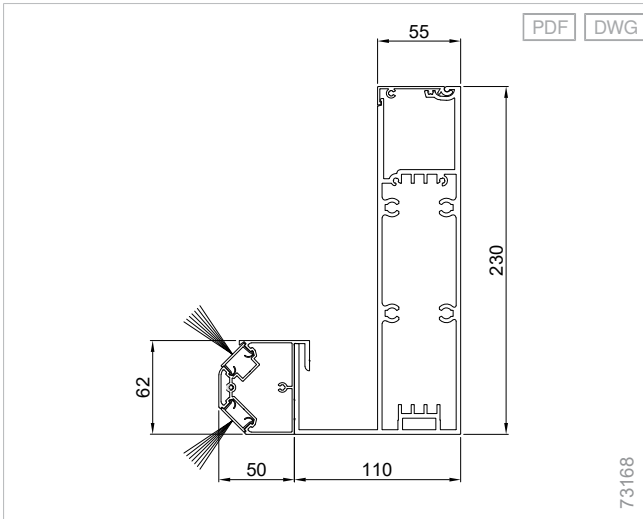

L70, crossbeam b/d, optional LED profile

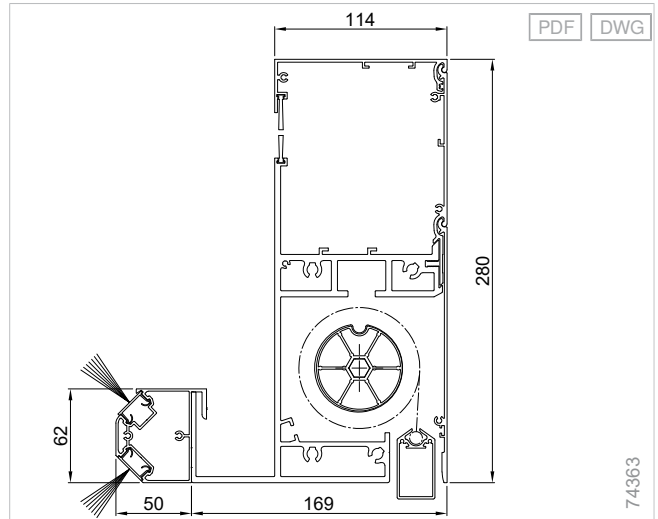

L50/L60, LED slat



Rafter with integrated LED strip - L50 View

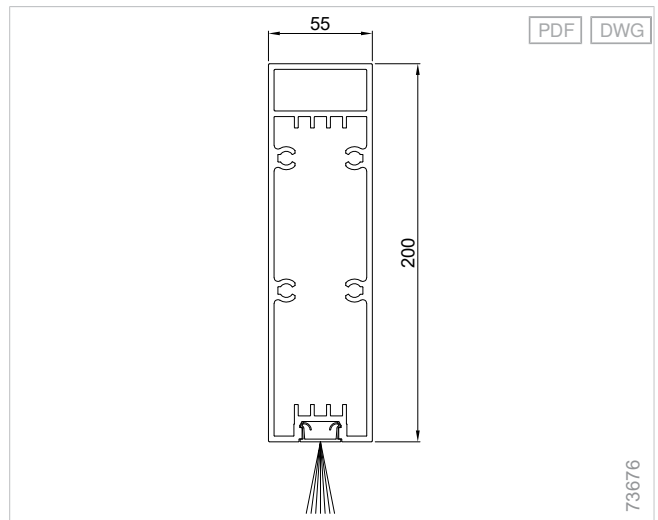

L60/L70, poles with integrated LED lighting

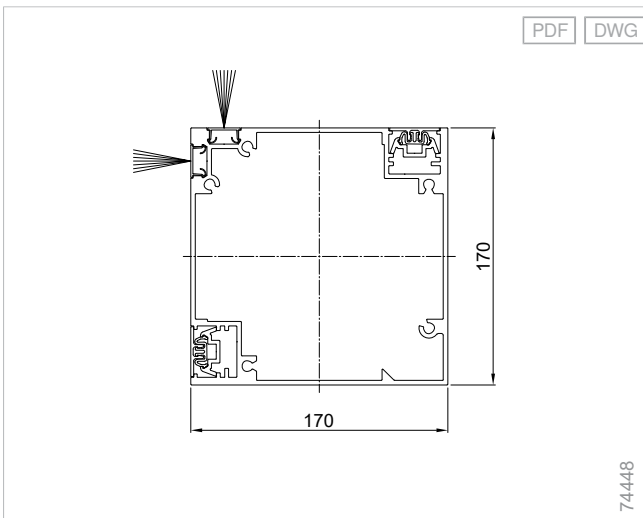

LED lighting on pole - L50

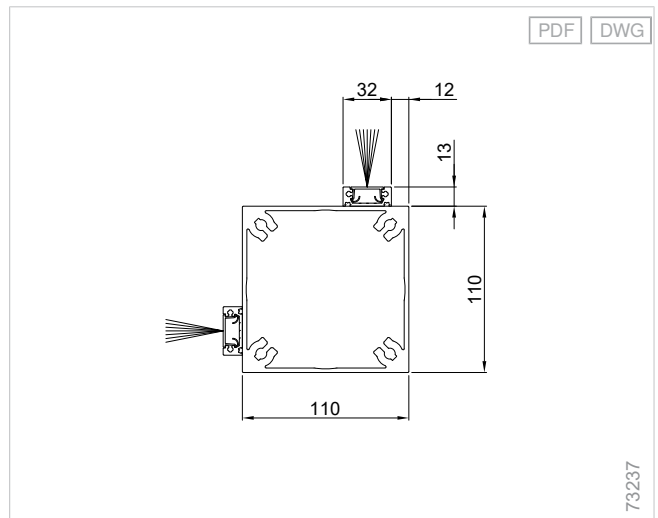

Additional product information

Use of Lamaxa LED lighting

	L70	L60	L50	L50 View	L50 Tex
Two-sided LED lighting on the crossbeam - direct and/or indirect (crossbeams b and d)	X	X	X	-	X
Four-sided LED lighting on the crossbeam - direct and/or indirect (crossbeams a to d)	X	X	X	-	X
LED lighting in pole	X	X	-	-	-
LED lighting on pole	-	-	X	X	X
LED lighting in the slat(s) (max. 4 slats)	-	X	X	-	-
LED lighting in rafters	-	-	-	X	-

Prefitting for lighting - L60/L70

A corresponding prefitting for lighting is required to retrofit LEDs in the pole. Without this prefitting, subsequent LED lighting in the pole is not possible.

All lines required for the product are supplied and have to be laid in the slat roof during installation, also for the prefitted version. Only lines that have a power consumer can be connected in the motor operation distribution system. For this reason, the lines for the prefitted variant must not be connected.

Position	Prefitting components
Field a-d	Connecting line and 24 V DC distributor

RGB lighting - L50/L60/L70

Can be used for:

- Lamaxa L70
- Lamaxa L60
- Lamaxa L50

Set

Lens - LED strips

RGB strip

Operating voltage	24 V DC
Total power of light	12 W/m
Degree of protection	IP 54
Durability	Approx. 25000 operating hours

LED strip profile

Material	Aluminium, extruded
Surface	Powder-coated
Width	50 mm
Height	62 mm

Additional product information

Use of RGB lighting for Lamaxa

	L70	L60	L50	L50 View	L50 Tex
Two-sided RGB lighting on the crossbeam - indirect (crossbeams b and d)	x	x	x	-	x
Four-sided RGB lighting on the crossbeam - direct and indirect (crossbeams a to d)	x	x	x	-	x

Power supply unit - integrated lighting Lamaxa

Degree of protection IP 54

Notes

Notes on product configuration

L50: If LED or RGB lighting is selected, a junction box on the crossbeam is absolutely necessary for electrical distribution (see surcharge for L50).

Unlit area: The RGB strips are assembled in increments of 50 mm. This can lead to an unlit area of max. 100 mm per side.

Radiant heater in combination with LED/RGB profile:

The radiant heater cannot be combined with the LED/RGB profile on the crossbeam.



Supplementary accessories

Shading systems

Lateral protection

More privacy: practical lateral visual privacy, sun shading and wind protection for pleasant hours on the patio. For an all-round shielded time outdoors, all four sides can be fitted with an integrated awning.

Durable

High-grade technology: the easyZIP guidance makes for a taut appearance, with high wind stability and no lateral light gaps.

Creative

Individual design: A selection of over 300 designs is available for fabrics.

Can be used for:

- Lamaxa L70
- Lamaxa L60
- Lamaxa L50

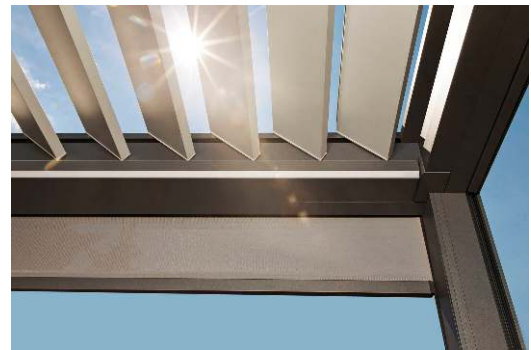

Product characteristics

- Vertical shading solutions ensure both visual privacy and serve as sun shading and wind protection
- The easyZIP guidance provides products with high wind stability

Integrated awnings with easyZIP guidance

Notes

Notes on product configuration

An integrated awning with easyZIP guidance can be used on all four fields of the Lamaxa.

We recommend the fabric quality Screen, as this creates an even fabric appearance as well as a taut fabric tension.

Notes on installation

The integrated awnings with easyZIP guidance are integrated into the crossbeam, the guide rails are

integrated into the pole. The end rail is not completely integrated into the crossbeam when retracted; this can be adjusted during installation if necessary.

The integrated awnings with easyZIP guidance are preassembled at the factory. The units simply need to be connected and learned.

The wiring for this is already prepared in the slat roof.

Construction limit values

Configuration variants	Minimum order width	Maximum order width	Minimum order height	Maximum order height	Maximum order area
Fabric qualities					
Screen fabric 4 % / 5 %	750 mm	6000 mm	950 mm	3000 mm	17,40 m ²

Dimension determination

Configuration view:

Height of integrated awnings with easyZIP guidance = Lamaxa headroom + 122 mm

Width of integrated awning with easyZIP guidance = Lamaxa order width/length - 284 mm

Width with additional pole:

Width of integrated awning with easyZIP guidance, field Faa/Fba/Fca/Fda = Laa/Lba/Lca/Lda - 115 mm

Width of integrated awning with easyZIP guidance, field Fab/Fbb/Fcb/Fdb = Lamaxa order width/length - Laa/Lba/Lca/Lda - 285 mm

Additional product information

Prefitting for integrated awnings with easyZIP guidance - L60/L70

The slat roofs L60/L70 can be prefitted for comfortable retrofitting of additional components.

All lines required for the product are supplied and have to be laid in the slat roof during installation, also for the prefitted version. Only lines that have a power consumer can be connected in the motor operation distribution system. For this reason, the lines for the prefitted variant must not be connected.

Position	Prefitting components
Field a-d	Motor line

Mounting examples

Integrated awning with easyZIP guidance - L60/L70

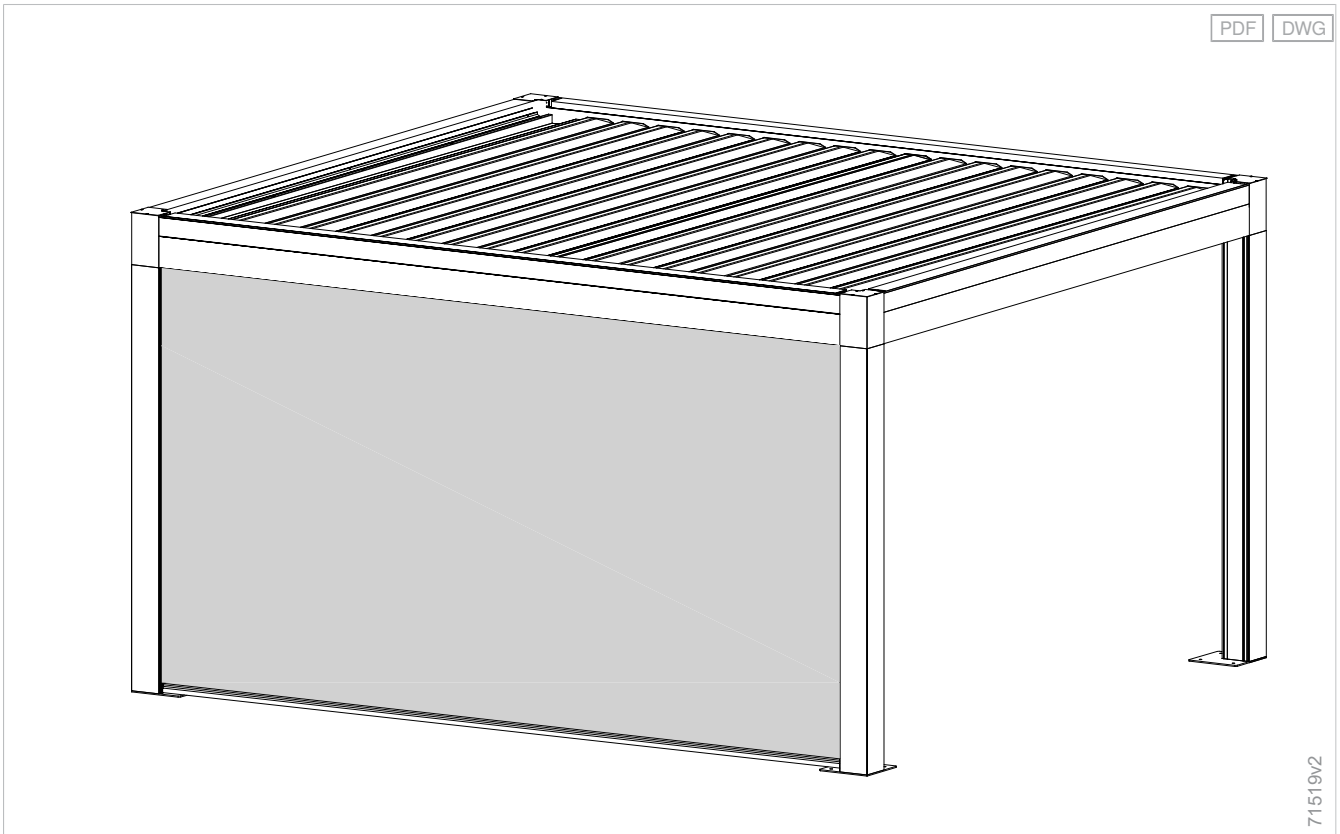

Top view of fields and poles - L50/L50 Tex/L60/L70

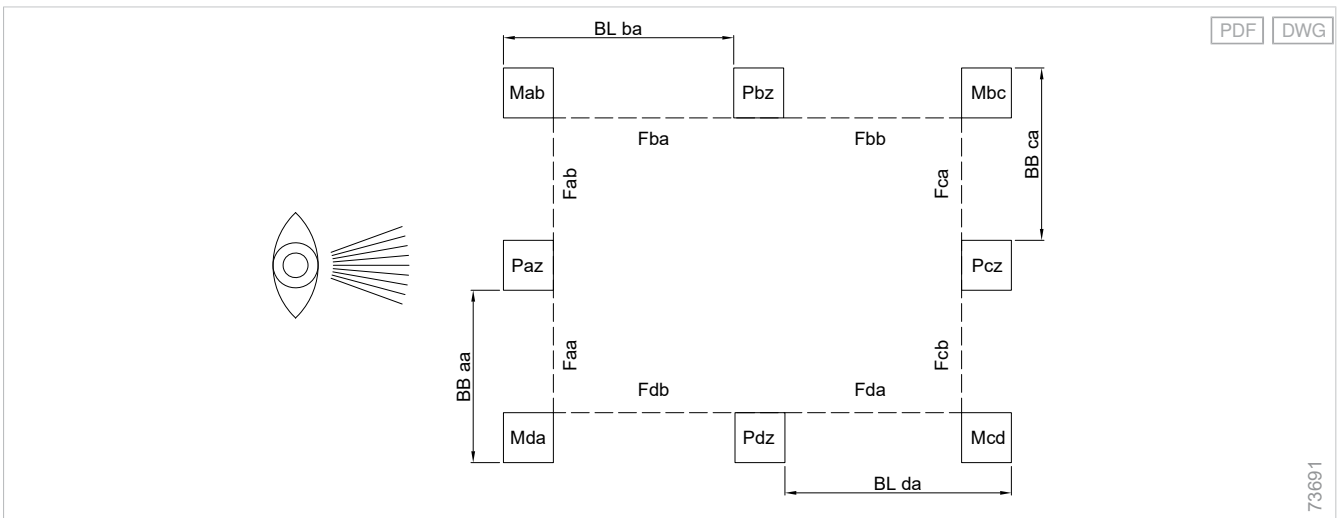

- | | | | |
|---|-------------------------------------------------|----|--------------|
| P | Pole | z | Additional |
| F | Field | BB | Order width |
| M | Point of installation (pole or wall connection) | BL | Order length |

GranTex with easyZIP guidance

Components

GranTex with easyZIP guidance

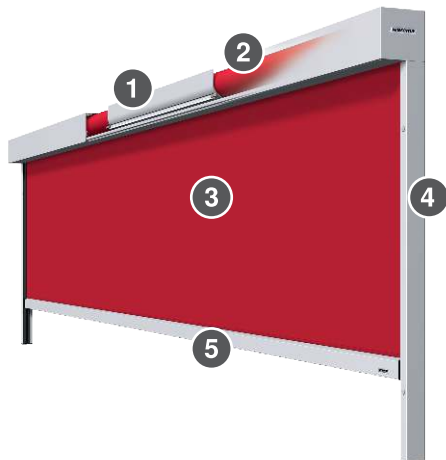

- 1 Box with fabric shaft support
- 2 Fabric shaft
- 3 Awning fabric
- 4 Lateral guidance
- 5 End rail

GranTex with easyZIP guidance - L50

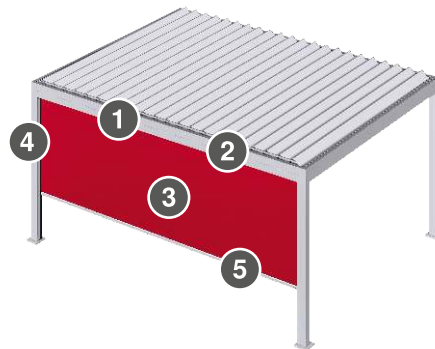

- 1 Box with fabric shaft support
- 2 Fabric shaft
- 3 Awning fabric
- 4 Lateral guidance
- 5 End rail

Box

Size 110

Box sizes	110
Unwinding direction	Left-rolling blind, Right-rolling blind
Material	Aluminium, extruded
Surface	Powder-coated
Optional surface	Anodised

Due to the large overall width, a box support is necessary. The box support can either be made by means of a wall console or by screwing the box. If the box is supported by means of a console, only a left-rolling blind is possible.

+ Side cover

Side covers for front-mounted awnings, rectangular

Material	Diecast aluminium
Surface	Powder-coated
Material, notes	If an anodised finish is selected, powder coating will be done in a similar colour.

+ Inspection cover

Inspection cover for front-mounted awning, rectangular

Material	Aluminium, extruded
Surface	Powder-coated
Optional surface	Anodised

+ Inspection cover, optional

High inspection cover

Material	Aluminium, extruded
Surface	Powder-coated
Optional surface	Anodised
Height	25 mm
Dimensions, notes	<ul style="list-style-type: none"> - Housing for plug-in connector available. - Reduced viewing height of the end rail.

Shaft

Fabric shaft Ø 62.2 mm

Material	Aluminium, extruded
Surface	Plain
Profile	Groove tube
Diameter	62.2 mm

End rail

End rail, rectangular

Height	47 mm
Depth	25 mm
Dimensions, notes	The end rail is generally visible.

Guide variants

- easyZIP guidance

Guide rail

- Guide rail T-26x110-G

Clip profile

Material	Plastic, extruded
Material colour	Black
Material colour, optional	Grey

Drive variants

Motor

- Basic motor type ZM REA

Radio motor, optional

- EWFS Radio motor type W-ZM
- WMS Radio motor type WMS-ZM

+ see "Drive variants", Page 201

Colours

- WAREMA Colour World

+ see "Colours and finishes", Page 10

Fabric qualities

- Screen fabric 4 % / 5 %
- Soltis 92

Notes

Measurement:

- The water drain must be installed on the front of or laterally on the pole.

- When using the base plate with a base cover, the GranTex with easyZIP guidance does not travel completely to the base, but instead leaves a 25 mm gap.

Wiring:

- As soon as one or more electronic accessory variants (e.g. LED strips, GranTex with easyZIP guidance) are selected for the Lamaxa slat roof, the electrical distribution is performed in a connection box on the crossbeam (field c). If no electronic accessories are selected, the connection is made by line in the crossbeam - regardless of the number of poles.
- **If a GranTex with easyZIP guidance is integrated into crossbeam b, c and d, the wiring is installed across the corner area in the pole in the connection box. If a GranTex with easyZIP guidance is attached to the opposite side of the connection box (crossbeam a), the line is routed in the crossbeam in the connection box.**

Control:

- The GranTex with easyZIP guidance can be controlled via a Lamaxa L50 WMS hand-held transmitter or via a separate hand-held transmitter.

Fabric appearance:

- Due to the fabric bale supports, certain climatic conditions can cause pressure marks on the fabric (temperature, moisture). This does not limit the function/durability in any way.
- **We recommend the fabric quality Screen, as this creates an even fabric appearance as well as a taut fabric tension.**

Surface:

- Anodised finishes are not possible with the Lamaxa L50.

Attention: A GranTex with easyZIP guidance cannot be used with a Lamaxa L50 in the same field together with other optional extras.

Construction limit values

Configuration variants	Minimum order width	Maximum order width	Maximum order height	Minimum order height	Maximum order area
Fabric qualities + Box					
Screen fabric 4 % / 5 % + Size 110	3001 mm	6000 mm	3000 mm	600 mm	18 m ²
Soltis 92 + Size 110	3001 mm	6000 mm	3000 mm	600 mm	18 m ²

If the order width exceeds the available bale width, the fabric is used crosswise.

In this case, we recommend using all fabrics on a facade crosswise so that a uniform appearance is achieved on the whole building.

Dimension determination

Height GranTex with easyZIP guidance = headroom (length of pole - ground extension)

Width GranTex with easyZIP guidance = order width/length L50 - 222 mm

Measuring instructions, box without wall console

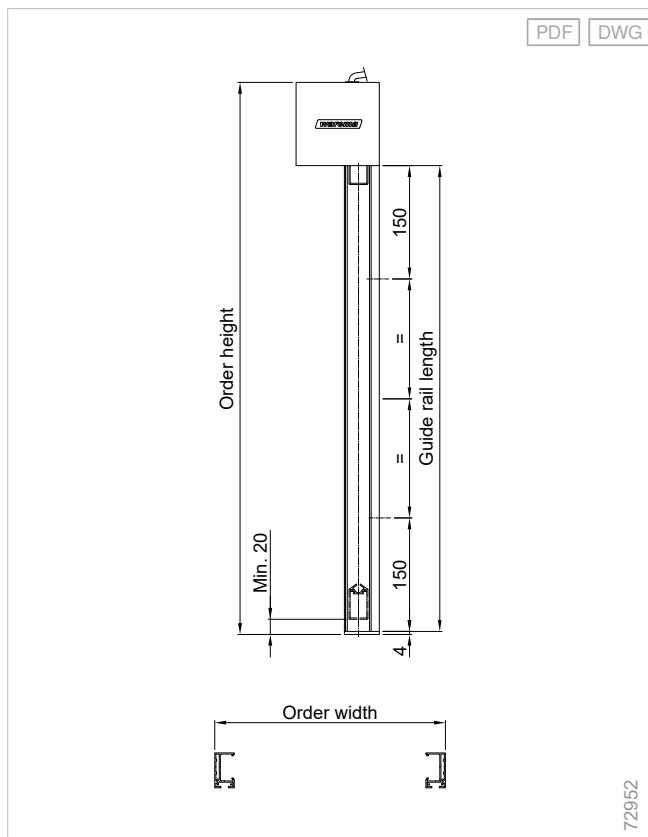

Weight assessment

Weight assessment for window awnings

Order height	Order width						
	3001 mm	3500 mm	4000 mm	4500 mm	5000 mm	5500 mm	6000 mm
600 mm	27 kg	30 kg	33 kg	36 kg	39 kg	42 kg	45 kg
1000 mm	30 kg	32 kg	35 kg	39 kg	42 kg	45 kg	48 kg
1500 mm	31 kg	34 kg	38 kg	41 kg	44 kg	47 kg	51 kg
2000 mm	33 kg	36 kg	40 kg	43 kg	46 kg	50 kg	53 kg
2500 mm	35 kg	38 kg	42 kg	45 kg	49 kg	52 kg	56 kg
3000 mm	37 kg	40 kg	44 kg	48 kg	51 kg	55 kg	59 kg

Detailed information is available on request.

Quantity determination

Number of fixing points

Guide rail length	Number
1000 mm	2
1001 - 1700 mm	3
1701 - 2400 mm	4
2401 - 3000 mm	5

The number of drilled holes is specified for WAREMA fixing materials. For customer-specific fixing materials, the size, distance and material to be fixed must be checked by the customer.

Box dimensions

Box size	Box shapes	Height H	Depth D
110	Rectangular	110 mm	110 mm

Box size 110, direct installation

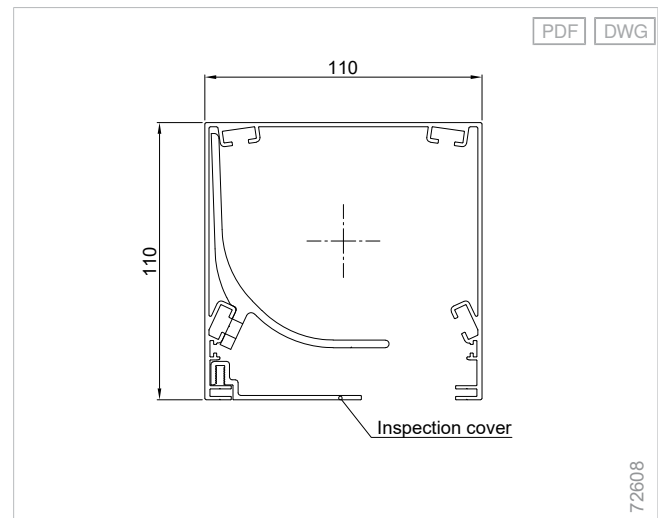

Viewing height of the end rail GranTex

Minimum viewing height from lower edge of box

Box size	End rail, rectangular
110	25 mm
110 with high inspection cover	0 mm

Guide rail selection

Guide rail selection according to the installation situation

Installation situation	Drilled hole 1 (reveal)
Right-rolling blind, deep guide rail, with direct screw connection	FS T-26x110-G

Reveal installation drilled hole 1, not watertight against driving rain.

The dimensions of the deep guide rail are identical to those of the pole and ensure a clean appearance.

Legend:

- FS = guide rail
- T = deep guide rail
- G = closed
- R = right-rolling blind

Details

Box support through screw connection - L50

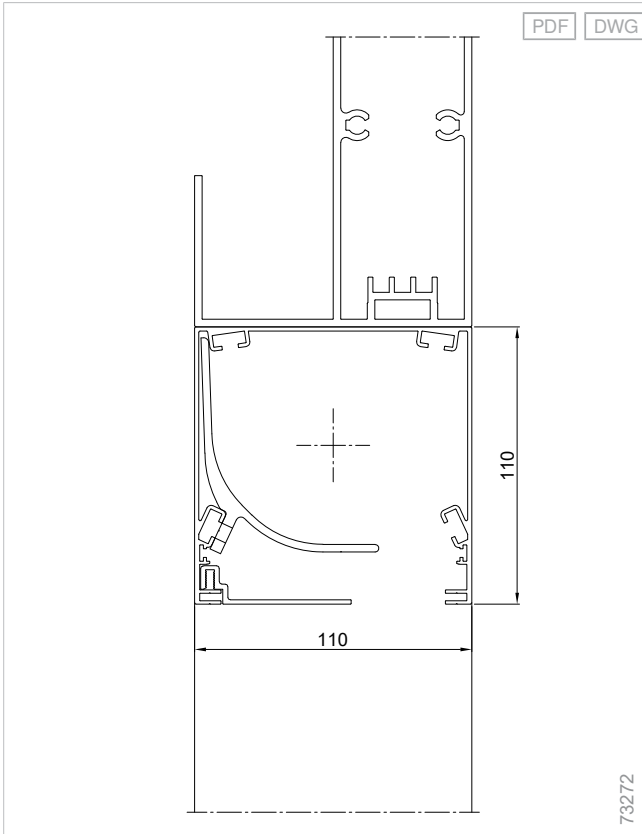

GranTex with easyZIP guidance - L50

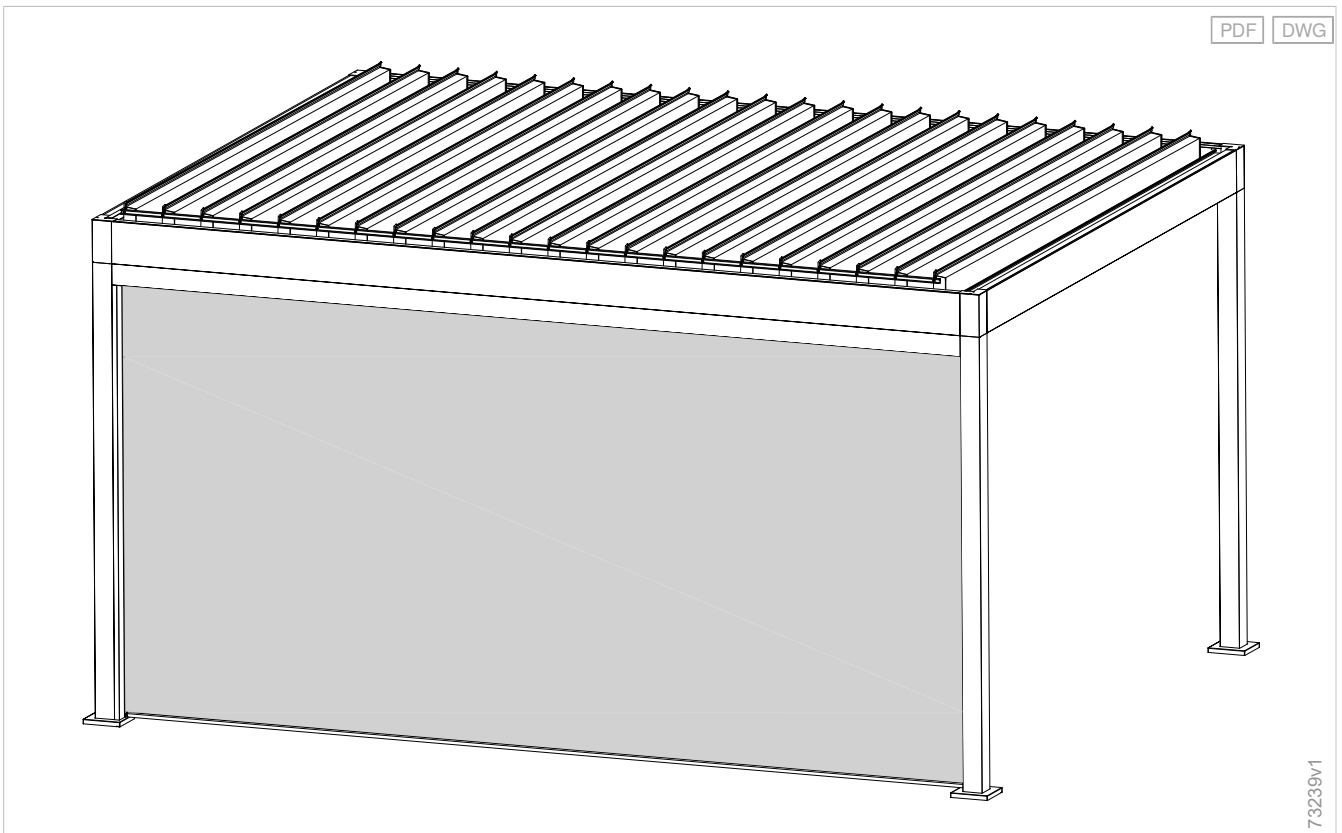

Planning

Slat roofs
Lamaxa

Glass roofs
Lamaxa

Fabric roofs
Lamaxa

Supplementary
accessories

Drive
variants

Standards

Additional product information

Cable exit

Standard cable exit: Rear, side or top

Cable exit sealing: With cable grommet

Motor line:

Motor, incl. 0.5 m motor line with plug-in connector (approx. 0.2 m from box end)

If GranTex with easyZIP guidance are installed at the front, the cable exit is provided from the drainage gutter. The cable is laid on the side where the mains connection to the house wall is located (connection side).

Cable exit for rectangular box shape

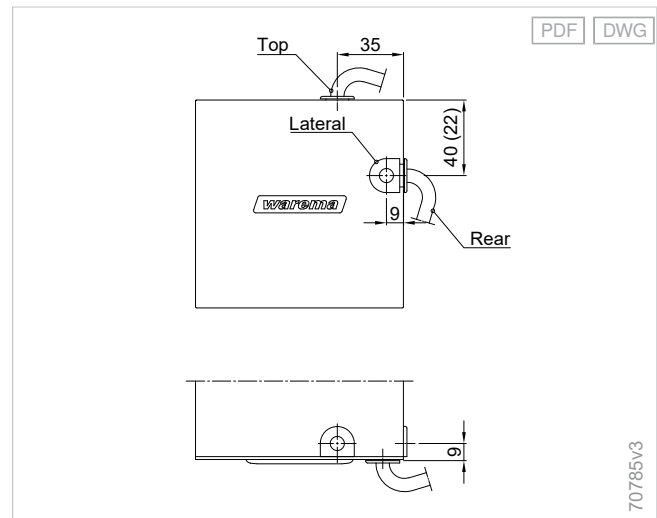

Note: the value in parentheses "22" applies exclusively to box size 90 in conjunction with a lateral cable exit, provided that this box size can be supplied in accordance with the product description.

Components

Guide rail T-26x110-G

Material	Aluminium, extruded
Surface	Powder-coated
Optional surface	Anodised
Width	26 mm
Depth	110 mm

- Depending on the installation situation, the depth of the guide rails varies from 110 mm to 130 mm (see table under additional product information).
- Plug-in connector accommodation: The accommodation of the plug-in connector within the guide rail is only possible with a left-rolling blind

Guide rail T-26x110-G

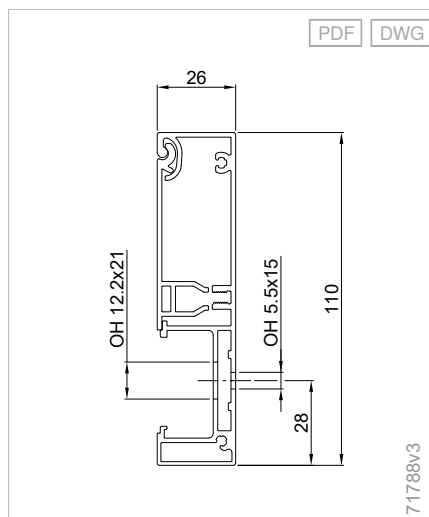

Guide rail T-26x110

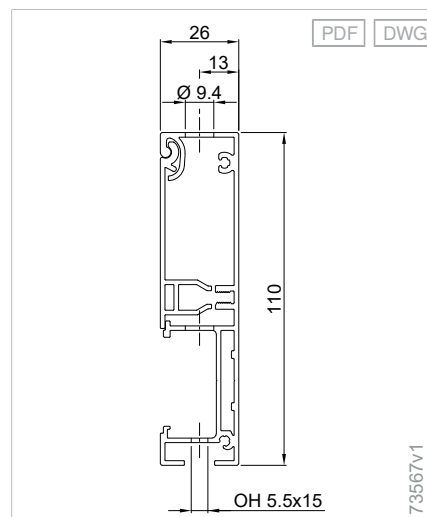



Conservatory awnings Climara, under glass

Conservatory awnings Climara W10

Seamless

No light gap with secudrive® technology: The fabric is attached to a spring steel strip and runs in a rail. This ensures there are no light gaps on the sides.

Slender

Light and airy appearance: Thanks to the flat and compact design, the awning has a particularly slender appearance.

Expanded

Optimal light with privacy: Optional lowerable valance roller blind protects you against low sun and improves your visual privacy.

Can be used for:

- Lamaxa L50 View

Construction limit values

Maximum order width	6500 mm
Maximum order length	6000 mm
Maximum order area	30 m ²

Order here

myWAREMA

🔗 *Art.-Nr. 2036169*

Order form

🔗 <https://docs.warema.com/fi/878105.pdf>

WAREMA tools

🔗 *Collection Assistant*

🔗 *Sun Shading Planner*

➕ *see "Navigating the document", Page 5*

Components

Climara W10 conservatory awning with round cover panel

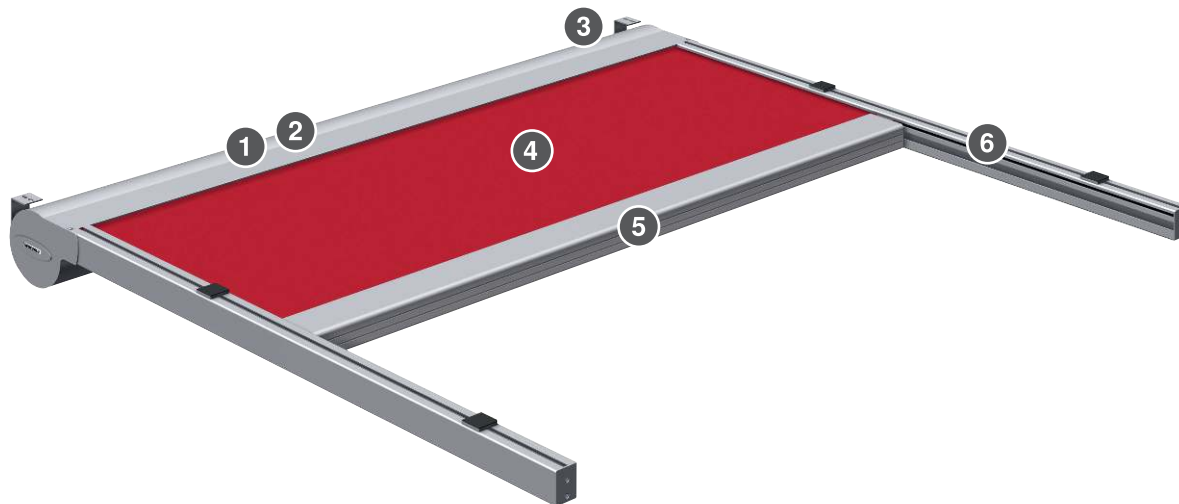

- 1 Cover panel
- 2 Shaft
- 3 Bracket

- 4 Awning fabric
- 5 Front rail
- 6 Guide rail

Climara W10 conservatory awning with rectangular cover panel

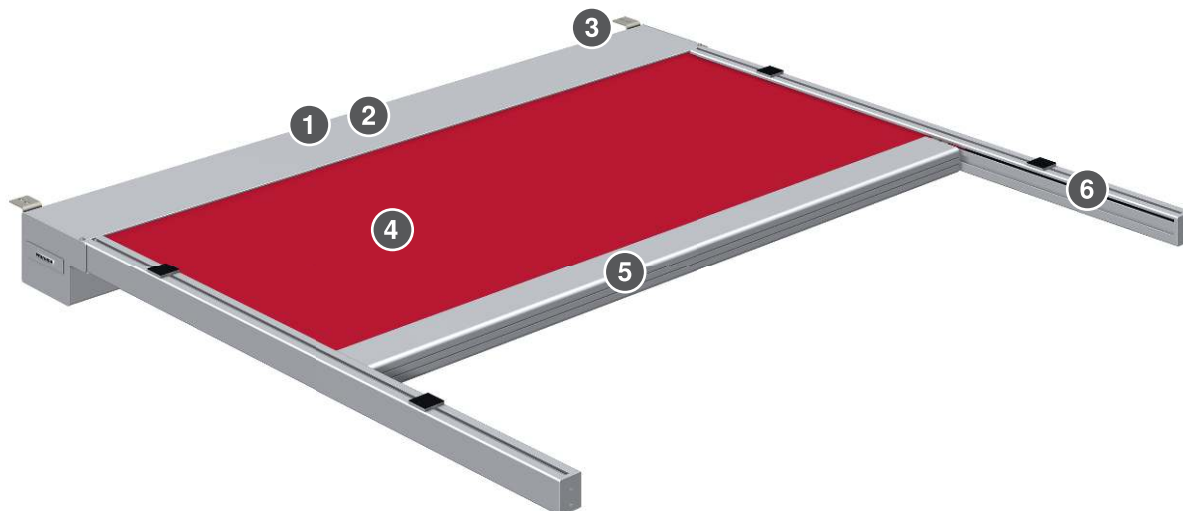

- 1 Cover panel
- 2 Shaft
- 3 Bracket

- 4 Awning fabric
- 5 Front rail
- 6 Guide rail

Planning

Slat roofs
Lamaxa

Glass roofs
Lamaxa

Fabric roofs
Lamaxa

Supplementary
accessories

Drive
variants

Standards

Construction limit values

Configuration variants	Minimum order width	Maximum order width	Minimum order length	Maximum order length	Maximum order area	Minimum inclination angle	Maximum inclination angle
Fabric qualities							
Acrylic fabric / Starlight Blue	650 mm	6500 mm	950 mm	6000 mm	30 m ²	0 °	45 °
All Weather acrylic / Twilight Pearl	650 mm	6500 mm	950 mm	6000 mm	28 m ²	0 °	45 °
Soltis 92 / Screen fabric 4 % / 5 %	650 mm	3500 mm	950 mm	4000 mm	14 m ²	0 °	45 °
Soltis B92	900 mm	2500 mm	1200 mm	4000 mm	10 m ²	0 °	0 °
Fabric qualities + Supplementary accessories							
Acrylic fabric / Starlight Blue + Valance roller blind	650 mm	5000 mm	950 mm	6000 mm	30 m ²	0 °	45 °
Acrylic fabric / Starlight Blue + VUNO model	650 mm	6500 mm	950 mm	6000 mm	24 m ²	0 °	45 °
All Weather acrylic / Twilight Pearl + Valance roller blind	650 mm	5000 mm	950 mm	6000 mm	28 m ²	0 °	45 °
All Weather acrylic / Twilight Pearl + VUNO model	650 mm	6500 mm	950 mm	6000 mm	24 m ²	0 °	45 °
Soltis 92 / Screen fabric 4 % / 5 % + Valance roller blind	650 mm	3500 mm	950 mm	4000 mm	14 m ²	0 °	45 °
Soltis 92 / Screen fabric 4 % / 5 % + VUNO model	650 mm	3500 mm	950 mm	4000 mm	14 m ²	0 °	45 °

Minimum order width:

- From an order length of 5001 mm, a minimum order width of 812 mm is required.
- For versions with SDO switch, a minimum order width of 900 mm is required.

Series-mounted units:

- Generally, only individual units are possible, i.e. no unit coupling!
- Each awning section requires two single guide rails.
- Two guide rails can be mounted on one bracket.
- In the case of a series-mounted unit, an expansion joint of 20 mm is required after 13000 mm!

VUNO: Valance roller blinds are not possible for a "from bottom to top" direction of movement.



Conservatory awnings Climara, on glass

Conservatory awnings Climara W20

Durable

Wind-stable construction: The fabric is attached to a spring steel strip that runs tautly in the guide rail - a reinforcement profile additionally tensions the fabric.

Seamless

No light gap with secudrive® technology: The fabric runs taut in the rail so that no light enters at the sides.

Automated

More convenience with integrated sensors: A sensor measures wind, brightness and precipitation so that the awning retracts or extends depending on the weather, all by itself.

Can be used for:

- Lamaxa L50 View

Construction limit values

Maximum order width	6500 mm
Maximum order length	6000 mm
Maximum order area	30 m ²

Order here

myWAREMA

[Art.-Nr. 2036171](#)

Order form

<https://docs.warema.com/fi/2008884.pdf>

WAREMA tools

[Collection Assistant](#)

[Sun Shading Planner](#)

[+ see "Navigating the document", Page 5](#)

Components

Climara W20 conservatory awning with round cover panel

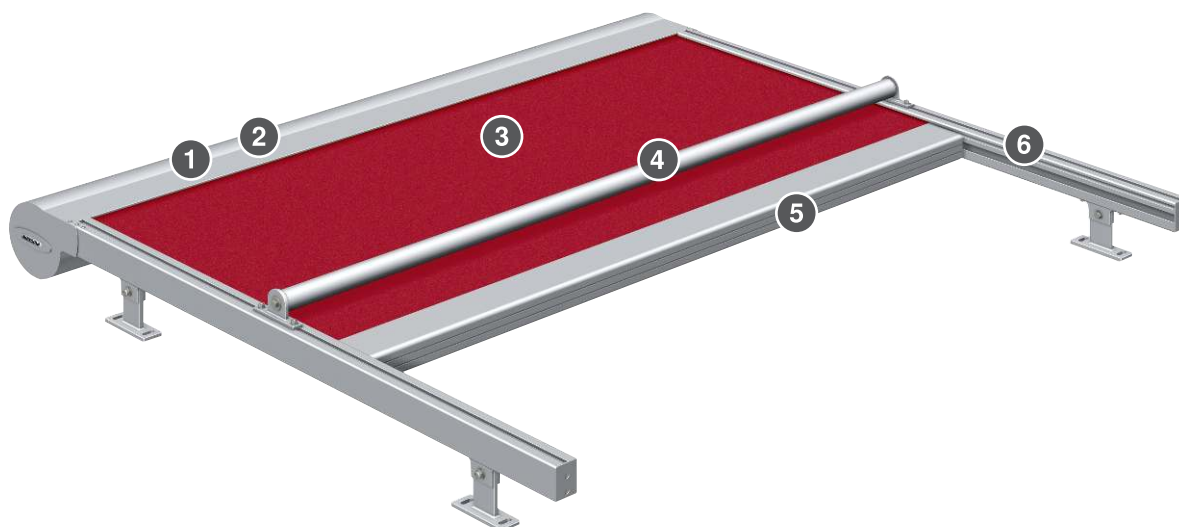

- 1 Cover panel
- 2 Shaft
- 3 Awning fabric

- 4 Reinforcement profile
- 5 Front rail
- 6 Guide rail

Climara W20 conservatory awning with rectangular cover panel



- 1 Cover panel
- 2 Shaft
- 3 Awning fabric

- 4 Reinforcement profile
- 5 Front rail
- 6 Guide rail

Planning

Slat roofs
Lamaxa

Glass roofs
Lamaxa

Fabric roofs
Lamaxa

Supplementary
accessories

Drive
variants

Standards

Construction limit values

Configuration variants	Minimum order width	Maximum order width	Minimum order length	Maximum order length	Maximum order area	Minimum inclination angle	Maximum inclination angle
Fabric qualities							
Acrylic fabric / Starlight Blue	650 mm	6500 mm	950 mm	6000 mm	30 m ²	0 °	45 °
All Weather acrylic / Twilight Pearl	650 mm	6500 mm	950 mm	6000 mm	28 m ²	0 °	45 °
Soltis 92 / Screen fabric 4 % / 5 %	650 mm	3500 mm	950 mm	4000 mm	14 m ²	0 °	45 °
Fabric qualities + Supplementary accessories							
Acrylic fabric / Starlight Blue + Drainage cutouts	650 mm	6500 mm	950 mm	6000 mm	30 m ²	3 °	16 °
Acrylic fabric / Starlight Blue + VUNO model	650 mm	6500 mm	950 mm	6000 mm	24 m ²	0 °	45 °
All Weather acrylic / Twilight Pearl + Drainage cutouts	650 mm	6500 mm	950 mm	6000 mm	28 m ²	3 °	16 °
All Weather acrylic / Twilight Pearl + VUNO model	650 mm	6500 mm	950 mm	6000 mm	24 m ²	0 °	45 °
Soltis 92 / Screen fabric 4 % / 5 % + VUNO model	650 mm	3500 mm	950 mm	4000 mm	14 m ²	0 °	45 °

Minimum order width:

- From an order length of 5001 mm, a minimum order width of 812 mm is required.
- For versions with SDO switch, a minimum order width of 900 mm is required.

Series-mounted units:

- Generally, only individual units are possible, i.e. no unit coupling!
- Each awning section requires two single guide rails.
- Two guide rails can be mounted on one bracket.
- In the case of a series-mounted unit, an expansion joint of 20 mm is required after 13000 mm!

Reinforcement profile, round:

- For order lengths of 2501 mm and greater, a Ø 40 mm reinforcement profile is used.
- For order widths from 3501 mm, a Ø 60 mm profile is used.

Reinforcement profile, rectangular:

- From order lengths of 2501 mm, a rectangular reinforcement profile (50x50 mm) is used.



Supplementary accessories

Sash frames

Multifunctional

The sash frames not only provide protection from the sun, but also from unwanted glances and the effects of the weather.

Enhancing

The sash frames look particularly elegant and stylishly enhance the slat roof.

Comfortable

Depending on your personal taste: Whether glass, wood or aluminium, the slat roof can be made as individual as required.



Can be used for:

- Lamaxa L70
- Lamaxa L60
- Lamaxa L50

Product characteristics

- Depending on design, the sash frames ensure an optimum sun shading system, and wind and weather protection.
- They create a special ambiance on the slat roof.

Glass sliding system SL20e - L50/L60/L70

Components

Running rail

Top running rail, 2-track - SL20e

Material	Aluminium
Surface	Powder-coated
Width	50 mm
Height	48.5 mm

Top running rail, 3-track - SL20e

Material	Aluminium
Surface	Powder-coated
Width	74 mm
Height	48.5 mm

Bottom running rail, 2-track - SL20e

Material	Aluminium
Surface	Anodised natural colour
Width	50 mm
Height	41 mm

Bottom running rail, 3-track - SL20e

Material	Aluminium
Surface	Anodised natural colour
Width	74 mm
Height	41 mm

Running rail, optional

Bottom running rail, flat, 2-track - SL20e

Material	Aluminium
Surface	Anodised natural colour
Material, notes	with drainage
Width	50 mm
Height	22.5 mm

Bottom running rail, flat, 3-track - SL20e

Material	Aluminium
Surface	Anodised natural colour
Material, notes	with drainage
Width	74 mm
Height	22.5 mm

Filling material

Glazing ESG 10 mm

At an installation height of 4 m and above, a hot-soak-test approved single pane safety glass should be used (on request at a surcharge).

Interlock, optional

Stop bolt

The stop bolt in the lower wing profile ensures that the wings cannot be moved when extended. One stop bolt is used for each wing joint.

Drive variants

Manual operation

- Manual operation - sliding glass elements SL20e

Handle

- Handle shell

+ see "Drive variants", Page 201

Colours

- WAREMA Colour World

+ see "Colours and finishes", Page 10

Product characteristics

Attachment:

- Installation between the poles of the slat roof
- One unit per field is possible
- The poles must be designed with floor recess, since the base plates (incl. fixing material) otherwise protrude into the installation space of the SL20e.
- The lower running rail must be installed horizontally, any slopes in the substructure must be compensated for on-site.

Notes

Notes concerning the order

We recommend ordering the SL20e glass sliding system only after the slat roof is installed. Measurement inaccuracies may mean that the glass sliding systems do not fit.

Notes on product configuration

A suitable substructure is required for fixing the bottom running rail.

Glazing including handle must not be larger than 76 mm. Here it must be noted that a load transfer via the crossbeam is not possible.

Notes on operation

In case of snow and wind speeds of > 13 m/s, the glass sliding system SL20e has to be moved into the lateral position.

Power socket in combination with sash frame: A power socket cannot be installed on the same side of the pole as the sash frame.

Construction limit values

Configuration variants	Minimum order width	Maximum order width	Minimum order height	Maximum order height
Components				
3-track, three-wing	2000 mm	3200 mm	1300 mm	2600 mm
2-track, four-wing	3201 mm	4200 mm	1300 mm	2600 mm
3-track, six-wing	4201 mm	6000 mm	1300 mm	2600 mm

Order width:

- The width of the SL20e corresponds to the clearance dimension of the Lamaxa.
- Width SL20e L60/L70 = order length/width Lamaxa - 2x169 mm.
- Width SL20e L50 = order length/width Lamaxa - 2x110 mm.
- The width of the individual wings is defined based on the order width for SL20e and the number of wings.
- When closed, the glass wings overlap each other by 40 mm.

Order height:

The order height of SL20e corresponds to the headroom of the lower Lamaxa pole.

Dimension determination

Configuration view:

L60/L70, sash frames with slope

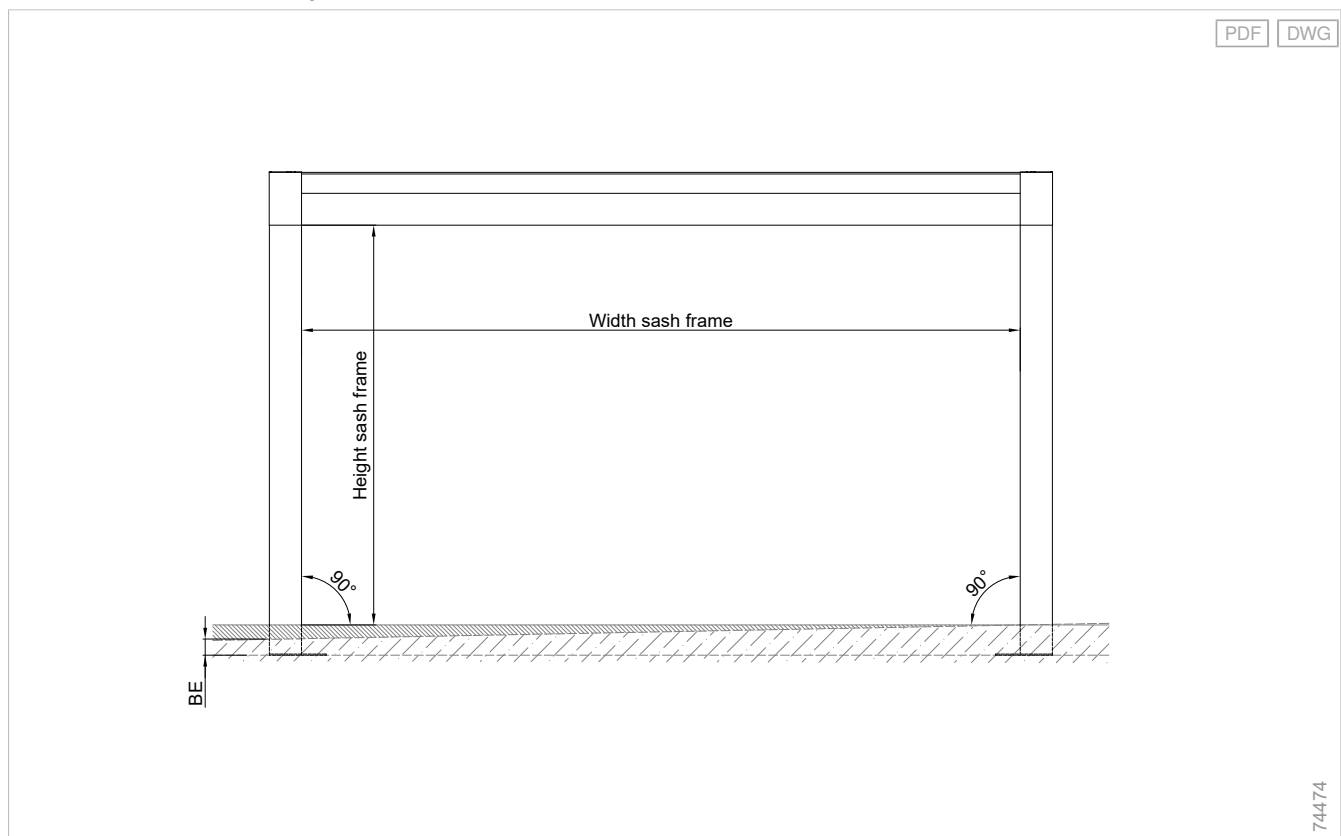

The lower running rail must be installed horizontally, any slopes in the substructure must be compensated for on-site. The poles must be designed with ground extension (BE), since the base plates (incl. fixing material) otherwise protrude into the installation space of the sash frame.

L60/L70, SL20e, 2-track, four-wing, closed

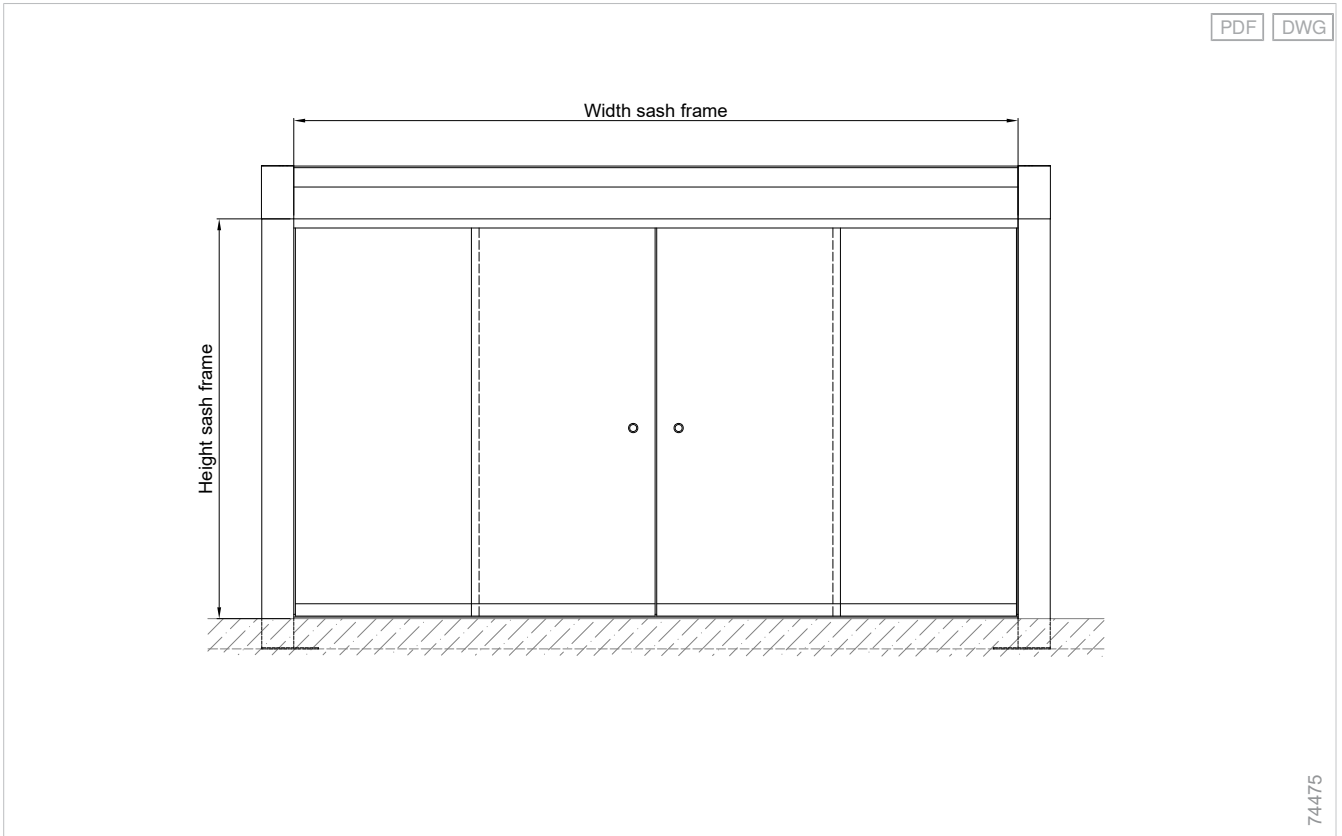

When closed, the glass wings overlap each other by 40 mm.

Number of wings and arrangement - SL20e

PDF DWG

3-track, 3 wings
Stack on the left
(Type 3L)

Outside

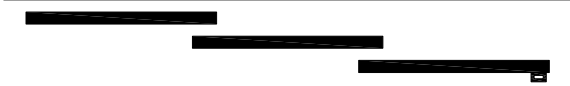

3-track, 3 wings
Stack on the right
(Type 3R)

Outside

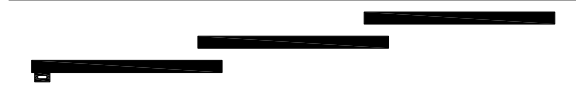

2-track, 4 wings
(Type 2L + Type 2R)

Outside



3-track, 6 wings
(Type 3L + Type 3R)

Outside



72556v1

Details

L60/L70, SL20e, 3-track, flat running rail

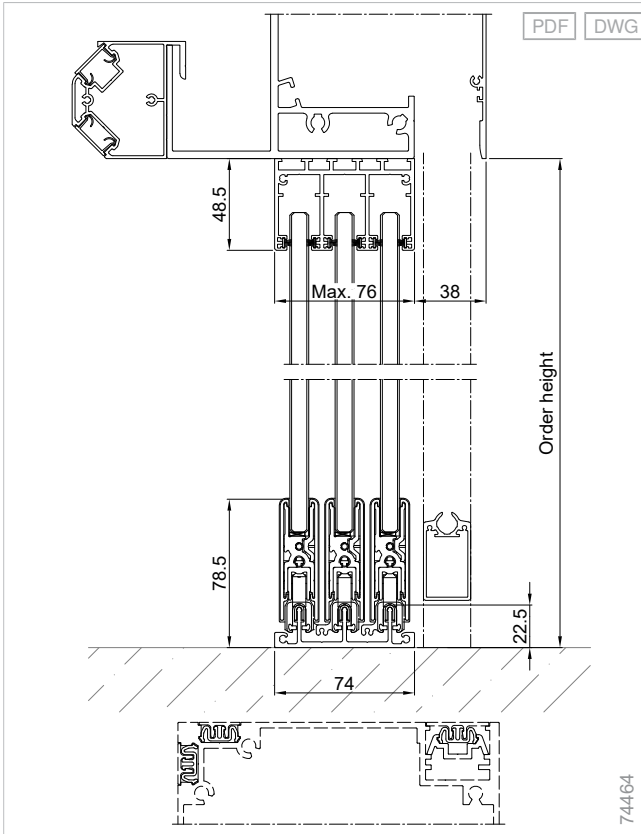

L60/L70, SL20e, 2-track, flat running rail

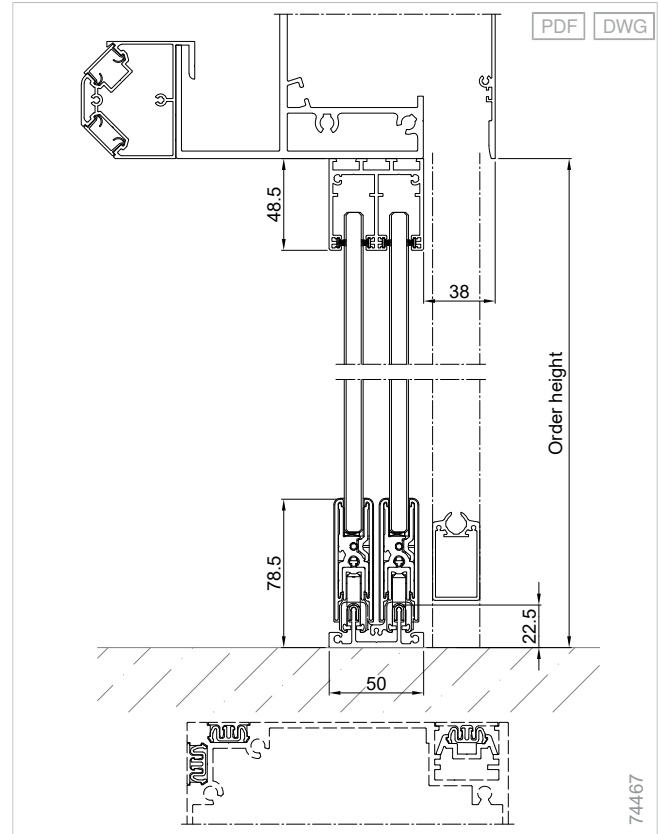

L60/L70, SL20e, 3-track, running rail

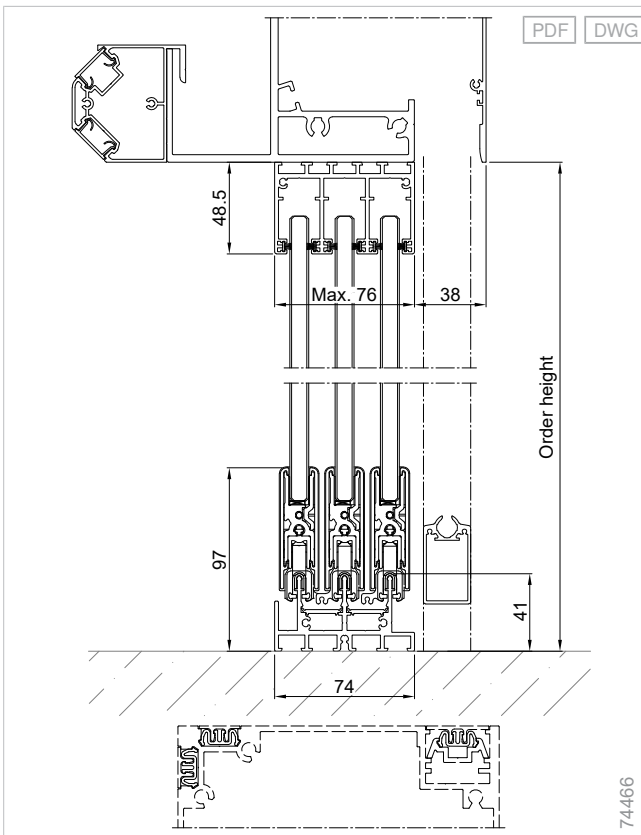

L60/L70, SL20e, 2-track, running rail

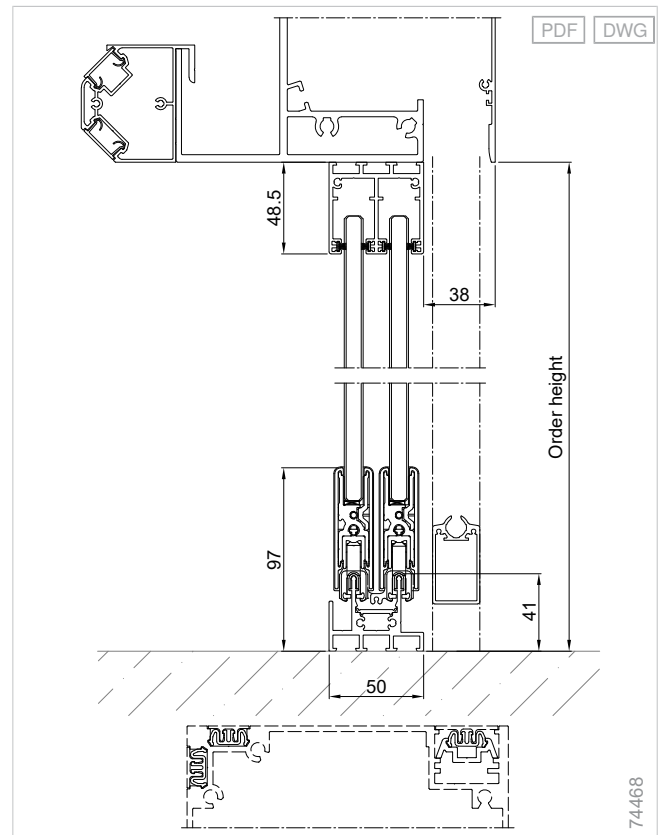

Planning

Slat roofs
Lamaxa

Glass roofs
Lamaxa

Fabric roofs
Lamaxa

Supplementary
accessories

Drive
variants

Standards

Flat running rail, 2-track, SL20e - L50

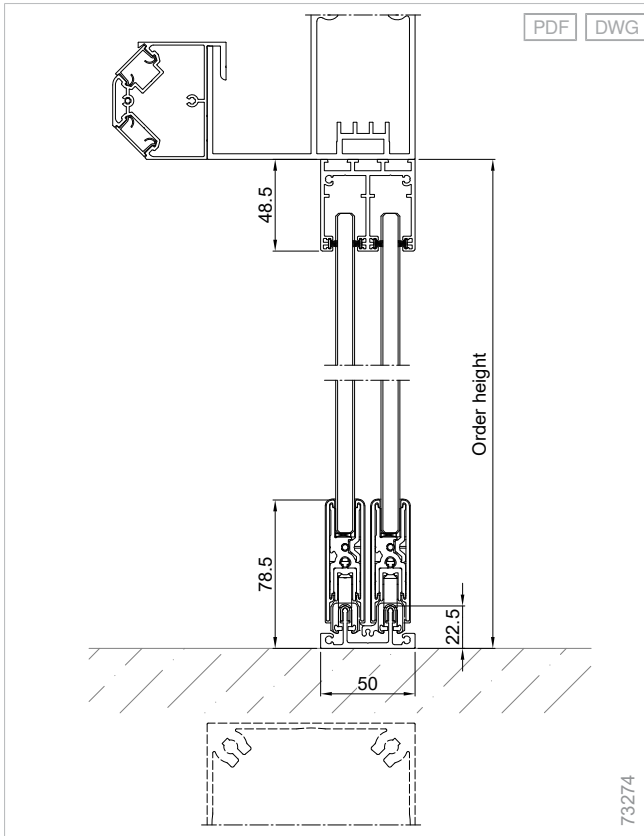

Flat running rail, 3-track, SL20e - L50 View edge rafter

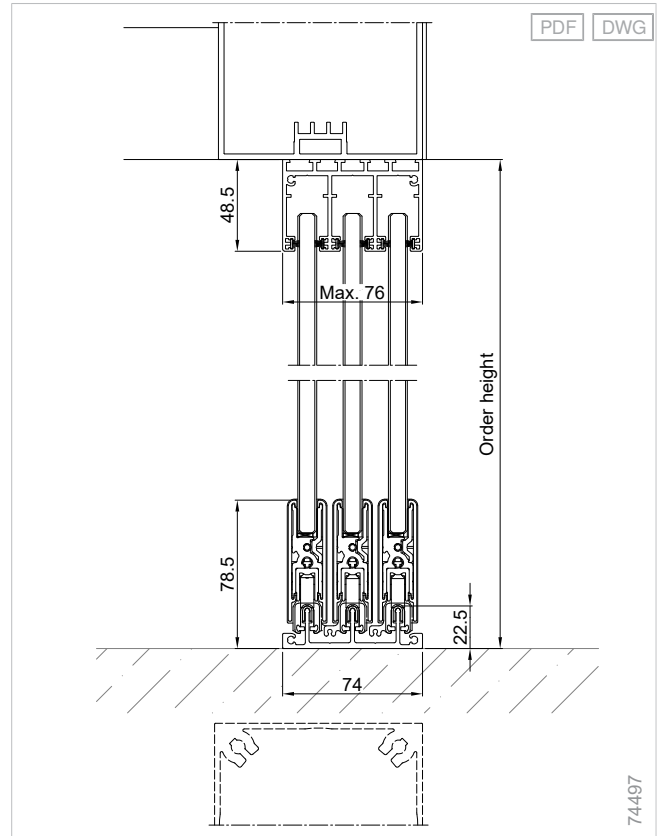

Flat running rail, 3-track, SL20e - L50

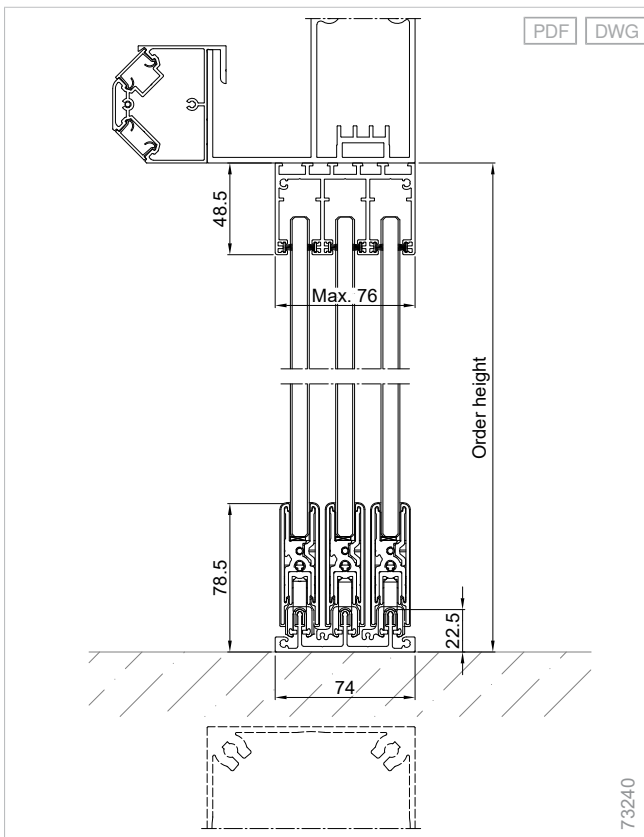

Flat running rail, 3-track, SL20e - L50 View crossbeam

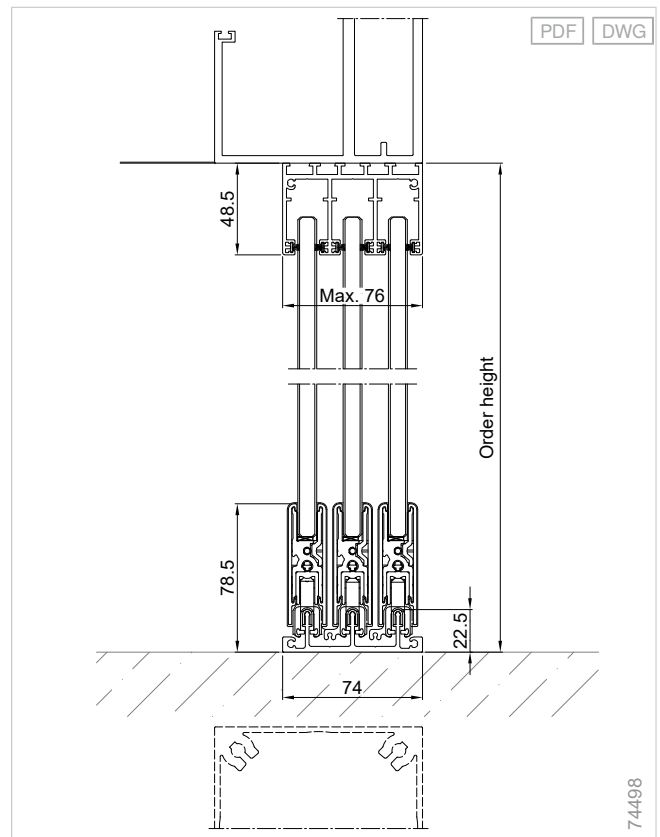

Sliding shutters L50/L60/L70

Components

Running rail

Upper running rail for sliding shutter

Material	Aluminium
Surface	Anodised
Width	30 mm
Height	37 mm

Upper running rail facing for sliding shutter

Material	Aluminium
Surface	Coated
Profile	Angle-shaped profile
Width	20 mm
Height	80 mm

Base support, 1-track

Material	Aluminium
Surface	Coated
Width	70 mm
Height	10 mm

Base support, 2-track

Material	Aluminium
Surface	Coated
Width	110 mm
Height	10 mm

Base support, 3-track

Material	Aluminium
Surface	Coated
Width	150 mm
Height	10 mm

Lower running rail for aluminium sliding shutter

Material	Aluminium
Surface	Anodised
Profile	Angle-shaped profile
Width	40 mm
Height	30 mm

Filling material

Aluminium slats

Material	Aluminium
Surface	Powder-coated
Material, notes	Weight: 11.7 kg/m ²
Width	60 mm
Height	15 mm

Wooden slats

Material	Wood
Material, notes	Weight: 13.8 kg/m ² <ul style="list-style-type: none"> - The wood used is larch. - Untreated larch does not require treatment and is suitable for natural silver grey colouring. - The sanded wood surface is prone to natural wear. - Wood is a natural product. The colours and surface structures of one type of wood can naturally differ in each cut. - The wood may contain small firmly inter-grown branches (5 - 8 mm). - Warping, cracking and resin leakage may occur with a natural product and do not impair its function.

Width	60 mm
Height	15 mm

Frame

Frame

Material	Aluminium, extruded
Surface	Powder-coated
Height	40 mm
Depth	32 mm

Incl. drive, suspension bracket and rail buffer.

Colours

- WAREMA Colour World

+ see "Colours and finishes", Page 10

Product characteristics

Attachment:

- Sliding shutter set (designed for the field size) or as individual sliding shutters.
- Installation between the poles of the slat roof.
- The poles must be designed with a floor recess, since the base plates (incl. fixing material) otherwise protrude into the installation space of the sliding shutters.
- The lower running rail must be installed horizontally, any slopes in the substructure must be compensated for on-site.
- Adapter plate for attaching several lower running rails (upon request).

Notes

Notes concerning the order

We recommend ordering sliding shutters only after the Lamaxa is installed. Measurement inaccuracies may mean that the sliding shutters do not fit.

Notes on product configuration

A suitable substructure is required for fixing the bottom running rail.

Notes on operation

In case of snow and wind speeds of > 13 m/ s, the sliding shutters have to be moved into the lateral position (rail buffer).

Power socket in combination with sash frame: A power socket cannot be installed on the same side of the pole as the sash frame.

Construction limit values

Configuration variants	Minimum order width	Maximum order width	Minimum order height	Maximum order height
Components				
3-track, three-wing	2000 mm	3200 mm	1000 mm	2800 mm
2-track, four-wing	2300 mm	4300 mm	1000 mm	2800 mm
3-track, six-wing	4301 mm	5900 mm	1000 mm	2800 mm
Individual	2000 mm	5900 mm	1000 mm	2800 mm
Wing width	600 mm	1100 mm		

The sliding shutters are available to order both as a set (see rows 1 - 3 of the table) as well as individually (see rows 4 - 5 of the table).

Available models:

- **It is not possible to integrate easyZIP into 3-track product variants.**
- **The LED-lighting in the poles of the L60/L70 2- and 3-track models is impaired.**
- **Only 1- or 2-track sliding shutter models can be used on a Lamaxa L50.**

Order width:

- The width of the sliding shutters corresponds to clearance dimension of the Lamaxa.
- Width of L60/L70 sliding shutters= order length/width of Lamaxa - 2x169 mm.
- Width of L50 sliding shutters= order length/width of Lamaxa - 2x110 mm.
- Sliding shutter set: the width of the individual wings (wing width) is defined based on the width of the sliding shutter and the number of wings. When closed, the wings overlap each other by 40 mm.
- Individual sliding shutters: the width of each individual wing (wing width) can be specified.
- The facing and upper/lower running rails correspond to the width of the sliding shutters.

Order height:

- The order height of the sliding shutters corresponds to the headroom of the lower Lamaxa pole.

Dimension determination

L60/L70, sash frames with slope

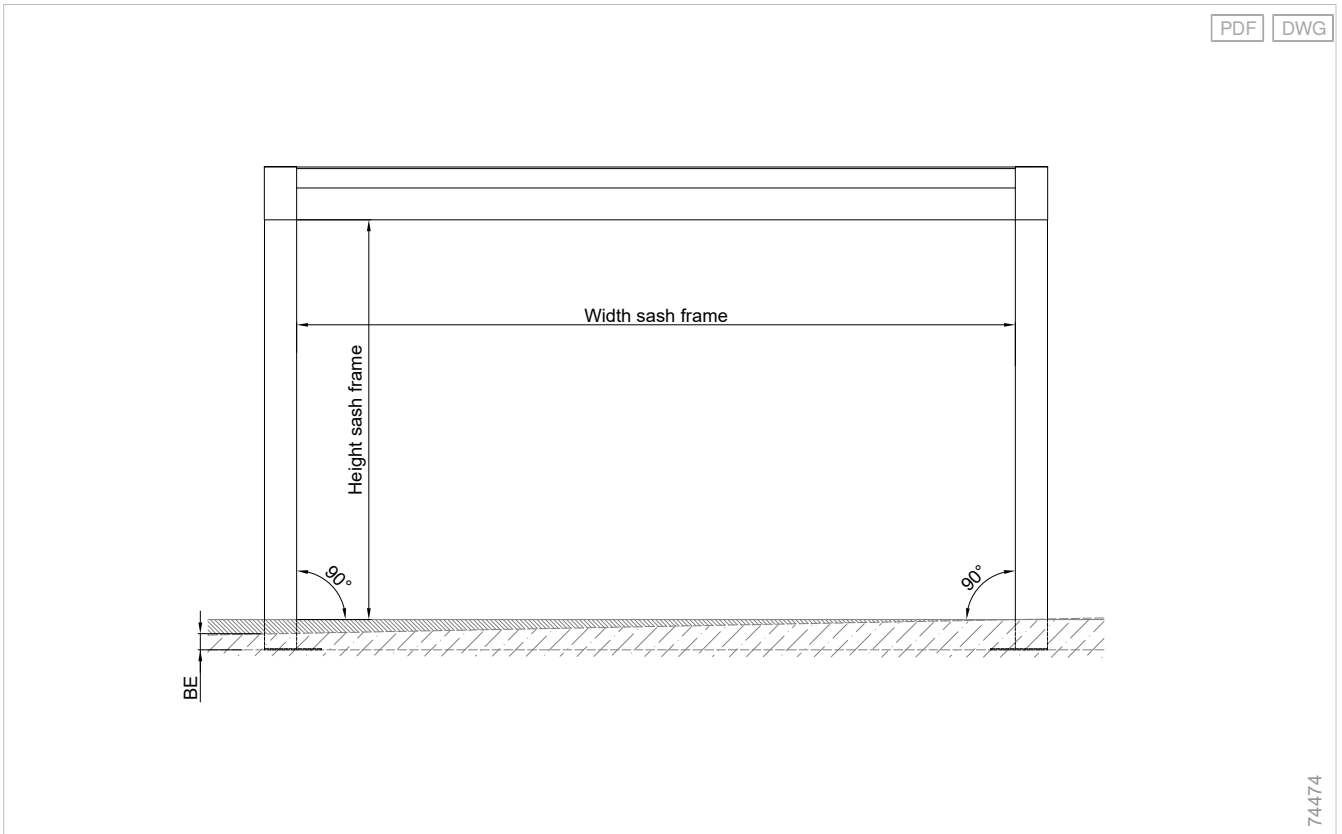

The lower running rail must be installed horizontally, any slopes in the substructure must be compensated for on-site. The poles must be designed with ground extension (BE), since the base plates (incl. fixing material) otherwise protrude into the installation space of the sash frame.

L60/L70, sliding shutter set

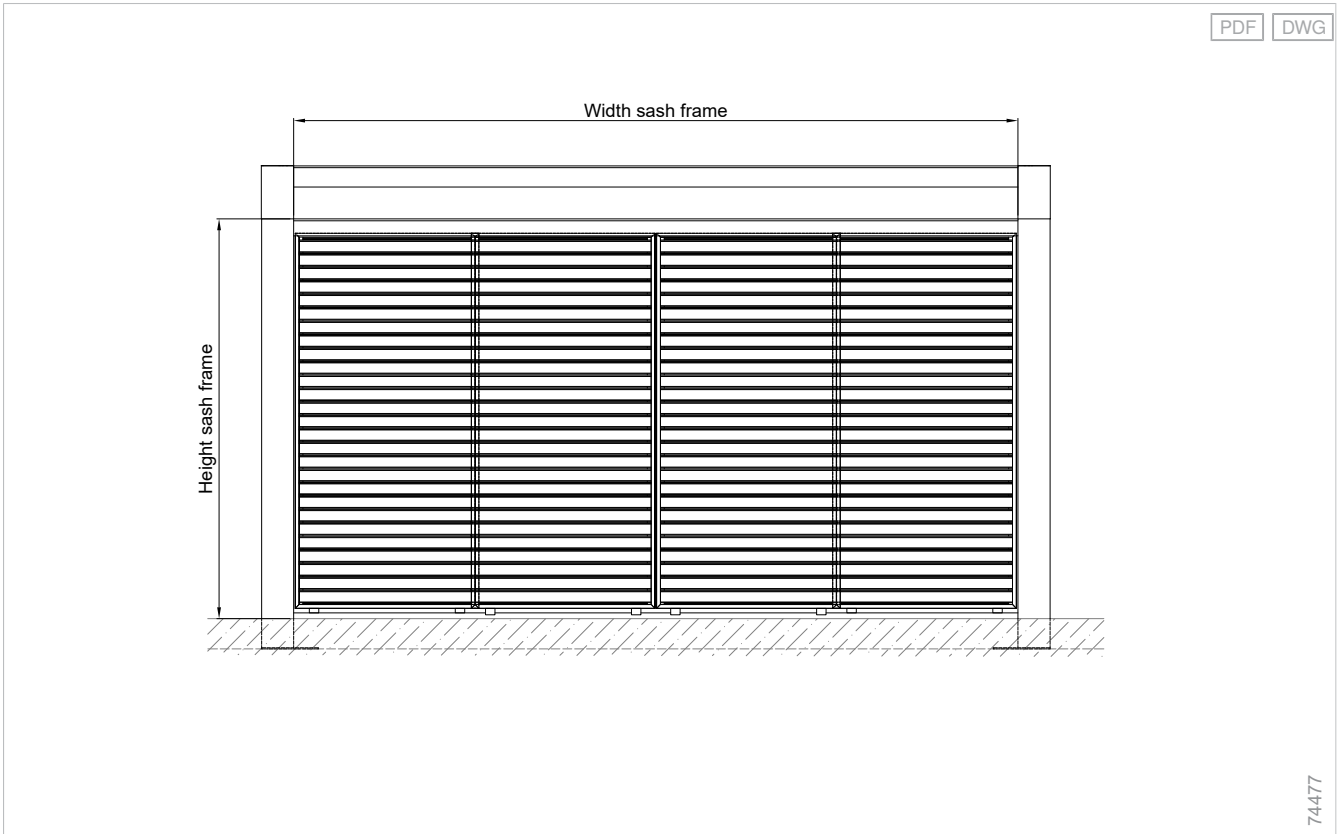

When closed, the wings overlap each other by 40 mm.

Single wing, sliding shutter - L60/L70

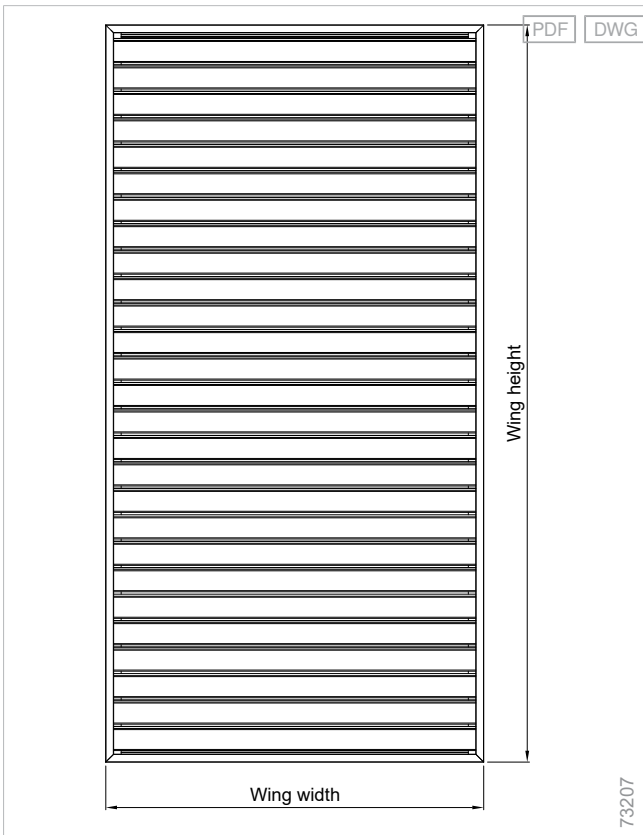

Number of wings and arrangement - sliding shutter set

PDF DWG

Set 3-track, 3 wings

Outside



Set 3-track, 3 wings

Outside



Set 2-track, 4 wings

Outside



Set 3-track, 6 wings

Outside

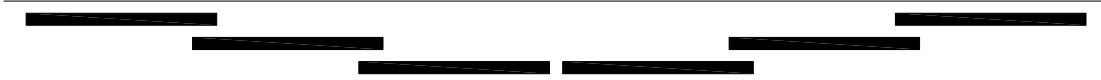

73701

Planning

Slat roofs
Lamaxa

Glass roofs
Lamaxa

Fabric roofs
Lamaxa

Supplementary
accessories

Drive
variants

Standards

Details

L60/L70, sliding shutters, 1-track

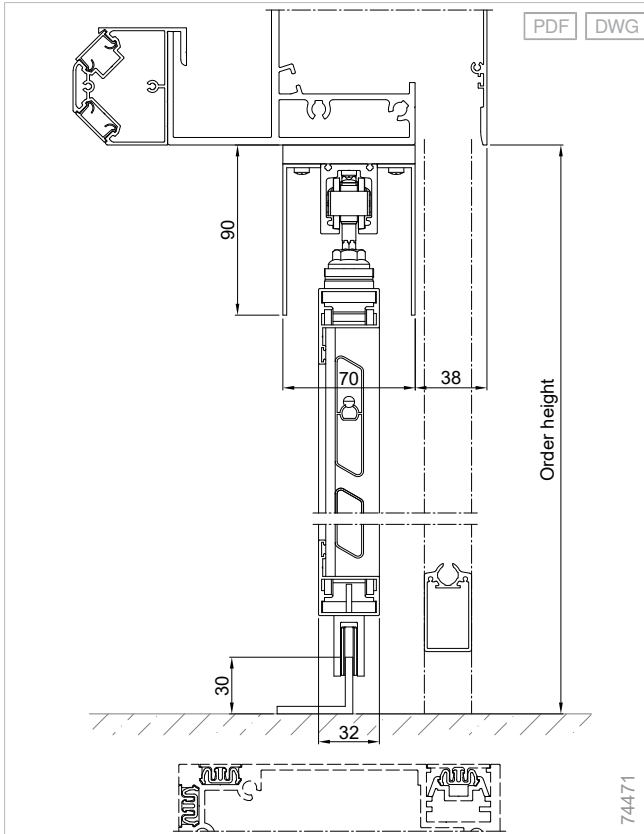

L60/L70, sliding shutters, 3-track

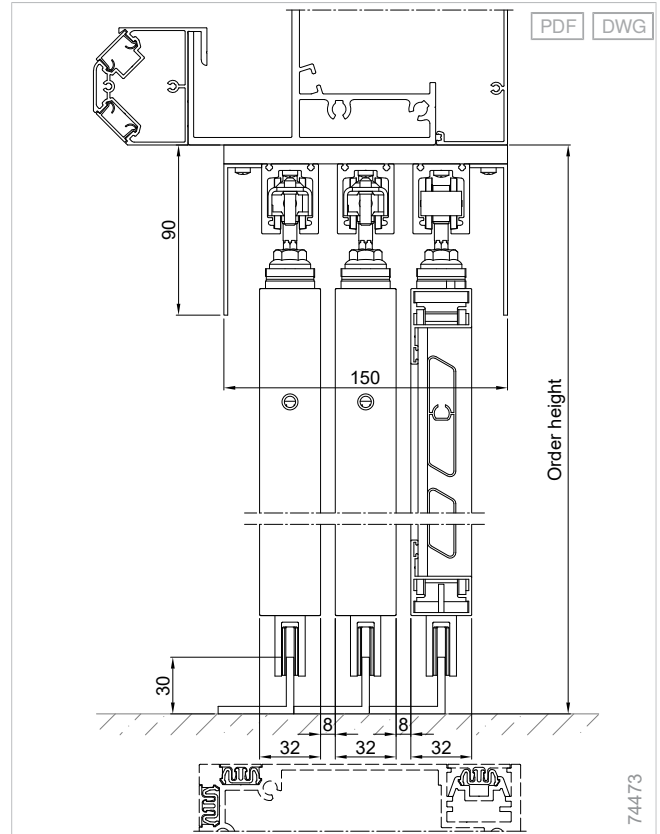

L60/L70, sliding shutters, 2-track

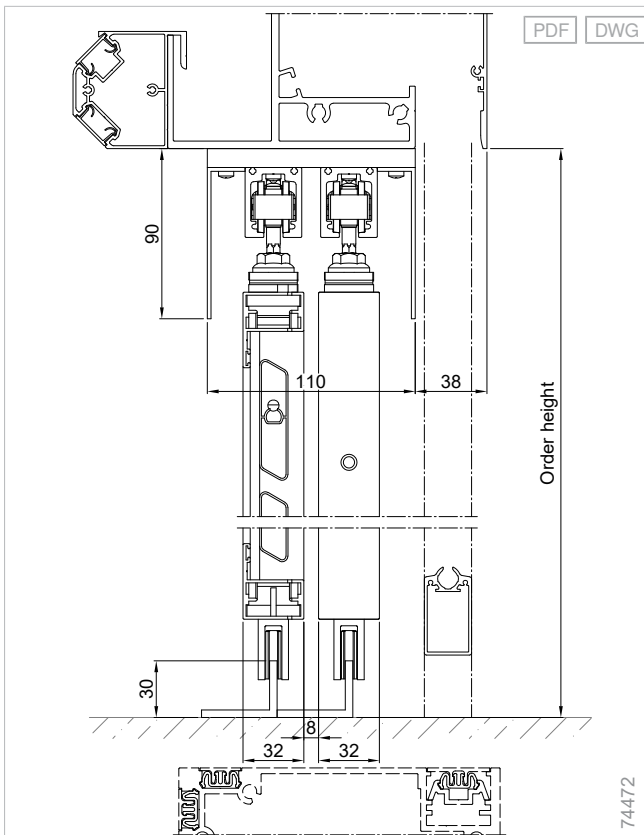

Running rail, 1-track, sliding shutters - L50

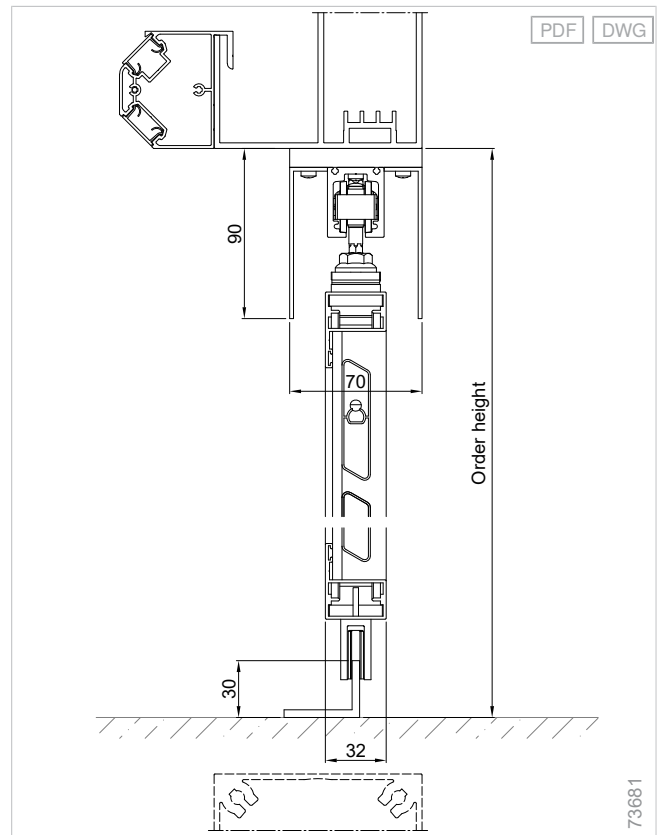

Running rail, 2-track, sliding shutters - L50

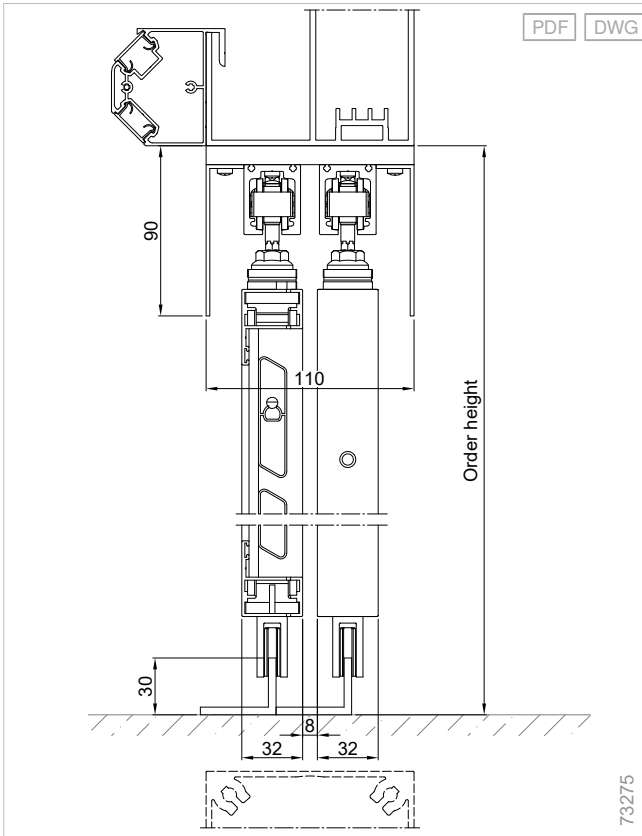

Planning

Slat roofs
Lamaxa

Glass roofs
Lamaxa

Fabric roofs
Lamaxa

Supplementary
accessories

Drive
variants

Standards



Supplementary accessories

Additional pole

Expanding

The additional pole creates extra sections so a throughhole can be realised, for example.

Combinable

Lateral shading with easyZIP guidance can be installed in or on the pole.

Illuminating

For an individual lighting atmosphere in the evenings: The dimmable LED strips can be integrated in or attached on the additional pole, depending on the type.

Can be used for:

- Lamaxa L70
- Lamaxa L60
- Lamaxa L50/L50 Tex



Product characteristics

- Creates a clear throughhole
- Vertical shading of one of the two fields using awnings with easyZIP guidance

Additional pole - L60/L70

Components

Pole

Pole - L60/L70

Material	Aluminium, extruded
Surface	Powder-coated
Width	170 mm
Height	170 mm

Installation options:

Ground installation with frost-proof, on-site foundation.

The grout for filling the clearance is not included in the scope of delivery when threaded rods are used.

Floor recess and separation cut:

For a floor recess, we recommend the use of a separation cut in the inspection parts to allow for inspection without dismantling the floor. If the floor recess does not have a separation cut, the easyZIP guidance inlays and the integrated LED strips reach the bottom edge of the pole profile.

Base plate

Base plate - corner installation L60/L70

Material	Galvanised steel
Surface	Plain
Optional surface	Powder-coated
Width	300 mm
Height	300 mm

Notes

Integrated awnings with easyZIP guidance in combination with additional pole:

- Maximum 6 units per slat roof
- If only one field is equipped with an easyZIP awning, a gap in the inspection cover will be visible from the free field below.

Integrated lighting in combination with additional pole:

- Attached in pairs per field
- Maximum 6 fields per slat roof
- Maximum total length of the LED strips for all fields of 29000 mm

Positioning:

- An additional pole can be positioned for each field.
- For additional pole installation and inspection access, a minimum distance of 300 mm is required between the additional pole and the facade.
- Corner base plate a or b can be selected.
- Downward and outward drainage possible.
- The additional pole has a minimum offset dimension of 250 mm.

Mounting examples

L60/L70, additional pole

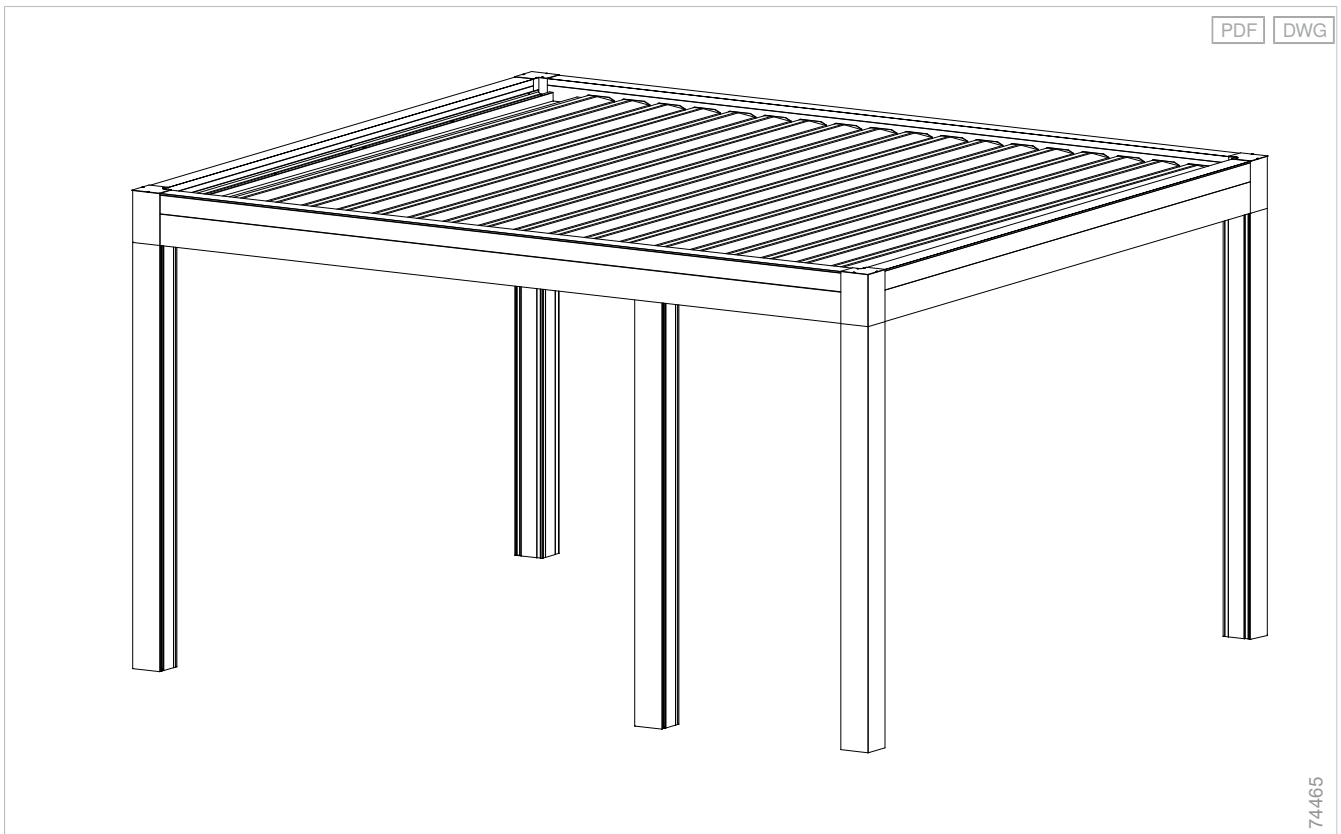

L60/L70, corner base plate a, additional pole

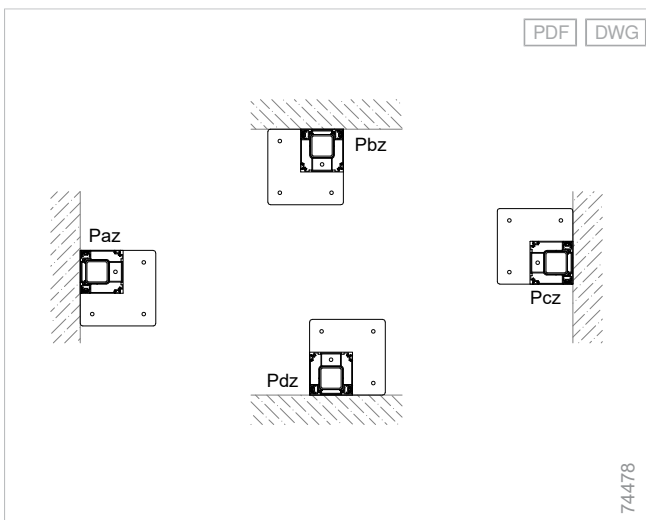

L60/L70, corner base plate b, additional pole

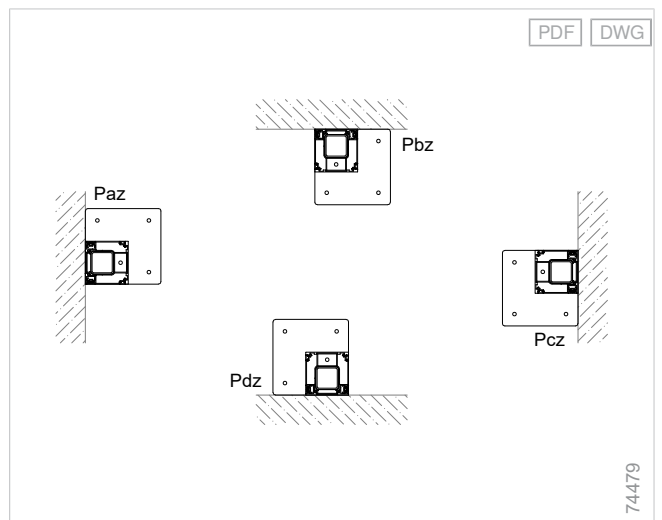

Top view of fields and poles - L50/L50 Tex/L60/L70

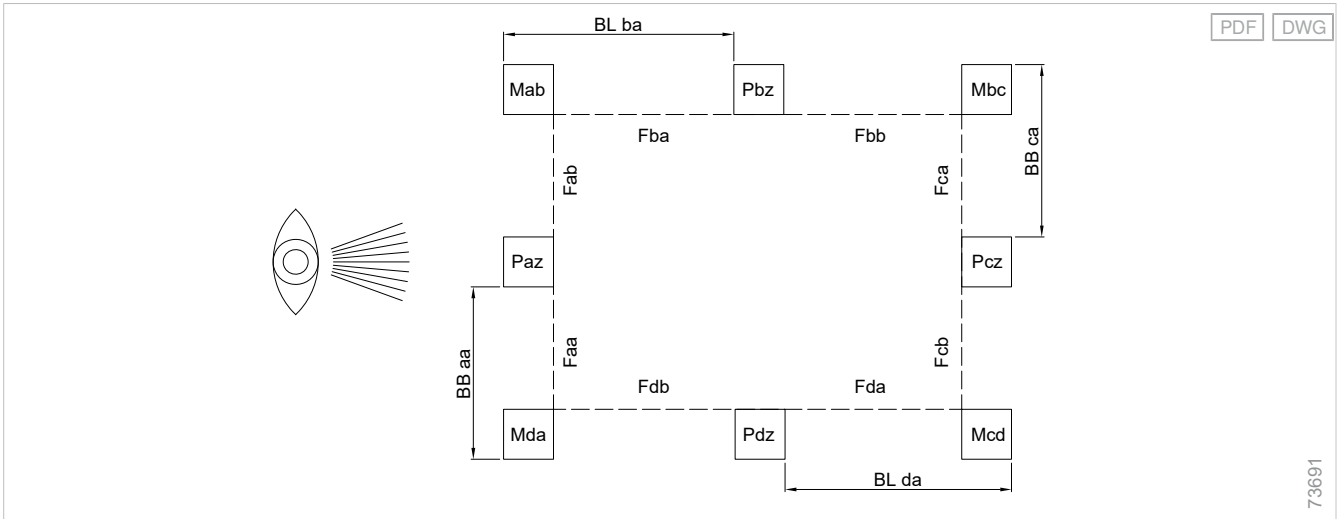

- | | | | |
|---|-------------------------------------------------|----|--------------|
| P | Pole | z | Additional |
| F | Field | BB | Order width |
| M | Point of installation (pole or wall connection) | BL | Order length |

Planning

Slat roofs
Lamaxa

Glass roofs
Lamaxa

Fabric roofs
Lamaxa

Supplementary
accessories

Drive
variants

Standards

Additional pole - L50

Components

Pole

Pole - L50

Material	Aluminium, extruded
Surface	Powder-coated
Material, notes	one-piece
Width	110 mm
Height	110 mm

Installation options:

- Ground installation with frost-proof, on-site foundation.
- The grout for filling the clearance is not included in the scope of delivery when threaded rods are used.

Base plate

Base plate - L50

Material	Galvanised steel
Surface	Plain
Optional surface	Powder-coated
Width	200 mm
Height	200 mm

Reinforced corner base plate - L50 View

Material	Galvanised steel
Surface	Plain
Optional surface	Powder-coated
Width	375 mm
Height	375 mm

Notes

Awnings with easyZIP guidance in combination with additional pole:

- Maximum 6 units per slat roof

LED lighting is not possible on an additional pole.

Positioning:

- The additional pole has a minimum offset dimension of 200 mm.
- An additional pole can be positioned for each field.
- L50 View: The additional poles can only be used in field a and field c.

Mounting examples

Additional pole - L50

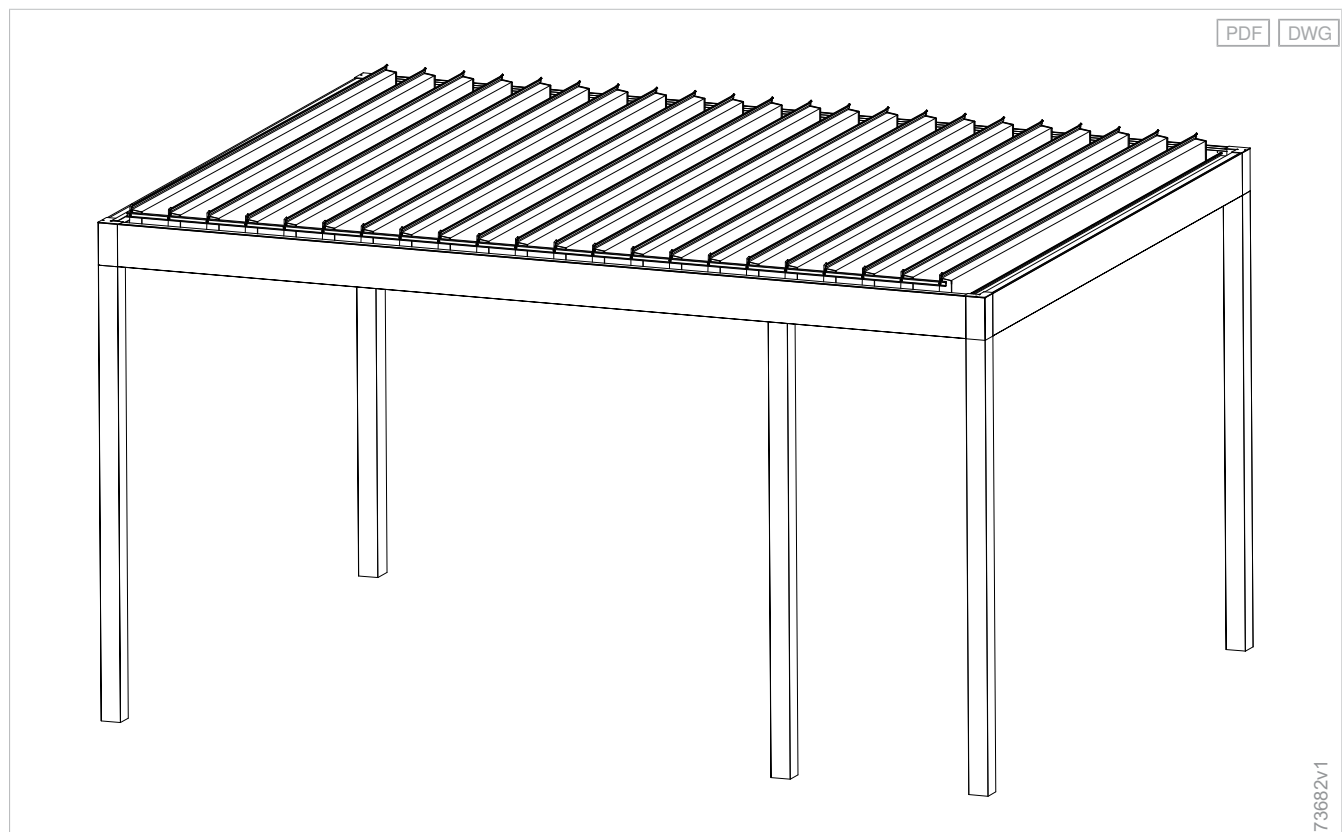

Top view of fields and poles - L50/L50 Tex/L60/L70

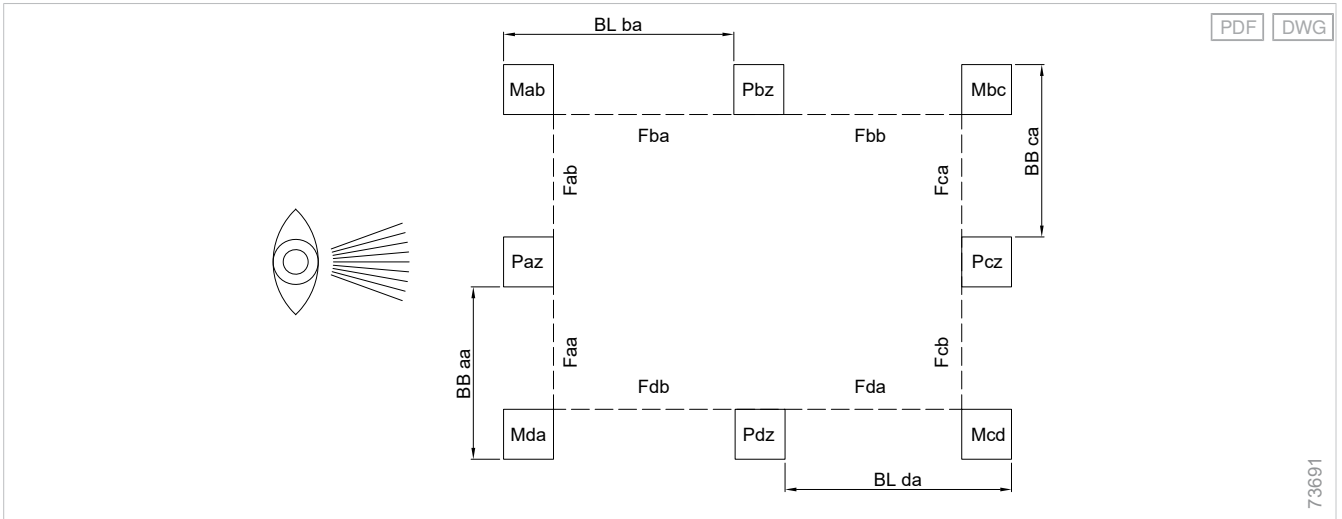

PDF DWG

73691

Planning

Slat roofs
Lamaxa

- | | | | |
|---|-------------------------------------------------|----|--------------|
| P | Pole | z | Additional |
| F | Field | BB | Order width |
| M | Point of installation (pole or wall connection) | BL | Order length |

Top view of fields and poles - L50 View

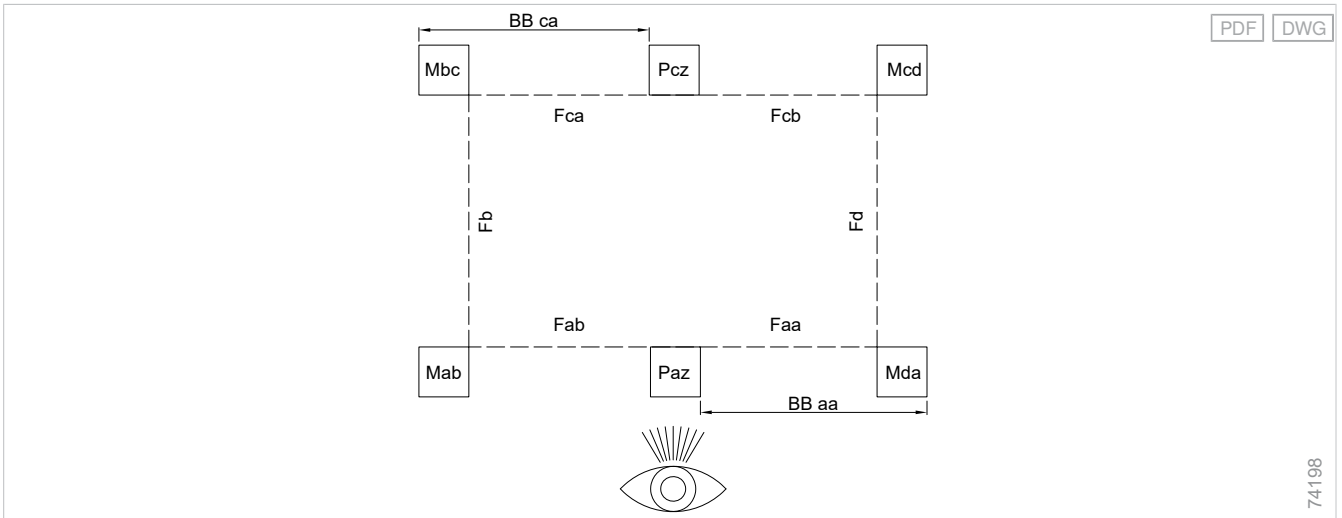

PDF DWG

74198

Glass roofs
Lamaxa

Fabric roofs
Lamaxa

- | | | | |
|---|-------------------------------------------------|----|-------------|
| P | Pole | z | Additional |
| F | Field | BB | Order width |
| M | Point of installation (pole or wall connection) | | |

Supplementary
accessories

Drive
variants

Standards



Supplementary accessories

Offset pole

Sheltered

Sun shading and weather protection of adjacent areas: The area under the slat roof as well as areas adjacent to it are shaded from direct sunlight or protected from the weather.

Offset

Spatial design freedom: Flexibly positioned, the construction appears less cubic but remains structurally stable.

Easily positionable

Takes structural particularities into account: A foundation is necessary to fix the pole. The pole can be flexibly positioned along the long crossbeam side in accordance with the substructure and the desired placement.



Can be used for:

- Lamaxa L60
- Lamaxa L70
- Lamaxa L50/L50 Tex

Product characteristics

- Realisation of a roof overhang
- More flexible positioning of the pole creates more open space

Offset pole - L60/L70

Components

Pole

Pole - L60/L70

Material	Aluminium, extruded
Surface	Powder-coated
Width	170 mm
Height	170 mm

Installation options:

Ground installation with frost-proof, on-site foundation.

The grout for filling the clearance is not included in the scope of delivery when threaded rods are used.

Floor recess and separation cut:

For a floor recess, we recommend the use of a separation cut in the inspection parts to allow for inspection without dismantling the floor. If the floor recess does not have a separation cut, the easyZIP guidance inlays and the integrated LED strips reach the bottom edge of the pole profile.

Base plate

Base plate - corner installation L60/L70

Material	Galvanised steel
Surface	Plain
Optional surface	Powder-coated
Width	300 mm
Height	300 mm

Notes

- **The offset is max. 1,200 mm or max. 1/3 of the order length.**
- **The poles can be offset along crossbeams b and d.**
- **L60: One pole (b and d) can be offset for each field.**
- **L70: The poles Mbc and Mcd can be offset. However, Mab and Mda cannot be offset.**
- **L60/L70: The centre poles cannot be offset.**
- **For offset pole installation and inspection access, a minimum distance of 300 mm is required between the offset pole and the facade.**
- Minimum offset dimension: 250 mm.
- The on-site connecting line can be connected to the adjacent crossbeam via the offset pole.
- It is possible to install the integrated awning with easyZIP guidance between the corner pole and the offset pole. The installation of the crossbeam-inspection covers is carried out in two parts.
- It is not possible to retrofit an integrated awning with easyZIP guidance in an offset pole field.
- It is possible to integrate LED lighting into the pole between the corner pole and the offset poles.
- It is possible to integrate an outward or downward drainage point into the offset pole.
- ZIP systems and LED lighting are not possible between two offset poles.
- Only corner base plate possible.

Mounting examples

L60/L70, offset pole

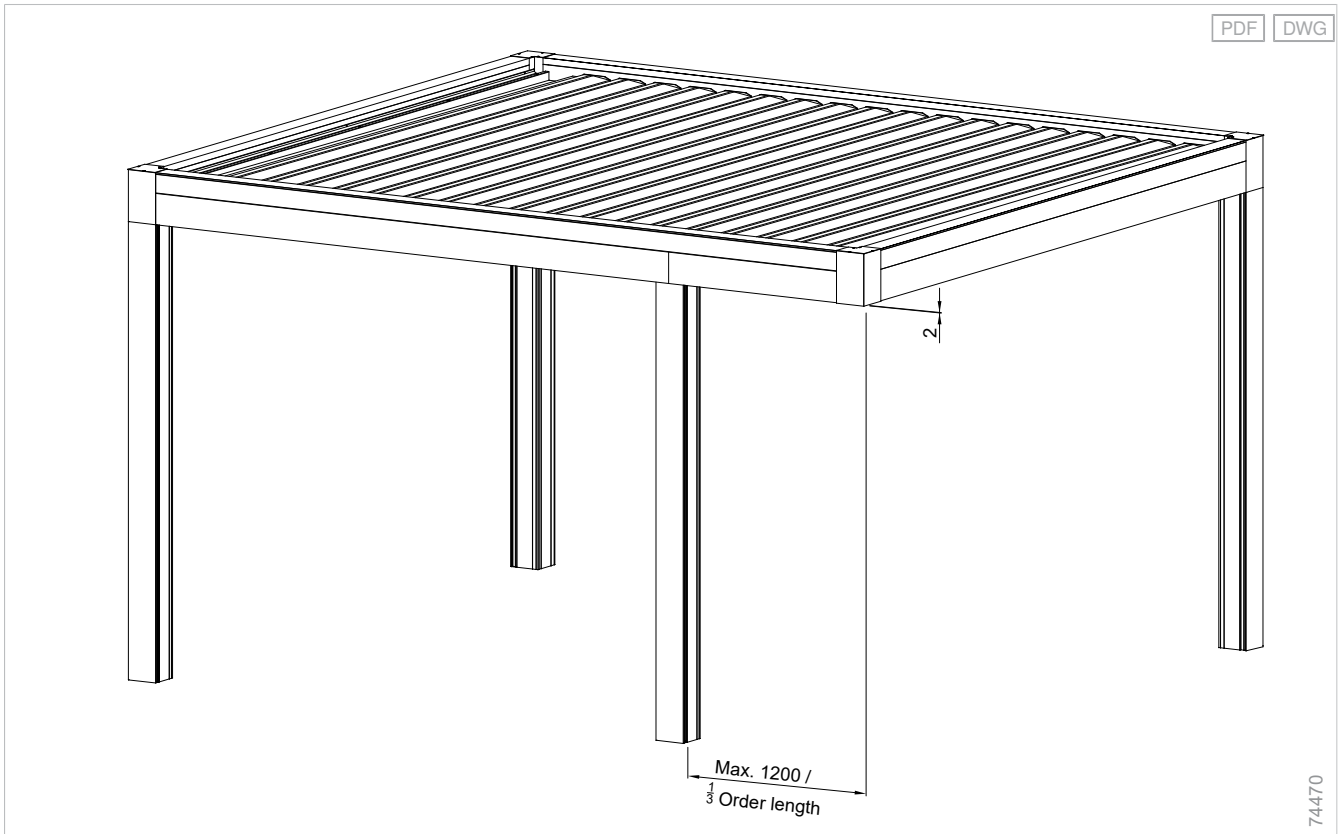

Offset pole - L50/L50 Tex

Components

Pole

Pole - L50

Material	Aluminium, extruded
Surface	Powder-coated
Material, notes	one-piece
Width	110 mm
Height	110 mm

Installation options:

- Ground installation with frost-proof, on-site foundation.
- The grout for filling the clearance is not included in the scope of delivery when threaded rods are used.

Base plate

Base plate - L50

Material	Galvanised steel
Surface	Plain
Optional surface	Powder-coated
Width	200 mm
Height	200 mm

Notes

- **The offset is max. 1,200 mm or max. 1/3 of the order length.**
- **The poles can be offset along crossbeams b and d.**
- **One pole (b and d) can be offset for each field.**
- Minimum offset dimension: 200 mm.
- The on-site connecting line cannot be connected to the adjacent crossbeam via the offset pole.
- It is possible to install the awning with easyZIP guidance between the corner pole and the offset pole.
- It is not possible to retrofit an awning with easyZIP guidance in an offset pole field.
- LED lighting on the offset pole is not possible.
- It is not possible to integrate a drainage point into the offset pole.
- With a free-standing slat roof, the connecting line pole cannot be offset.

Mounting examples

Offset pole - L50

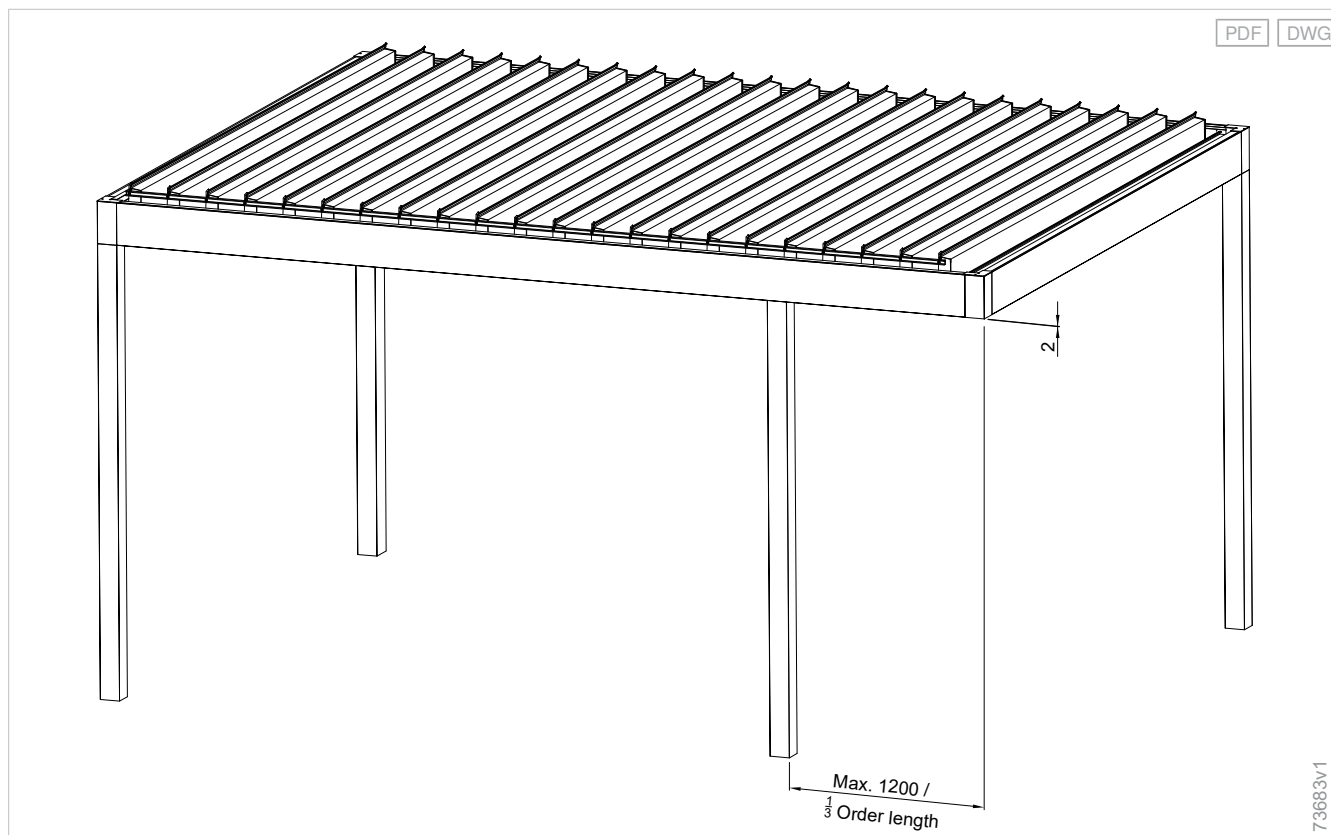



Supplementary accessories

Power socket

Expanded

Added value for Lamaxa: The addition of a power socket transforms the slat roof into a multifunctional outdoor working, dining or entertainment area.

Comfortable

Easy to connect: The power socket is positioned in the pole and is therefore easily accessible for devices such as laptops, fridges or music systems.

Customisable

For a harmonious colour match with the poles: The power socket is available in three different colours.

Can be used for:

- Perea P70
- Perea P60
- Lamaxa L70
- Lamaxa L60
- Lamaxa L50
- Lamaxa L50 View
- Lamaxa L50 Tex



Product characteristics

- An outdoor power socket guarantees a reliable power supply below the Lamaxa
- Simple positioning in the pole

Product characteristics

Material	Aluminium
Material colour	Anthracite, White, Aluminium colour

Product characteristics

Model F safety contact power socket with hinged cover

Position:

- Corner pole, additional and/or offset pole
- Inside or outside of the pole
- No power socket is possible in a drainage pole
- **Height 650 mm from base plate bottom edge (other heights upon request)**

Notes

A corresponding drilled hole can be preinstalled **for alternative plug types**.

Power socket in combination with radiant heater: The power socket can be combined with a maximum of one radiant heater! A separate connecting line is required if more than one radiant heater is installed.

Power socket in combination with drainage: Not possible in same pole.

Power socket in combination with sash frame: A power socket cannot be installed on the same side of the pole as the sash frame.

Attention: There must be a horizontal distance of at least 600 mm from a power socket to water (e.g. pool) in accordance with DIN VDE 0100 Section 701.

Connecting line is not included in the scope of delivery. It must be provided on site or ordered separately.

Dimension determination

Details

Power socket with hinged cover

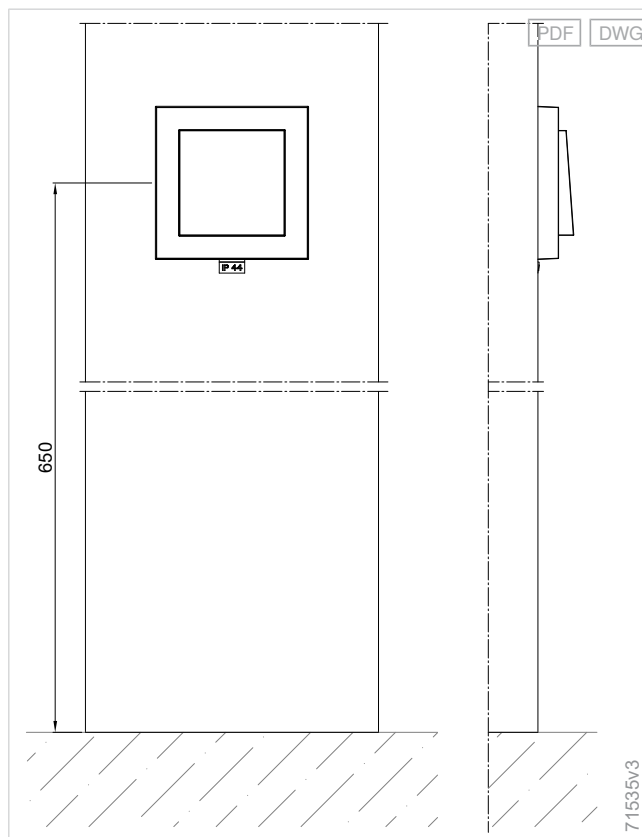

Planning

Slat roofs
Lamaxa

Glass roofs
Lamaxa

Fabric roofs
Lamaxa

Supplementary
accessories

Drive
variants

Standards



Supplementary accessories

Protection profile

Protects

Optimal closure in dust and rain: The protective profile reliably covers the transition from crossbeam to slat.

Permanent

Reliable connection: Spring hinges hold the protective profile in place when opening and closing the slats.

Suitable for retrofitting

Useful addition: The protective profile can be retrofitted to existing Lamaxa L50 slat roofs.

Can be used for:

- Lamaxa L60
- Lamaxa L60 Line
- Lamaxa L50
- Lamaxa L50 Line/star system



Product characteristics

- Optimum weather protection
- Clean finish thanks to neat closure between slats and crossbeam

Product characteristics

Material	Aluminium
Surface	Powder-coated

Product characteristics

The optional protection profile is installed on the inside of the two crossbeams and above the rain gutter. The protective profile is only available for the long crossbeam sides b and d.

The use of spring hinges ensures permanent contact both when opening and closing the slats. This optimal closure of the profile at the slats offers perfect protection against the **weather (dust and rain)**.

The protective profile is coated in the unit colour and can be retrofitted to existing Lamaxa L50 slats.

Dimension determination

Protection profile order length= order length

Radiant heater in combination with protection profile: The radiant heater cannot be combined with the protection profile.

Details

Protection profile - slats closed

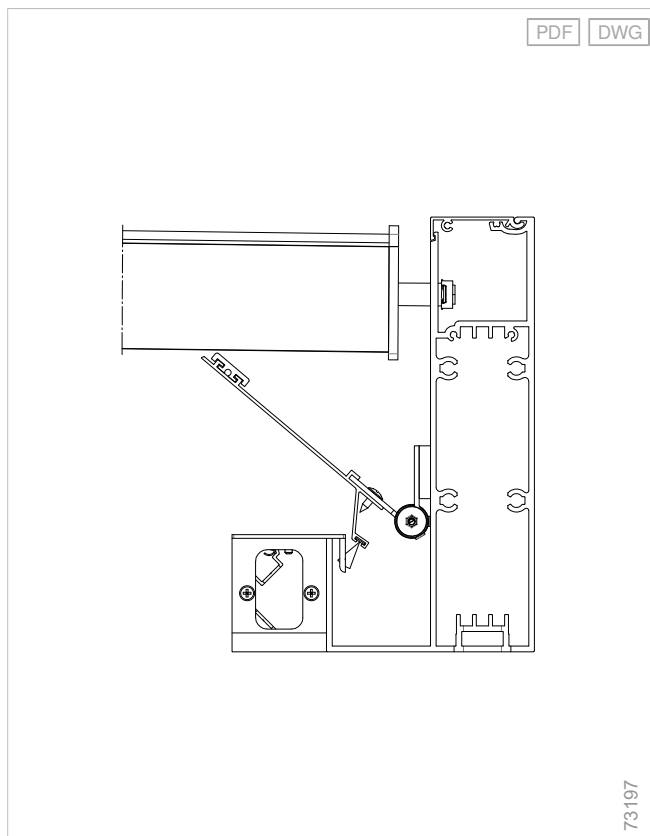

Protection profile - slats opened

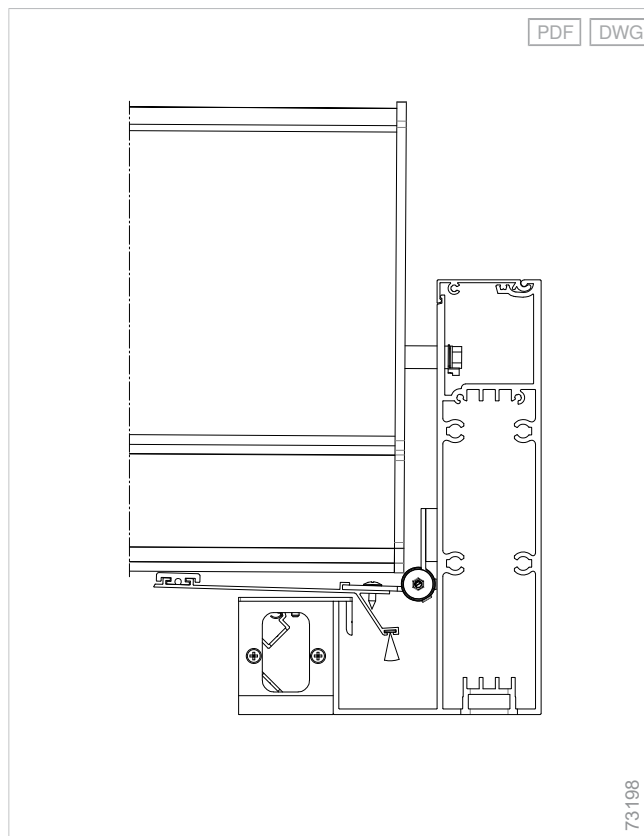

L60, protection profile, slats closed

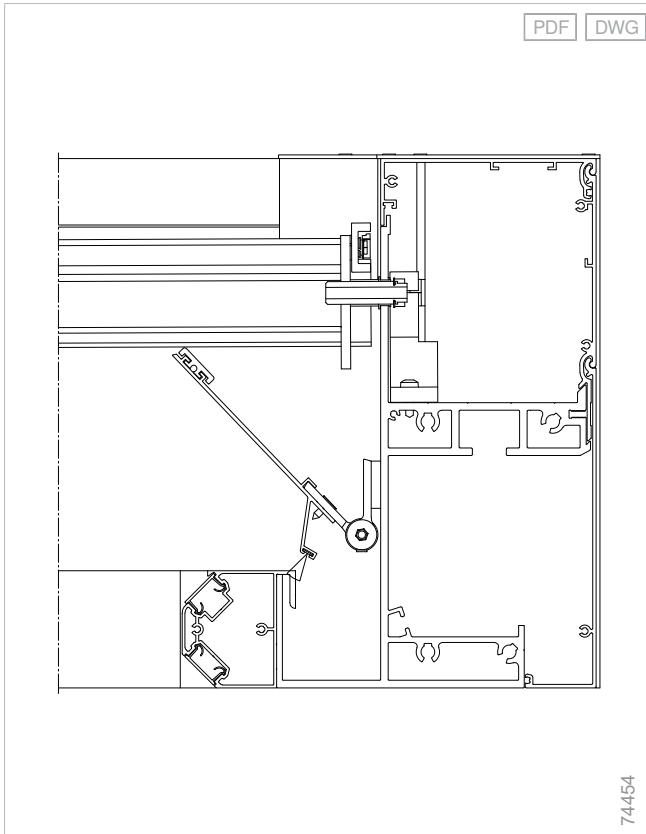

L60, protection profile, slats opened

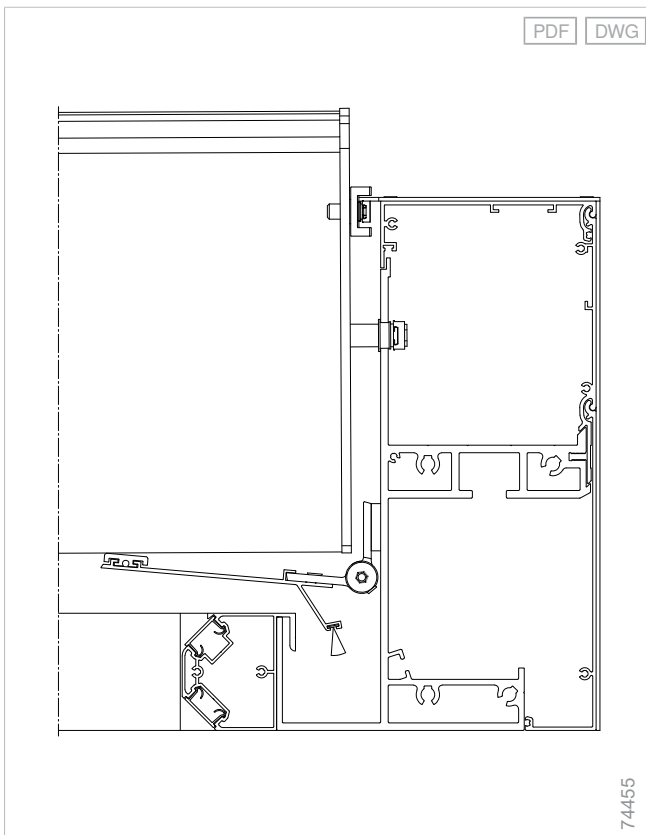

Contents

Drive variants

Motor.....	202
Standard motors, radio.....	203
WMS-LP (WMS).....	204
Manual operation.....	205
Manual operation - sliding glass elements SL20e.....	205
Handle shell.....	205

Planning

Slat roofs
Lamaxa

Glass roofs
Lamaxa

Fabric roofs
Lamaxa

Supplementary
accessories

Drive
variants

Standards



Drive variants

Motor

Innovative drives from leading suppliers

All drive solutions meet the highest quality standards: They are matched to the various WAREMA sun shading products.

Setting high standards for quality and functional performance

WAREMA oversees the development of new drives – from the conceptual design through to market launch.

Convenient installation and commissioning

Simple and guided commissioning with the WAREMA Smart programming cable.

Standard motors, radio

Technologies at a glance

Drives with mechanical limit switch-off

- Proven track record
- Reliable and precise
- Intuitive setting

Drives with electronic limit switch-off

- Software/function matches the sun shading product specifically
- Comfortable adjustment of the motor limit positions with programming cable

Electronic special drive WM REA for awnings with secudrive®

- With responsive block detection
- In the case of a blockage, the drive can differentiate between wind load and a fixed obstacle and correspondingly reacts sensitively to the situation.
- Extended awning protection, even with installation situations exposed to wind

EWFS radio motor

- Based on our unidirectional EWFS radio system with a transmission frequency of 433.92 MHz
- Comprehensive range of functions, e.g. teachable comfort position
- Combinable with comprehensive control components such as hand-held transmitters and weather stations

WMS Radio motor

- Based on our bidirectional WMS radio system with a transmission frequency of 2.4 GHz
- Maximum safety by means of an encrypted radio network
- Accurate moving to intermediate positions
- Exact position feedback
- Can also be operated via smartphone with WAREMA WebControl
- **Our highlight: On request, we can program your order with WMS radio motors for the delivered hand-held transmitter ex works, our service – your installation advantage!**

Electronic special drive MM for valance roller blinds in patio awnings

- Drop profile of the valance roller blind always retracts to be flush with the front rail
- With fabric stretching adjustment, readjustment of the motor limit position is omitted!

WMS-LP (WMS)

Description:

- Position switch-off bottom
- Position switch-off top
- Block detection
- Comfort position (intermediate position)
- Setting motor limit positions with WMS smart programming cable, WMS Central transmitter or WMS studio pro
- Bidirectional radio technology
- Position feedback via WMS radio control
- Accurate positioning using WMS radio control
- Intelligent routing function



Frequency	50 Hz
Transmission frequency	2,4 GHz
Degree of protection	IP 44
Motor construction type	Tubular motor
Motor operating type	Radio
Rated voltage	230 V AC
Type of limit switch-off	Electronic
Minimum run time	4 min
Torque	30 Nm
Speed	17 U/min
Nominal current	0,9 A
Rated power consumption	210 W
Plug-in connector	STAS 3
Overheat protection	Yes
Idle losses in standby	Yes
Operating temperature	-10 - 40 °C
Operating temperature, temporary	-20 - 80 °C
Motor lines	- H05RR-F 4 G 0.75 mm ² bk, type WAREMA
Test/programming cable	- WAREMA Smart programming cable

Wiring diagram STAS 3/STAK 3

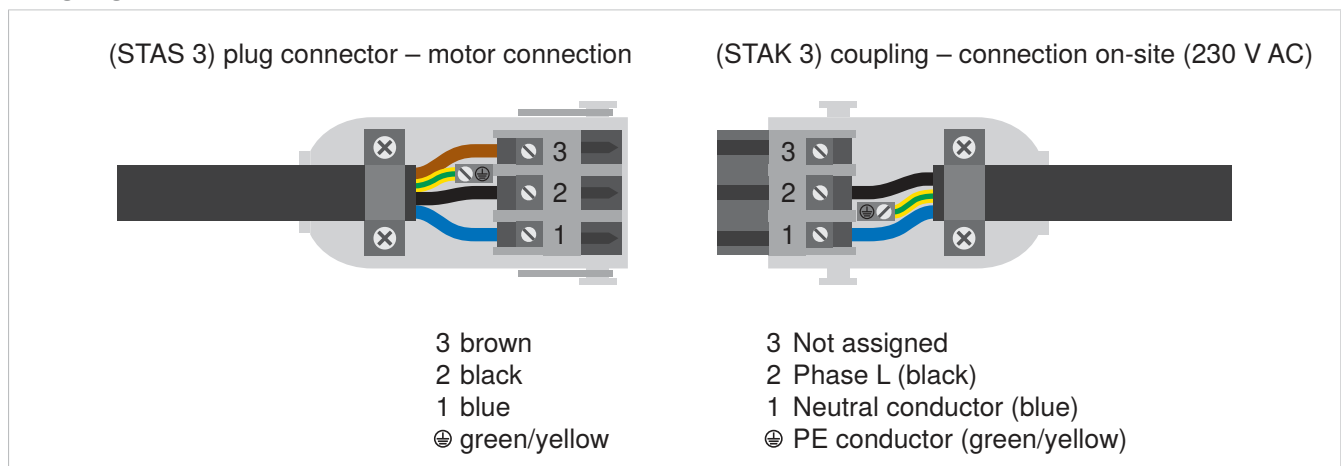

Manual operation

Manual operation - sliding glass elements SL20e

- Manual extension of the first wing.
- The other wings are pulled along by a carrier function.
- For four and six wings, there are 2 packages with one handle shell in each

Handle shell

Material	Stainless steel
Diameter	65 mm

Handle shell position: 1050 mm from the bottom edge of the running rail

Number: For four or six wings, there are 2 packages with one handle shell in each



Contents

Standards

General information.....208

Planning

Slat roofs
Lamaxa

Glass roofs
Lamaxa

Fabric roofs
Lamaxa

Supplementary
accessories

Drive
variants

Standards

General information

DIN ISO 9001

The certification according to ISO 9001 is an award that emphasises the high quality level of WAREMA sun shading technology. The requirement covers the entire manufacturing process from design and development to production and through to installation and service.

CE mark

Motorised external and internal sun shading systems are governed by Machinery Directive 2006/42/EC. An EC Declaration of Conformity is available for these products. External sun shading systems, as well as insect screen roller blinds, regardless of the type of drive, are subject to the Construction Products Regulation (EU)/2011. Declarations of performance are available for these products for the mandated property: wind resistance when extended.

All products governed by the Machinery Directive and/or the Construction Products Regulation are provided with a CE-mark.

Manually operated internal sun shading systems are not governed by either of these two directives or regulations and must not, therefore, be provided with a CE-mark. External or internal sun shading systems conform to the relevant standard, which sets out the details therein:

DIN EN 13659, DIN EN 13561 or DIN EN 13120.

Exceptions - the following products are not provided with a CE-mark: sun sails, patio side screens, insect screen products such as fixed frames, swivel doors, etc. - these products are either not mentioned in the harmonised standards or no testing procedure is defined.

230 V lines

All 230 V lines fulfil Euro class Fca. Special lines are to be requested if necessary.

Corrosion

WAREMA products achieve the corrosion classes described in the relevant standard. However, under extreme conditions (e.g. close to the coast), some corrosion of exposed stainless steel, chrome-plated or zinc-coated components may occur.

Sound insulation in building construction

Currently, no recognised testing method for power-operated closures/awnings exists to determine the emissions in accordance with "DIN 4109-1:2018 Sound insulation in building construction". Because of this, it is not possible to provide the planner with concrete values for the respective sun shading system that they can use to determine the occurring immission in the room requiring insulation in advance with a transfer function.

ITRS e. V. shall provide a leaflet for sun shading systems in combination with sound insulation in building construction as support up until a recognised testing procedure exists.

Note on drawing contents

The greyed-out sections of the illustration represent interfaces to general trades which, on the whole, must be planned and performed independently and on-site. WAREMA does not provide services for the greyed-out interfaces and assumes no liability for them.



The leaflet for sun shading systems in combination with sound insulation in building construction can be found on the IVRSA homepage in the "Technical documents" section.

Planning

Slat roofs
Lamaxa

Glass roofs
Lamaxa

Fabric roofs
Lamaxa

Supplementary
accessories

Drive
variants

Standards

WAREMA

Contacts

WAREMA Customer support

Technical support, provision of documents and forms,
questions about existing orders and quotation requests

Tel. +49 9391 20-8060
hallo@warema.de

Orders

my.warema.com
dachsysteme@warema.de

Maintenance

Spare parts ordering, repair work performed at the factory,
telephone support after product delivery, customer service
deployment on-site

Tel. +49 9391 20-9380
service@warema.de

myWAREMA

Tel. +49 9391 20-8080
my@warema.com

WAREMA Renkhoff SE

Hans-Wilhelm-Renkhoff-Straße 2
97828 Marktheidenfeld • Germany
Postfach 1355 • 97822 Marktheidenfeld
Tel. +49 9391 20-0
info@warema.de
www.warema.de

WAREMA International GmbH

Hans-Wilhelm-Renkhoff-Straße 2
97828 Marktheidenfeld • Germany
Postfach 1355 • 97822 Marktheidenfeld
Tel. +49 9391 20-0
info@warema.com
www.warema.com

WAREMA Austria GmbH

Zaunweg 6
5071 Wals bei Salzburg • Austria
Tel. +43 662 853015-0
info@warema.at
www.warema.at

WAREMA France SARL

96, Avenue du Général de Gaulle
92250 La Garenne Colombes • France
Tel. +33 1 556609-40
info@warema.fr
www.warema.fr

WAREMA Benelux B.V.

Schepenlaan 3
6002 EE Weert • Netherlands
Tel. +31 495 8701-50
info@warema.nl
www.warema.nl

WAREMA Schweiz GmbH

Stationsstrasse 90
6023 Rothenburg • Switzerland
Tel. +41 41 553 63-00
info@warema.ch
www.warema.ch



2024

Experience our showrooms:

www.warema.com/experience

WAREMA Renkhoff SE

Hans-Wilhelm-Renkhoff-Straße 2
97828 Marktheidenfeld • Germany

Find Your Contact:

www.warema.com/country

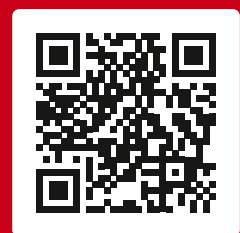

2052819/04.2024_enINT